

Mitsubishi Electric Programmable Controller Upgrade Tool

Base Adapter

Model

ERNT-2JR38KB

ERNT-2JR36KB38ZB

ERNT-2JR34KB

ERNT-2JR318KB

ERNT-2JR316KB36ZB

ERNT-2JR314KB

ERNT-2JR34ZB



User's Manual

50D-FG0638-A(2205)

MITSUBISHI ELECTRIC ENGINEERING COMPANY LIMITED
 HEAD OFFICE: Huiic KUDAN BLDG.1-13-5, KUDANKITA CHIYODA-KU, TOKYO 102-0073, JAPAN
 NAGOYA ENGINEERING OFFICE: 139 SHIMOYASHIKICHO-SHIMOYASHIKI, KASUGAI, AICHI 486-0906, JAPAN

SAFETY PRECAUTIONS

(Always read these precautions prior to use.)

Before using this product, please read this manual carefully and pay full attention to safety to ensure that the product is used correctly.

The precautions presented in this manual are concerned with this product only. For Programmable Controller system safety precautions, refer to the following manuals.

- MELSEC-Q series: QCPU User's Manual (SH-080483ENG)
- MELSEC iQ-R series: Safety Guidelines (IB-0800525E)

In this manual, the safety precautions are ranked as "WARNING" and "CAUTION."

| | |
|--|---|
| | Indicates that incorrect handling may cause hazardous conditions, resulting in death or severe injury. |
| | Indicates that incorrect handling may cause hazardous conditions, resulting in medium or minor injury and/or property damage. |

Note that failure to observe the CAUTION level instructions may lead to a serious consequence according to the circumstances. Always follow the precautions of both levels because they are important to personal safety.

Please keep this manual in an easy-to-access location for future reference, and be sure to provide the manual to the end user.

[Installation Precautions]

WARNING

- Be sure to shut off all phases of the external power supply before performing installation work. Failure to do so could result in electric shock or product damage.

CAUTION

- Use the base adapter in the environmental conditions that are specified in the general specification in the following manuals. Failure to do so could lead to electric shock, fire, malfunction or product failure or deterioration.
 - MELSEC-Q series: QCPU User's Manual (SH-080483ENG)
 - MELSEC iQ-R series: Safety Guidelines (IB-0800525E)

- Fully secure the base adapter, Programmable Controller base unit (MELSEC-Q Series, MELSEC iQ-R Series), and conversion adapter anchor base using the installation screws, and securely tighten the screws within the specified torque range. Failure to do so could cause the product to fall, resulting in damage.

Excessively tightened the screws may cause damage to the screws, base adapter, and target sequencer base unit (MELSEC-Q series, MELSEC iQ-R series) and cause them to fall.

[Startup and Maintenance Precautions]

WARNING

- Be sure to shut off all phases of the external power supply before cleaning and retightening the installation screws. Failure to do so could lead to electric shock. Excessively tightened screws could result in damage, base adapter, and target sequencer base unit (MELSEC-Q series, MELSEC iQ-R series) base unit, causing the product to fall, a short circuit or product malfunction.

CAUTION

- Do not drop the base adapter or subject it to strong It may cause damage.

[Disposal Precautions]

CAUTION

- When disposing of the product, treat it as industrial waste.

安全注意事项

(使用前请务必阅读)

使用本产品时, 请仔细阅读本手册, 并充分注意安全, 正确地使用产品。本手册中标注的注意事项仅记载了与本产品相关的内容。关于可编程控制器系统的安全注意事项, 请参照下面的说明手册。

- MELSEC-Q series: QCPU User's Manual (SH-080483ENG)
- MELSEC iQ-R series: Safety Guidelines (IB-0800525E)

在本●安全注意事项●中, 安全注意事项的等级分为「警告」和「注意」。

| | |
|--|----------------------------------|
| | 表示错误操作可能造成危险后果, 引起死亡或重伤事故。 |
| | 表示错误操作可能造成危险后果, 引起中度伤害, 轻伤及财产损失。 |

另外, 根据情况不同, 即使是注意中记载的事项, 也可能引发严重后果。不管哪个记载的都是非常重要的内容, 请务必遵守。请妥善保管本手册, 以便需要时取阅, 并请将该手册交给最终用户。

【安装注意事项】

警告

- 必须将外部供应电源全相断开后再进行安装作业等。如果未全相断开, 可能会导致触电或产品损坏。

注意

- 基板适配器被要求在下面手册里所记载的一般规格环境下使用。如果在一般规格范围以外的环境中使用, 可能导致触电、火灾、误动作、产品的损坏或劣化。
 - MELSEC-Q系列: QCPU用户手册 (SH-080501CHN)
 - MELSEC iQ-R系列: Safety Guidelines (IB-0800525E)
- 基板适配器及所使用的可编程控制器模块基板 (MELSEC-Q 系列, MELSEC iQ-R 系列) 应通过安装螺钉切实加以固定, 安装螺钉应在规定的扭矩范围内切实地拧紧。如果螺钉拧得过松, 有可能因掉落而导致基板适配器及 MELSEC-Q 系列或者 MELSEC iQ-R 系列基板破损。如果螺钉拧得过紧, 有可能造成螺钉、基板适配器及所使用的可编程控制器模块列基板 (MELSEC-Q 系列, MELSEC iQ-R 系列) 破损, 从而导致掉落。

【启动和维护注意事项】

警告

- 在清洁模块或重新紧固安装螺钉时, 必须将系统使用的外部供应电源全部断开后 再进行操作。如果未全部断开, 有可能导致触电。如果螺钉拧得过松, 有可能导致掉落、短路或误动作。如果螺钉拧得过紧, 有可能会造成螺钉、基板适配器和所使用的可编程控制器模块列基本 (MELSEC-Q 系列, MELSEC iQ-R 系列) 模块破损, 从而导致掉落、短路或误动作。

注意

- 请勿使基板适配器掉落或受到强烈撞击。否则可能导致破损。

【废弃注意事项】

注意

- 废弃时请将本产品作为工业废弃物处理。

1. Overview

This manual describes the Mitsubishi Electric Programmable Controller Upgrade Tool base adapter (ERNT-2JR38KB, ERNT-2JR36KB38ZB, ERNT-2JR34KB, ERNT-2JR318KB, ERNT-2JR316KB36ZB, ERNT-2JR314KB, ERNT-2JR34ZB). The base adapter is a product that enables MELSEC-Q series (hereinafter called Q Series) or MELSEC iQ-R series (hereinafter called iQ-R Series) or JW series installation using the MELSEC-A series (hereinafter called A Series) installation holes. (Additional hole machining not required)

Once you have opened the packaging, verify that it contains the following products

| Product | Shape | Quantity |
|--------------|-------|----------|
| Base adapter | | 1 |
| This manual | - | 1 |

2. Product Specifications

| Base Adapter Model | Specifications | | | |
|--------------------|-------------------------------|----------------------------|-------------------------------|------------|
| | JW Series Compatible Module | Q Series Compatible Module | iQ-R Series Compatible Module | Weight (g) |
| ERNT-2JR38KB | JW-28KB JW-38KB | Q312B Q38B | R312B R310B-HT R38B | 845 |
| ERNT-2JR36KB38ZB | JW-26KB JW-36KB JW-38ZB | Q38B Q68B | R38B R68B | 705 |
| ERNT-2JR34KB | JW-24KB JW-34KB | Q35B | R35B | 470 |
| ERNT-2JR318KB | JW-318KB | Q38B | R38B | 775 |
| ERNT-2JR316KB36ZB | JW-316KB JW-36ZB | Q38B Q68B | R38B R68B | 655 |
| ERNT-2JR314KB | JW-314KB | Q35B | R35B | 500 |
| ERNT-2JR34ZB | JW-34ZB | Q65B Q55B | R65B | 570 |

3. Mounting and Installation

3.1 Handling Precautions

(1) Before attempting to install the Unit, make certain that the external power supply, used in the system, is shut off on all three phases. Failure to do so may result in electric shock or damage to the product.

(2) Fasten the Base Adapter and the Programmable Controller Base Unit (Q series, iQ-R series) securely with retaining screws, and tighten the screws by applying torque within specified limits. Loose screws can lead to the dropping of the Base Adapter or Q Series or iQ-R Series Base Unit, possibly causing breakage thereof. Excessive tightness of the screws can lead to breakage of the screws, Base Adapter or Programmable Controller Base Unit (Q Series, iQ-R Series), possibly causing the dropping.

(3) Do not drop the Base Adapter or do not give a strong impact to it. This will cause damage.

3.2 Installation Environment

Refer to the manual supplied with the Q Series or iQ-R Series module you use.

- Q series: QCPU User's Manual (SH-080483ENG)
- iQ-R series: Safety Guidelines (IB-0800525E)

4. Installation Dimensions

The base adapter installation holes (4 locations) have the same installation dimensions as those of the A series base unit. There is no need for additional screw hole machining on the control panel.

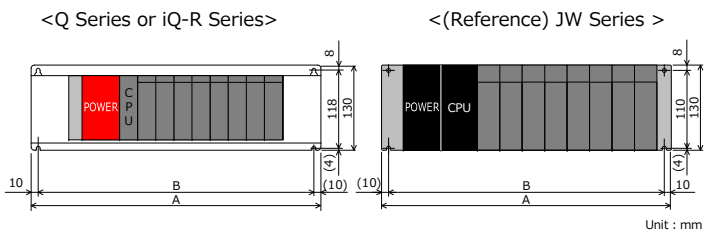

| Base Adapter Model | A | B | C | JW Series Compatible Module | a | b |
|--------------------|-------|-------|-----|-------------------------------|--------------|--------------|
| ERNT-2JR38KB | 442.5 | 421 | - | JW-28KB JW-38KB | 437 | 421 |
| ERNT-2JR36KB38ZB | 368 | 352 | - | JW-26KB JW-36KB JW-38ZB | 368 | 352 |
| ERNT-2JR34KB | 297 | 281 | - | JW-24KB JW-34KB | 297 | 281 |
| ERNT-2JR318KB | 403.5 | 387.5 | - | JW-318KB | 403.5 | 387.5 |
| ERNT-2JR316KB36ZB | 343.5 | 316.5 | 281 | JW-316KB JW-36ZB | 332.5 297 | 316.5 281 |
| ERNT-2JR314KB | 261.5 | 245.5 | - | JW-314KB | 261.5 | 245.5 |
| ERNT-2JR34ZB | 245.9 | 210 | - | JW-34ZB | 226 | 210 |

Precaution

Check the mounting position before mounting the base unit correctly. If it is installed in the wrong position, it may damage the conversion adapter or the unit.

5. Part Names and installation Method

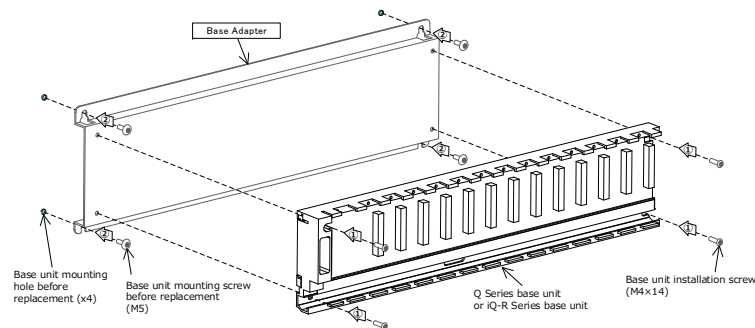

5.1 Installation Method

- Secure the IQ-R Series or Q Series base unit with the base unit installation screws (M4 x 14) supplied with the base adapter (4 locations)
- Fix the base adapter to the board with the base unit mounting screw before replacement (M5). (4 locations)

5.2 Tightening Torque

Tightening the module installation screws to the specified torque below. An inappropriate tightening torque could cause the product to fall or result in a short circuit, product failure or malfunction.

| Screw Location | Tightening Torque Range |
|-----------------------------------|-------------------------|
| Base unit installation screw (M4) | 1.39~1.89 N·m |
| Base unit mounting screw (M5) | 2.75~3.63 N·m |

6. Base Unit Installation Locations

(1) ERNT-2JR38KB

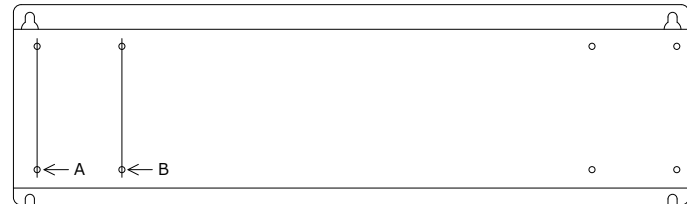

| Conversion Adapter Anchor Base | A | B |
|-----------------------------------|---|---|
| Base Unit | | |
| Q312B | ○ | - |
| R312B | | |
| Q38B | - | ○ |
| R38B | | |

(2) ERNT-2JR36KB38ZB

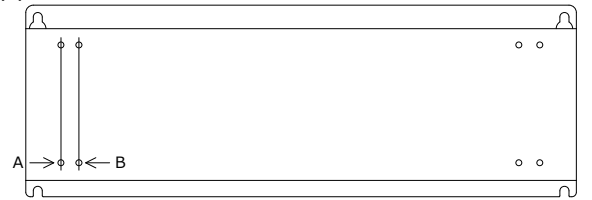

| Conversion Adapter Anchor Base | A | B |
|-----------------------------------|---|---|
| Base Unit | | |
| Q38B | - | ○ |
| Q68B | ○ | - |
| R38B | ○ | ○ |
| R68B | | |

(3) ERNT-2JR34KB

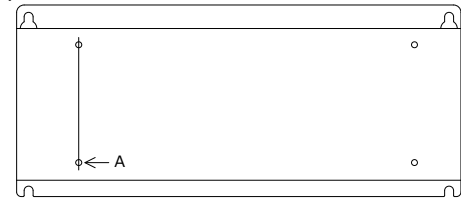

| Conversion Adapter Anchor Base | A |
|-----------------------------------|---|
| Base Unit | |
| Q35B | ○ |
| R35B | |

(4) ERNT-2JR318KB

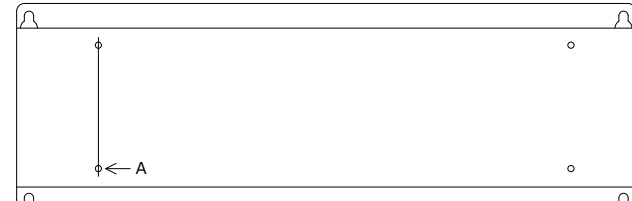

| Conversion Adapter Anchor Base | A |
|-----------------------------------|---|
| Base Unit | |
| Q38B | ○ |
| R38B | |

(5) ERNT-2JR316KB36ZB

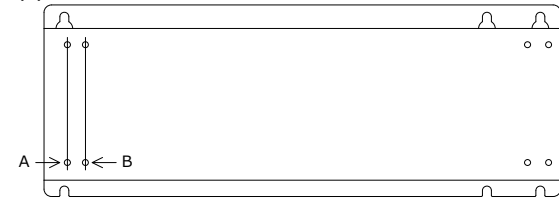

| Conversion Adapter Anchor Base | A | B |
|-----------------------------------|---|---|
| Base Unit | | |
| Q38B | - | ○ |
| Q68B | ○ | - |
| R38B | ○ | ○ |
| R68B | | |

(6) ERNT-2JR314KB

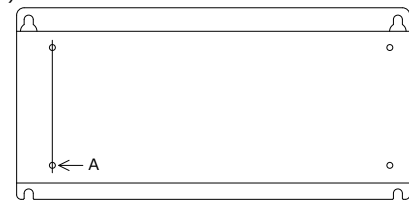

| Conversion Adapter Anchor Base | A |
|-----------------------------------|---|
| Base Unit | |
| Q35B | ○ |
| R35B | |

(7) ERNT-2JR34ZB

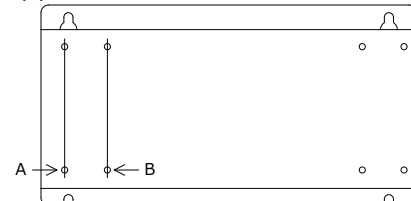

| Conversion Adapter Anchor Base | A | B |
|-----------------------------------|---|---|
| Base Unit | | |
| Q65B | ○ | - |
| R65B | | |
| Q55B | - | ○ |

7. External Dimensions

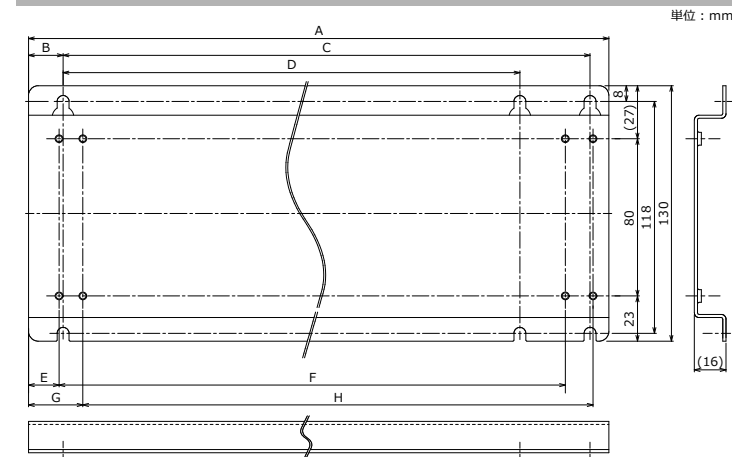

| Base Adapter Model | A | B | C | D | E | F | G | H |
|--------------------|-------|------|-------|-----|------|-------|------|-----|
| ERNT-2JR38KB | 442.5 | 10.8 | 421 | - | 15.5 | 419 | 71 | 308 |
| ERNT-2JR36KB38ZB | 368 | 8 | 352 | - | 23.5 | 306 | 35.5 | 308 |
| ERNT-2JR34KB | 297 | 8 | 281 | - | 41.5 | 224.4 | - | - |
| ERNT-2JR318KB | 403.5 | 8 | 387.5 | - | 53.3 | 308 | - | - |
| ERNT-2JR316KB36ZB | 343.5 | 13.5 | 316.5 | 281 | 15.5 | 306 | 27.5 | 308 |
| ERNT-2JR314KB | 261.5 | 8 | 245.5 | - | 23.8 | 224.4 | - | - |
| ERNT-2JR34ZB | 245.9 | 18 | 210 | - | 15.5 | 222.4 | 43.5 | 167 |

Duplication Prohibited

This manual may not be reproduced in any form, in part or in whole, without written permission from Mitsubishi Electric Engineering Company Limited.
©2022 MITSUBISHI ELECTRIC ENGINEERING COMPANY LIMITED ALL RIGHTS RESERVED

MELSEC and MELSEC IQ-R is a registered trademark of Mitsubishi Electric Corporation in Japan.
ERNT is a registered trademark of Mitsubishi Electric Engineering Company Limited in Japan.
All company and product names herein are either trademarks or registered trademarks of their respective owners.

Product Warranty Details

Please confirm the following product warranty details prior to product use.

Gratis Warranty Terms and Gratis Warranty Range

If any fault or defect (hereinafter referred to as "Failure") attributable to Mitsubishi Electric Engineering Company Limited (hereinafter referred to as "MEE") should occur within the gratis warranty period, MEE shall repair the product free of charge via the distributor from whom you made your purchase.

Gratis Warranty Period

The gratis warranty period of this product shall be one (1) year from the date of purchase or delivery to the designated place.

Note that after manufacture and shipment from MEE, the maximum distribution period shall be six (6) months, and the gratis warranty period after manufacturing shall be limited to eighteen (18) months.

In addition, the gratis warranty period for repaired products shall not exceed the gratis warranty period established prior to repair.

Gratis Warranty Range

The gratis warranty range shall be limited to normal use based on the usage conditions, methods and environment, etc., defined by the terms and precautions, etc., given in the instruction manual, user's manual and caution labels on the product.

Warranty Period after Discontinuation of Production

- MEE shall offer product repair services (fee applied) for seven (7) years after production of the product has been discontinued. Discontinuation of production shall be reported via distributors.
- Product supply (including spare parts) is not possible after production has been discontinued.

Exclusion of Opportunity Loss and Secondary Loss from Warranty Liability

Regardless of the gratis warranty period, MEE shall not be liable for compensation for damages arising from causes not attributable to MEE, opportunity losses or lost profits incurred by the user due to Failures of MEE products, damages or secondary damages arising from special circumstances, whether foreseen or unforeseen by MEE, compensation for accidents, compensation for damages to products other than MEE products, or compensation for other work carried out by the user.

Changes in Product Specifications

The specifications given in the catalogs, manuals and technical documents are subject to change without notice.

This document is a new publication, effective May 2022. Specifications are subject to change without notice.