

# Analog Signal Conversion Module (Output type) FA-ATB8YTB,FA1-AT1B4Y1TE,FA1-AT1B4Y1TB, FA-ATS\*M1Y\*\*\*\*\*, FA-ATFTMXY, FA-Q6TCA

## User's Manual

Thank you for purchasing the FA Goods products.

Before using the products, please read this manual and the relevant manuals carefully to handle the products correctly.

**mitsubishi electric engineering company limited**

### SAFETY PRECAUTIONS

(Read these precautions before using the FA Goods products.)

Before using the products, please read this manual and the relevant manuals carefully, and pay full attention to safety to handle the products correctly.

The precautions given in this manual are concerned with time and wire saving device only.

For the safety precautions of the programmable controller system, refer to the user's manual for the programmable controller used.

If the equipment is used in a manner not specified by the manufacturer, the protection provided by the equipment may be impaired.

In this manual, the safety precautions are classified into two levels: "⚠️WARNING" and "⚠️CAUTION".

 **WARNING**

Indicates that incorrect handling may cause hazardous conditions, resulting in death or severe injury.

 **CAUTION**

Indicates that incorrect handling may cause hazardous conditions, resulting in minor or moderate injury or property damage.

Under some circumstances, failure to observe the precautions given under "⚠️CAUTION" may lead to serious consequences.

Observe the precautions of both levels because they are important for personal and system safety.

## [Design Precautions]



### WARNING

- Configure safety circuits externally to ensure that the entire system operates safely even when a fault occurs in the external power supply, the programmable controller, or the products. Failure to do so may result in an accident due to an incorrect output or malfunction.
  - (1) Emergency stop circuits, protection circuits, and protective interlock circuits for conflicting operations (such as forward/reverse rotations or upper/lower limit positioning) must be configured externally.
  - (2) Outputs may remain on or off due to a failure of a component such as a relay, transistor, and triac used for digital signal converter outputs. Configure an external circuit for monitoring output signals that could cause a serious accident.
- In an output circuit for digital signal converter outputs, when a load current exceeding the rated current or an overcurrent caused by a load short-circuit flows for a long time, it may cause smoke and fire. To prevent this, configure an external safety circuit, such as a fuse.
- Configure a circuit so that the programmable controller is turned on first and then the external power supply. If the external power supply is turned on first, an accident may occur due to an incorrect output or malfunction.

## [Design Precautions]



### CAUTION

- Do not install the control lines or communication cables together with the main circuit lines or power cables. Keep a distance of 100mm (3.94 inches) or more between them. Failure to do so may result in malfunction or failure due to noise.
- When using a terminal block conversion module for a high-speed counter module, do not install the control lines or communication cables together with the main circuit lines or power cables. Keep a distance of 150mm (5.91 inches) or more between them. Failure to do so may result in malfunction or failure due to noise.
- Keep a distance of 100mm (3.94 inches) or more between a thermocouple or RTD (Resistance Temperature Detector) and the main circuit line or AC control lines. Also, keep the thermocouple or RTD away from a circuit that includes harmonics, such as a high-voltage circuit and a load circuit of an inverter. If not, the thermocouple or RTD is more likely to be affected by noise, surges, and induction.
- At power-on or power-off, a voltage may occur or a current may flow between output terminals for a moment. To use an analog signal converter or analog terminal block conversion module, start the control after analog outputs become stable.
- Do not place an analog signal converter or analog terminal block conversion module near a device that generates magnetic noise.
- When a device such as a lamp, heater, or solenoid valve is controlled using a module for digital signal converter outputs, a large current (approximately 10 times greater than normal) may flow when the output is turned from off to on. Therefore, select a module for digital signal converter outputs that has a sufficient current rating.

## [Installation Precautions]



### WARNING

- Shut off the external power supply (all phases) used in the system before installation. Failure to do so may result in electric shock or damage to the products.

## [Installation Precautions]



### CAUTION

- Use products in an environment that meets the general specifications in this manual. Failure to do so may result in electric shock, fire, malfunction, or damage to or deterioration of the products.
- Securely fix the products with a DIN rail or screws. Incorrect installation may cause malfunction, failure, or drop of the module. When using the products in an environment of frequent vibrations, fix the products with screws.
- Tighten the screws within the specified torque range. Undertightening can cause drop of the screw, short circuit, or malfunction. Overtightening can damage the screw and/or products, resulting in drop, short circuit, or malfunction.
- Attach DIN rail stoppers on the right and left sides of the spring clamp conversion module (FA1-TESV\*\*) to fix the module securely.
- Shut off the external power supply (all phases) used in the system before mounting or removing the products. Failure to do so may result in damage to, malfunction of, or failure of the products.
- Do not directly touch any conductive parts and electronic components of the products. Failure to do so may cause malfunction or failure of the products.
- Install the products in the correct orientation if it is specified. Failure to do so may result in damage to or deterioration of the products.
- When drilling screw holes, be careful not to drop chips into the inside of the products or conductive parts. Such foreign matter can cause a fire, failure, or malfunction.
- When using modules for replacing digital signal converters or signal converters modules, use them correct combination. Incorrect combination may cause failure.
- Shut off the power supply before installing/removing a module for replacing digital signal converters. Failure to do so may cause failure or malfunction.
- Securely mount a module for replacing digital signal converters and signal conversion module on a digital signal converter and installation base. Failure to do so may cause damage to or drop of the products, or malfunction due to poor contact. Follow the correct procedure to install/remove them. Failure to do may cause damage to or drop of the products, or malfunction due to poor contact.
- When a module for digital signal converters or signal conversion module is mounted on a digital signal converter or installation base, hold the digital signal converter or installation base to transport them or install them to a panel. Holding the module for digital signal converters or signal conversion module may cause drop or failure of the digital signal converter or installation base.

## [Wiring Precautions]



### WARNING

- Shut off the external power supply (all phases) used in the system before wiring. Failure to do so may result in electric shock or damage to the products.
- After wiring, attach the included terminal cover to the products before turning them on for operation. Failure to do so may result in electric shock.
- Use copper conductors only a temperature rating of 75°C or more.

## [Wiring Precautions]



### CAUTION

- Use applicable solderless terminals and tighten them within the specified torque range. Failure to do so may cause failure, damage, or malfunction.
- Check the rated voltage and terminal layout before wiring to the products, and connect the cables correctly. Connecting a power supply with a different voltage rating or incorrect wiring may cause a fire or failure.
- Do not install the control lines or communication cables together with the main circuit lines or power cables. Keep a distance of 100mm or more between them. Failure to do so may result in malfunction due to noise.
- When using a terminal block conversion module for a high-speed counter module, do not install the control lines or communication cables together with the main circuit lines or power cables. Keep a distance of 150mm (5.91 inches) or more between them. Failure to do so may result in malfunction or failure due to noise.
- Keep a distance of 100mm (3.94 inches) or more between a thermocouple or RTD (Resistance Temperature Detector) and the main circuit line or AC control lines. Also, keep the thermocouple or RTD away from a circuit that includes harmonics, such as a high-voltage circuit and a load circuit of an inverter. If not, the thermocouple or RTD is more likely to be affected by noise, surges, and induction.
- Do not place an analog signal converter or analog terminal block conversion module near a device that generates magnetic noise.
- Place the cables in a duct or clamp them. If not, dangling cable may swing or inadvertently be pulled, resulting in damage to the products or cables or malfunction due to poor contact.
- Tighten the terminal screws within the specified torque range. Undertightening can cause short circuit, fire, or malfunction. Overtightening can damage the screw and/or products, resulting in drop, short circuit, or malfunction.
- Tighten the connector screws within the specified torque range. Undertightening can cause short circuit, fire, or malfunction. Overtightening can damage the screw and/or products, resulting in drop, short circuit, fire, or malfunction.
- Securely connect connectors to the products. Failure to do so may cause malfunction.
- When disconnecting a cable from the products, do not pull the cable by the cable part. For the cable with connector, hold the connector part of the cable. For the cable connected to the terminal block, loosen the terminal screw. Pulling the cable connected to the products may result in malfunction or damage to the products or cable.
- Check the interface type and correctly connect the cable. Incorrect wiring (connecting the cable to an incorrect interface) may cause failure of the products and external device.
- Prevent foreign matter such as dust or wire chips from entering the products. Such foreign matter can cause a fire, failure, or malfunction.
- The products must be installed in control panels. Connect the main power supply to the products in the control panel through a relay terminal block. Wiring and replacement of the products must be performed by qualified maintenance personnel with knowledge of protection against electric shock.
- When connecting the products with a programmable controller, check that the product configuration is correct. An incorrect configuration may cause failure or malfunction.
- Use the products with no force applied to their connectors. Applied force may cause failure or disconnection.
- Attach protective covers or signal conversion modules to unused connectors or empty slots of the products. Failure to do so may cause a fire, failure, or malfunction due to foreign matter.
- When using modules for replacing digital signal converters or signal conversion modules, use them in the correct combination. Incorrect combination may cause failure of a programmable controller, digital signal converter, installation base, or external device.
- Securely mount modules for replacing digital signal converters and signal conversion modules on a digital signal converter and installation base. Failure to do so may cause damage to or drop of the products, or malfunction due to poor contact. Follow the correct procedure to install/remove them. Failure to do so may cause damage to or drop of the products, or malfunction due to poor contact.
- Individually ground the FG terminal of the products with a ground resistance of 100 ohms or less. Failure to do so may result in electric shock or malfunction.

### [Startup and Maintenance Precautions]

#### **WARNING**

- Do not touch any terminal while power is on. Doing so will cause electric shock or malfunction.
- Shut off the external power supply (all phases) used in the system before cleaning the products or retightening the terminal screws, connector screws, or products fixing screws. Failure to do so may result in electric shock or cause failure or malfunction of the products. Undertightening can cause drop of the screw, short circuit, or malfunction. Overtightening can damage the screw and/or products, resulting in drop, short circuit, or malfunction.

### [Startup and Maintenance Precautions]

#### **CAUTION**

- Do not disassemble or modify the products. Doing so may cause failure, malfunction, injury, or a fire.
- Use any radio communication device such as a cellular phone or PHS (Personal Handy-phone System) more than 25cm away in all directions from the programmable controller and products. Failure to do so may cause malfunction.
- Shut off the external power supply (all phases) used in the system before mounting or removing the products. Failure to do so may cause failure or malfunction of or damage to the products.
- After the first use of the products, do not connect/remove the products and cables more than 50 times (IEC 61131-2 compliant). Exceeding the limit may cause malfunction.
- Startup and maintenance of a control panel must be performed by qualified maintenance personnel with knowledge of protection against electric shock. Lock the control panel so that only qualified maintenance personnel can operate it.
- Before handling the products, touch a conducting object such as a grounded metal to discharge the static electricity from the human body. Failure to do so may cause failure or malfunction of the products.
- The ESD susceptibility symbol shown below is placed on the products. This symbol products is susceptible static electricity passed. Before handling the connector, touch a conducting object such as a grounded metal to release the static electricity from your body. Failure to do so may cause the products to fail or malfunction. Do not touch the connector when the products is powered. Doing so may result in injury or cause the products to malfunction due to the static electricity in your body.



### [Disposal Precautions]

#### **CAUTION**

- When disposing of the products, treat them as industrial waste.

### [Transportation Precautions]

#### **CAUTION**

- Do not apply shock that exceeds the shock resistance described in the general specifications during transportation since the products are precision devices. Doing so may cause failure of the module.
- The halogens (such as fluorine, chlorine, bromine, and iodine), which are contained in a fumigant used for disinfection and pest control of wood packaging materials, may cause failure of the products. Prevent the entry of fumigant residues into the product or consider other methods (such as heat treatment) instead of fumigation. The disinfection and pest control measures must be applied to unprocessed raw wood.

## EMC and Low Voltage Directives

Compliance with the EMC Directive, which is one of the EU directives, has been mandatory for products sold within EU member states since 1996 as well as compliance with the Low Voltage Directive since 1997.

For products compliant to the EMC and Low Voltage Directives, their manufacturers are required to declare compliance and affix the CE marking.

In some other countries and regions, manufacturers are required to make their products compliant with applicable laws or regulations and attach a certification mark on the products as well (such as UK Conformity Assessed (UKCA) marking in the UK, and Korea Certification (KC) marking in South Korea).

#### (1) Sales representative in EU member states

The sales representative in EU member states is:

Company: MITSUBISHI ELECTRIC EUROPE B.V.

Address: Mitsubishi-Electric-Platz 1, 40882 Ratingen, Germany

#### (2) Method of ensuring compliance

To ensure that FA Goods products maintain EMC and Low Voltage Directives when incorporated into other machinery or equipment, certain measures may be necessary. Please refer to "EMC and Low Voltage Directives Compliant Manual" (50D-FA9010-108).

## REVISIONS

\*The manual number is given on the bottom left of the last page.

Print Date	*Manual Number	Revision
January, 2013	50D-FA9010-123	First edition
March, 2013	50D-FA9010-123-A	<u>Added or modified parts</u> SAFETY PRECAUTIONS
May, 2015	50D-FA9010-123-B	<u>Added or modified parts</u> EMC and Low Voltage Directives, Table of contents, 2. GENERAL SPECIFICATIONS, 3. PERFORMANCE SPECIFICATIONS, 8. CONNECTABLE MODULES AND CABLES
March, 2018	50D-FA9010-123-C	<u>Added or modified parts</u> Product addition: FA-Q6TCA, SAFETY PRECAUTIONS, EMC and Low Voltage Directives, REVISIONS, 3. PERFORMANCE SPECIFICATIONS, 4. CONNECTABLE MODULES AND CABLES, 5. EXTERNAL DIMENSIONS, 6. INSTALLATION ORIENTATION, 7. CONNECTING METHOD, 13. TRADEMARKS
November, 2021	50D-FA9010-123-D	<u>Added or modified parts</u> Product addition : FA1-AT1B4Y1TE,FA1-AT1B4Y1TB SAFETY PRECAUTIONS, Table of contents, 1. INTRODUCTION, 3. PERFORMANCE SPECIFICATIONS, 4. CONNECTABLE MODULES AND CABLES, 5. EXTERNAL DIMENSIONS, 6. INSTALLATION ORIENTATION, 7. CONNECTING METHOD, 8. APPLICABLE SOLDERLESS TERMINALS AND FERRULE
May, 2022	50D-FA9010-123-E	<u>Added or modified parts</u> 3. PERFORMANCE SPECIFICATIONS

This manual confers no industrial property rights or any rights of any other kind, nor does it confer any patent licenses. Mitsubishi Electric Engineering cannot be held responsible for any problems involving industrial property rights which may occur as a result of using the contents noted in this manual.

# CONTENTS

<b>CONTENTS</b> .....	7
<b>1. INTRODUCTION</b> .....	8
<b>2. GENERAL SPECIFICATIONS</b> .....	8
<b>3. PERFORMANCE SPECIFICATIONS</b> .....	9
3-1. Output type 8-channel installation base, screw terminal block type (FA-ATB8YTB).....	9
3-2. Output type 4-channel installation base, spring clamp terminal block type (FA1-AT1B4Y1TE).....	10
3-3. Output type 4-channel installation base, screw terminal block type (FA1-AT1B4Y1TB).....	11
3-4. Voltage output signal conversion module (current input) (FA-ATSAM1YV****).....	12
3-5. Current input Signal conversion module (current input) (FA-ATSAM1YA****).....	13
3-6. Voltage output signal conversion module (voltage input) (FA-ATSVM1YV****).....	14
3-7. Current input Signal conversion module (voltage input) (FA-ATSVM1YA****).....	15
3-8. Pass-through module (FA-ATFTMX).....	16
3-9. Terminal block ↔ connector conversion adapter (FA-Q6TCA).....	16
<b>4. CONNECTABLE MODULES AND CABLES</b> .....	17
<b>5. EXTERNAL DIMENSIONS</b> .....	19
5-1. Output type 8-channel installation base, screw terminal block type FA-ATB8YTB.....	19
5-2. Output type 4-channel installation base, spring clamp terminal block type (FA1-AT1B4Y1TE).....	20
5-3. Output type 4-channel installation base, screw terminal block type (FA1-AT1B4Y1TB).....	20
5-4. Signal conversion module (FA-ATS*M1Y****), pass-through module (FA-ATFTMX).....	21
5-5. Terminal block ↔ connector conversion adapter (FA-Q6TCA).....	21
<b>6. INSTALLATION ORIENTATION</b> .....	21
<b>7. CONNECTING METHOD</b> .....	23
7-1. Connection example with a terminal block module of a programmable controller.....	23
7-1-1. When a cable with a terminal block is used.....	23
7-1-2. When a terminal block to connector conversion adapter is used.....	24
7-1-3. When a discrete cable is used.....	25
7-2. Connection example when an additional 4-channel base is used.....	26
7-3. Mounting/removing a signal conversion module.....	27
7-4. Wiring to a spring clamp terminal block.....	28
<b>8. APPLICABLE SOLDERLESS TERMINALS</b> .....	30
<b>9. PRECAUTIONS</b> .....	31
<b>10. GRATIS WARRANTY TERMS AND GRATIS WARRANTY RANGE</b> .....	32
<b>11. REPAIRABLE PERIOD AFTER DISCONTINUATION OF PRODUCTION</b> .....	32
<b>12. EXCLUSION FROM LIABILITY FOR OPPORTUNITY LOSS AND SECONDARY LOSS</b> .....	32
<b>13. TRADEMARKS</b> .....	32

## 1. INTRODUCTION

This manual describes the specifications and handling of the analog signal converter, which consists of the installation base (FA-ATB8YTB, FA1-AT1B4Y1TE, FA1-AT1B4Y1TB), the signal conversion module (FA-ATS\*M1Y\*\*\*\*\*) and/or the I/O signal pass-through module (FA-ATFTMX), and the terminal block ↔ connector conversion adapter for MELSEC-Q series terminal block module (FA-Q6TCA).

The analog signal converter includes the signal conversion module mounted to the installation base. The analog signal converter insulates signals (1 to 5VDC, 4 to 20mADC) between input and output terminals, and among the channels, converts them to analog output signals, and outputs the converted signals.

## 2. GENERAL SPECIFICATIONS

Item		Specifications	
Operating surrounding air temperature		0 to 55°C	
Storage ambient temperature		-25 to 75°C	
Operating ambient humidity		5 to 95% RH, non-condensing	
Storage ambient humidity		5 to 95% RH, non-condensing	
Vibration resistance	Compliance with standard	JIS B 3502, IEC 61131-2	
	Under intermittent vibration	5 to 8.4Hz	Half amplitude: 3.5mm
		8.4 to 150Hz	Constant acceleration: 9.8m/s <sup>2</sup> (1G)
		Sweep count	10 times each in X, Y, and Z directions
	Under continuous vibration	5 to 8.4Hz	Half amplitude: 1.75mm
		8.4 to 150Hz	Constant acceleration: 4.9m/s <sup>2</sup> (0.5G)
Sweep count		—	
Shock resistance		Compliant with JIS B 3502 and IEC61131-2 (147m/s <sup>2</sup> (15G), 3 times each in X, Y, and Z directions)	
Operating atmosphere		No corrosive gas	
Operating altitude <sup>*1</sup>		2,000m or lower	
Installation location		Inside the control panel <sup>*4</sup> , Indoor use	
Overvoltage category <sup>*2</sup>		II or lower	
Pollution level <sup>*3</sup>		2 or lower	

\*1 : Do not use or store the module under the atmospheric pressure greater than that at an altitude of 0m.

\*2 : Indicates the section of the power supply to which the equipment is assumed to be connected, between the public power grid and the machinery within the premises.

\*3 : This is a guideline indicating the degree of the generation of conducting substances in the environment in which a device is used.

\*4 : The enclosure is suitably designed for those specific environmental conditions, as applicable, and enclosure rate meets IP20 and minimum type 1 of UL 50.



# 3. PERFORMANCE SPECIFICATIONS

## 3-1. Output type 8-channel installation base, screw terminal block type (FA-ATB8YTB)

Item	Model	FA-ATB8YTB
Number of slots		8
Terminal block	Terminal block screw	M3 screw, 7.62mm pitch, spring-up screw with finger protector cover Tightening torque range: 58.8 to 88.2N·cm (6 to 9kgf·cm, 5.22 to 7.5lbf·in), UL standard conformity tightening torque: 59N·cm, 5.22lbf·in
	Applicable wire	22 to 14 AWG: 0.3 to 2.0mm <sup>2</sup> (when solderless terminals are used)
Installation method	Screw	M4 × 0.7mm × 20mm or more Tightening torque range: 78 to 118N·cm (8 to 12kgf·cm, 7 to 10lbf·in)
	DIN rail	Applicable DIN rail: TH35-7.5Fe, TH35-7.5Al (compliant with IEC 60715)
External power supply		24VDC±10%
Current consumption (24VDC)		6mA or less (not including current consumption of the module, the programmable controller, and the monitor device)
Withstand voltage, insulation resistance		750VAC for 1 minute, 10MΩ or higher between input/output/power supply
Weight		Approx. 320g

\*1: Mount a dummy module onto an unused slot to allow no empty slot.

\*2: When connecting a cable to the installation base, push the cable connector in until it is locked. Failure to do so may cause poor contact.

\*3: When the output of the programmable controller is within a range of 4 to 20mA and the FA-ATFTMX signal pass-through module is used, the voltage value corresponding to the input resistance of the connected device is detected as a monitor output. The current value can be calculated by dividing the detected voltage by the input resistance.

### Block diagram

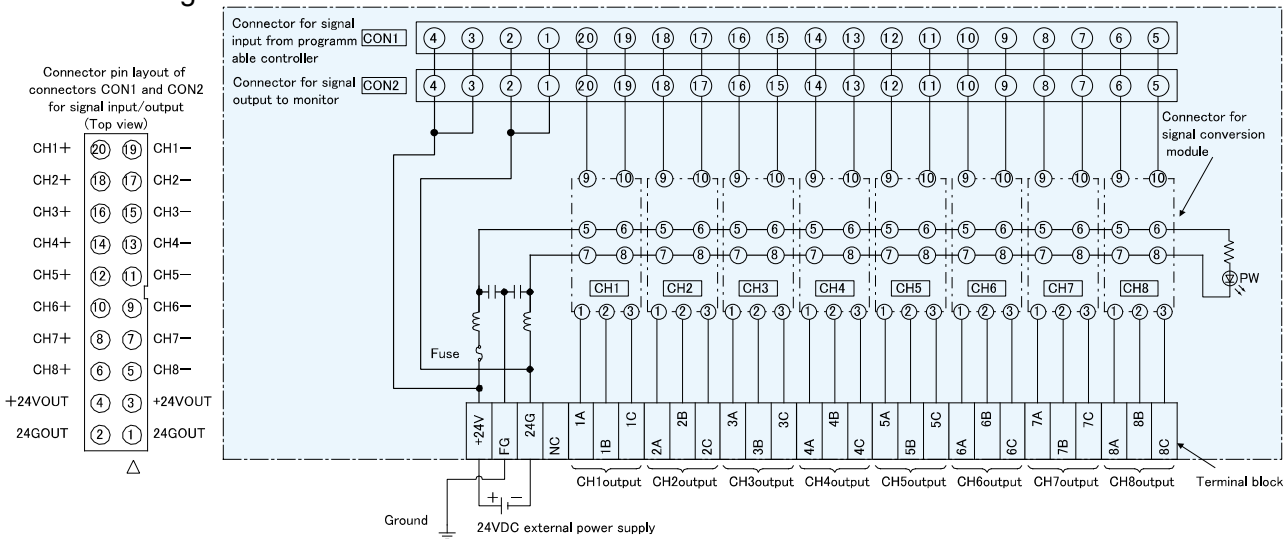

### Notes:

- For a device connected to a monitor output, use a device with sufficiently large input resistance. (Input resistance of 1MΩ or more is recommended.) The monitor output signal is 1 to 5V.
- Use shielded cables for external wirings.
- Use an output signal conversion device. Using an input signal conversion device incorrectly may damage the product.
- An external power supply is connected between CON1 and CON2.

When a power supply is not used, apply short-circuit protection.

·Power supply terminal

For 24V: Pin No.3 or 4 For 24G: pin No.1 or 2

·Short-circuit protection

- 1) Set the connector on the programmable controller and monitor device side to NC (No connection).
- 2) Insulate pins at wire end for NCs.

Insulate each pin so that the conductive part is not exposed.

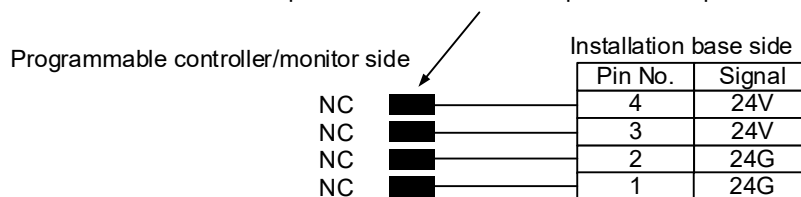

### 3-2. Output type 4-channel installation base, spring clamp terminal block type (FA1-AT1B4Y1TE)

Item		Model name	FA1-AT1B4Y1TE
Number of slots			4
Terminal block	Applicable wire *1	When a ferrule is not used (stranded wire or solid wire)	0.2 to 1.5mm <sup>2</sup> (24 to 16 AWG), Copper wire with a temperature rating of 75°C or more
		When a ferrule is used (stranded wire)	0.25 to 1.5mm <sup>2</sup> (24 to 16 AWG), Copper wire with a temperature rating of 75°C or more
Wire strip length			10mm
Module mounting	Mounting screws		M4 × 0.7mm × 22mm or greater Tightening torque range: 78 to 118N·cm (8 to 12kgf·cm)
	DIN rail		Applicable DIN rail TH35-7.5Fe, TH35-7.5Al (compliant with IEC 60715)
External supply power			24VDC±10% (ripple ratio: within 5%, SELV and LIM or CLASS 2)
Current consumption (24VDC)			6mA or less (not including current consumption by the conversion device, the Signal through device, the programmable controller, and the monitor equipment)
Withstand voltage/insulation resistance			Between input/output/power supply: 500VAC for 1 minute, 10MΩ or more
Weight			About 160g

\*1 : Select wires depending on the current value used.

#### ●Block diagram

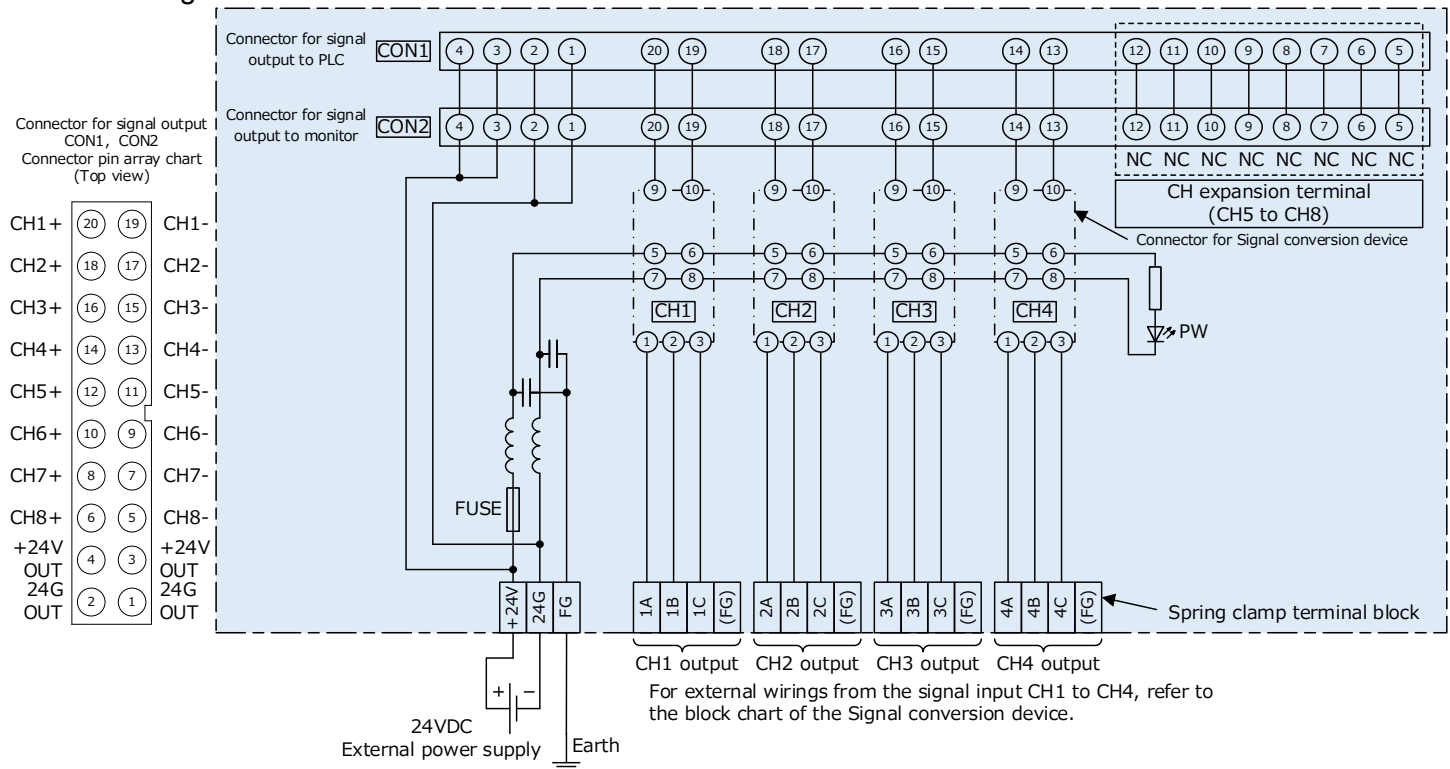

#### Notes:

- For a device connected to a monitor output, use a device with sufficiently large input resistance. (Input resistance of 1MΩ or more is recommended.) The monitor output signal is 1 to 5V.
- Use shielded cables for external wirings.
- Use an output signal conversion device. Using an input signal conversion device incorrectly may damage the product.
- An external power supply is connected between CON1 and CON2.

When a power supply is not used, apply short-circuit protection.

· Power supply terminal

For 24V: Pin No.3 or 4 For 24G: pin No.1 or 2

· Short-circuit protection

- 1) Set the connector on the programmable controller and monitor device side to NC (No connection).
- 2) Insulate pins at wire end for NCs.

Insulate each pin so that the conductive part is not exposed.

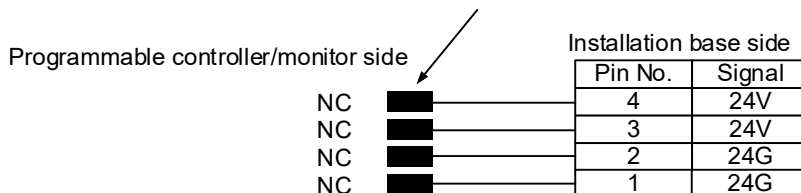

### 3-3. Output type 4-channel installation base, screw terminal block type (FA1-AT1B4Y1TB)

Item		Model name	FA1-AT1B4Y1TB
Number of slots			4
Terminal block	Terminal screw		M3 screw, Pitch of 7.62mm, Self tightening screw with finger protector cover
	Applicable wire *1		0.3 to 2.0mm <sup>2</sup> (22 to 14 AWG), Copper wire with a temperature rating of 75°C or more
	Tightening torque		58.8 to 88.2N·m (6 to 9kgf·cm, 5.22 to 7.5lbf·in, UL standard conformity tightening torque : 59N·m , 5.22 lbf·in.)
Module mounting	Mounting screws		M4 × 0.7mm × 22mm or greater Tightening torque range: 78 to 118N·m (8 to 12kgf·cm)
	DIN rail		Applicable DIN rail : TH35-7.5Fe, TH35-7.5Al (compliant with IEC 60715)
External supply power			24VDC±10% (ripple ratio: within 5%, SELV and LIM or CLASS 2)
Current consumption (24VDC)			6mA or less (not including current consumption by the conversion device, the Signal through device, the programmable controller, and the monitor equipment)
Withstand voltage/insulation resistance			Between input/output/power supply: 500VAC for 1 minute, 10MΩ or more
Weight			About 220g

\*1 : Select wires depending on the current value used.

#### ●Block diagram

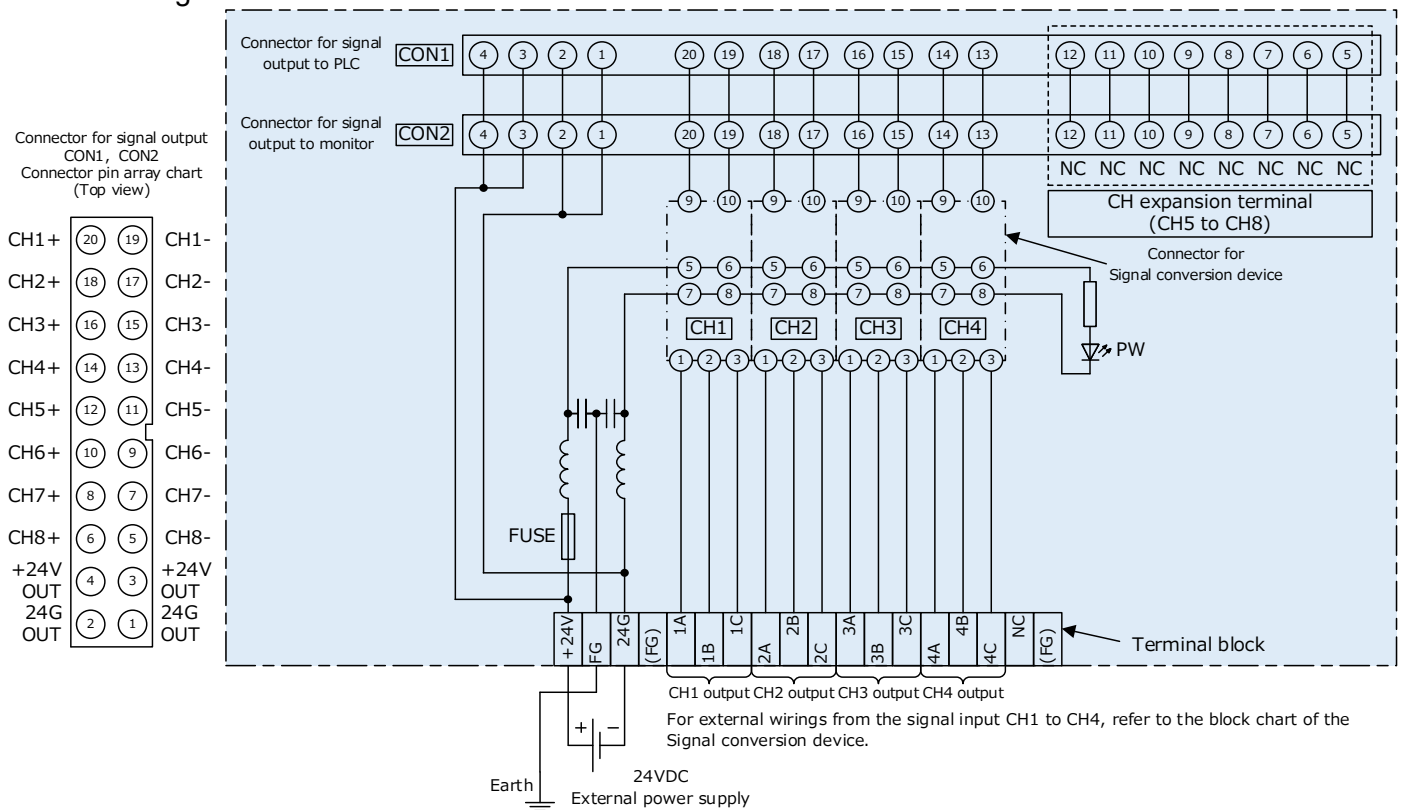

#### Notes:

- For a device connected to a monitor output, use a device with sufficiently large input resistance. (Input resistance of 1MΩ or more is recommended.) The monitor output signal is 1 to 5V.
- Use shielded cables for external wirings.
- Use an output signal conversion device. Using an input signal conversion device incorrectly may damage the product.
- An external power supply is connected between CON1 and CON2.

When a power supply is not used, apply short-circuit protection.

·Power supply terminal

For 24V: Pin No.3 or 4 For 24G: pin No.1 or 2

·Short-circuit protection

- 1) Set the connector on the programmable controller and monitor device side to NC (No connection).
- 2) Insulate pins at wire end for NCs.

Insulate each pin so that the conductive part is not exposed.

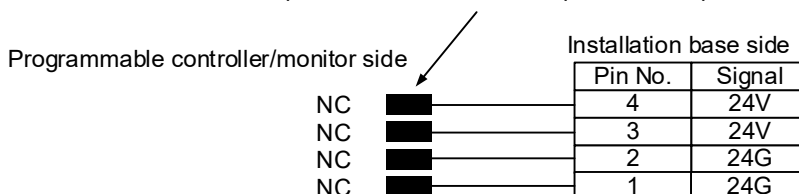

### 3-4. Voltage output signal conversion module (current input) (FA-ATSAM1YV\*\*\*\*)

Item	Model			
	FA-ATSAM1YV05	FA-ATSAM1YV15	FA-ATSAM1YV010	FA-ATSAM1YV1010
Number of points	1 point (1 channel)			
Input (Programmable controller side)	Input range	4 to 20mA		
	Input resistance	250Ω		
Accuracy (to full-scale)	Reference accuracy	±0.1% or less (ambient temperature 25°C±5°C)		
	Temperature characteristics	±0.015% / °C or less		
Output	Output signal	0 to 5V	1 to 5V	0 to 10V
	Output allowable load resistance	2.5kΩ or more		
	Disconnection detection function	None		
Response speed*1	15ms or less			
Zero/span adjustment	Zero adjustment range: -2 to 2%, span adjustment range: 98 to 102%			
Power supply	24VDC±10% (supplied from the installation base)			
Current consumption (24VDC)	45mA or less			
Insulation method	Transformer			
Withstand voltage, insulation resistance	750VAC for 1 minute, 10MΩ or higher between input/output/power supply			
Weight	Approx. 40g	Approx. 40g	Approx. 40g	Approx. 40g

\*1: A time from when a startup pulse is input until the output level reaches 90%

#### ●Block diagram

- Output signal from a programmable controller
- Output signal for monitor (MIL 20P connector side)

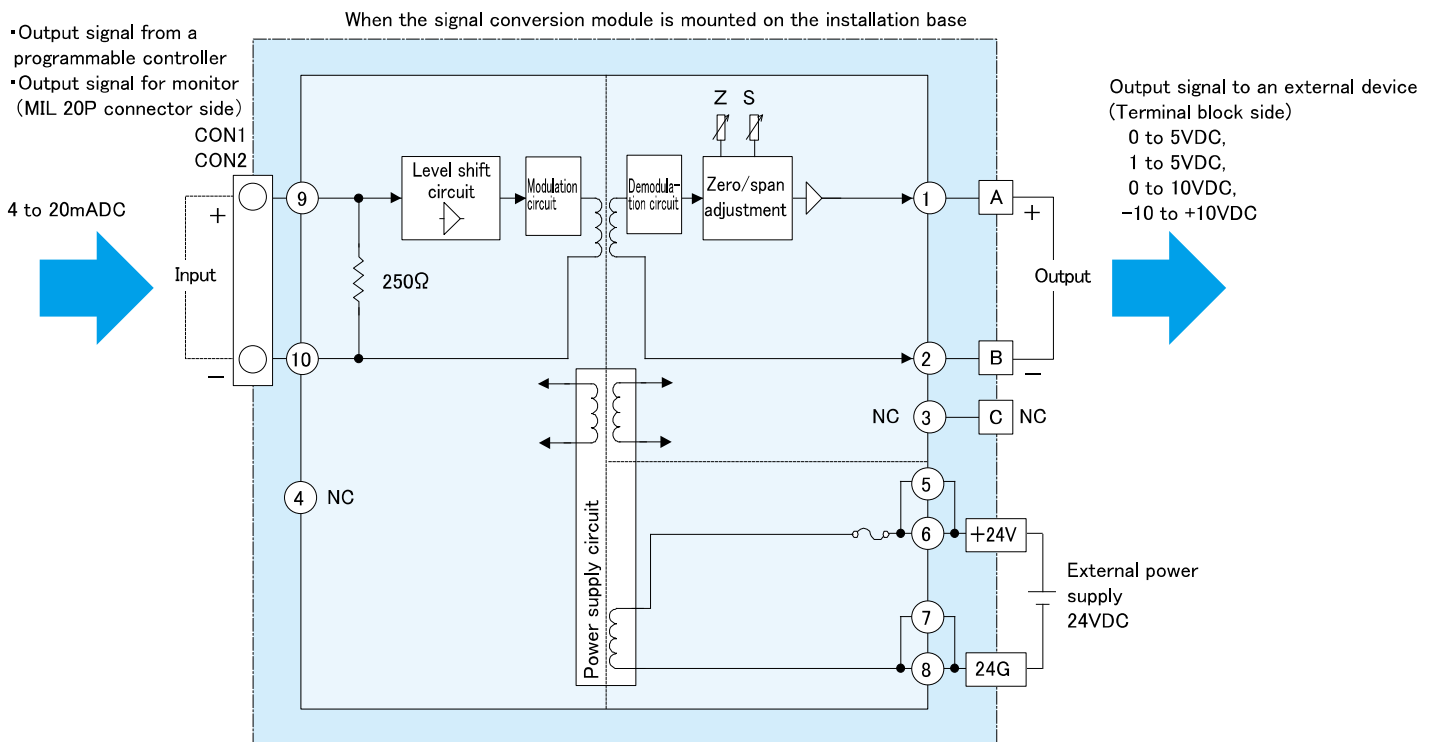

### 3-5. Current input Signal conversion module (current input) (FA-ATSAM1YA\*\*\*\*)

Model		FA-ATSAM1YA020	FA-ATSAM1YA420
Number of points		1 point (1 channel)	
Input (Programmable controller side)	Input range	4 to 20mA	
	Input resistance	250Ω	
Accuracy (to full-scale)	Reference accuracy	±0.1% or less (Ambient temperature 25°C±5°C)	
	Temperature characteristics	±0.015% / °C or less	
Output	Output signal	0 to 20mA	4 to 20mA
	Output allowable load resistance	600Ω or less	
	Disconnection detection function	None	
Response speed <sup>*1</sup>		15ms or less	
Zero/span adjustment		Zero adjustment range: -2 to 2%, span adjustment range: 98 to 102%	
Power supply		24VDC±10% (supplied from the installation base)	
Current consumption (24VDC)		45mA or less	
Insulation method		Transformer	
Withstand voltage, insulation resistance		750VAC for 1 minute, 10MΩ or higher between input/output/power supply	
Weight		Approx. 40g	Approx. 40g

\*1: A time from when a startup pulse is input until the output level reaches 90%

#### ●Block diagram

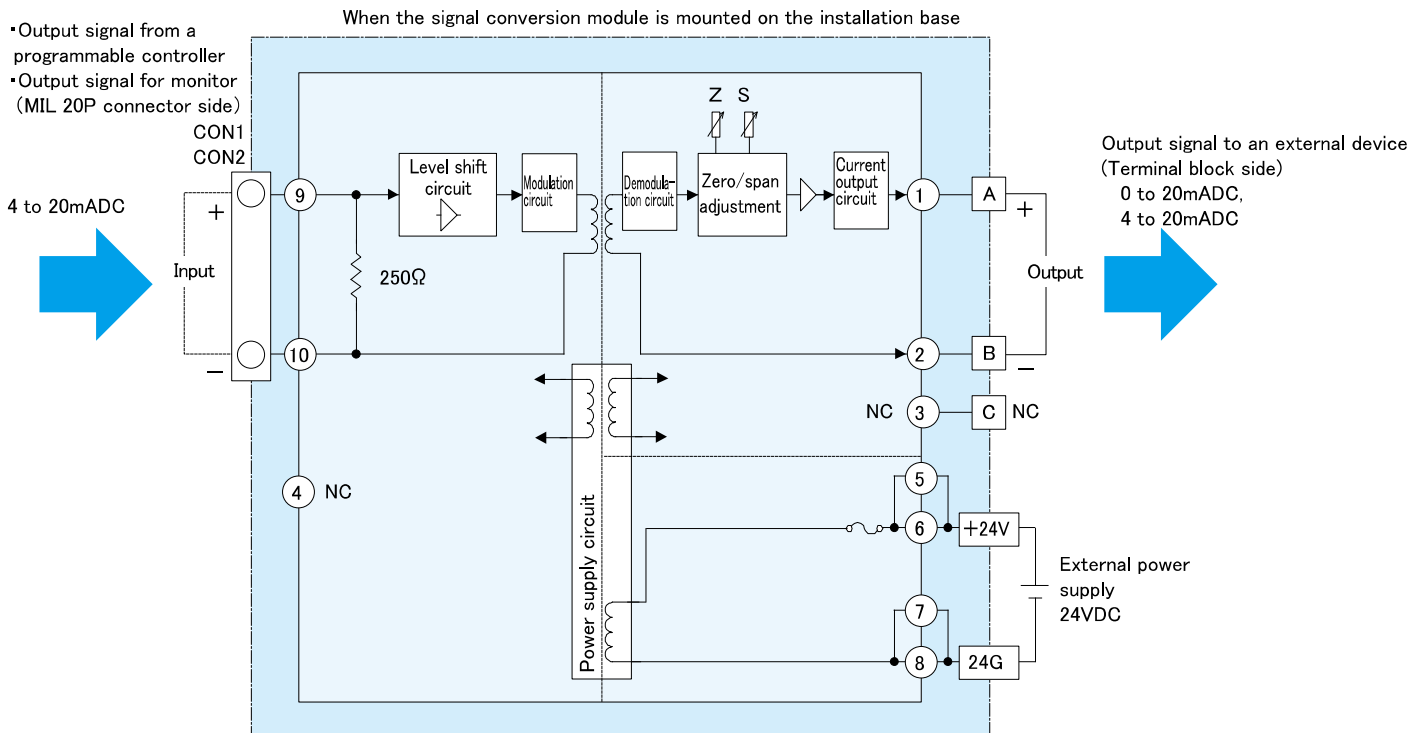

### 3-6. Voltage output signal conversion module (voltage input) (FA-ATSVM1YV\*\*\*\*)

Item		Model	FA-ATSVM1YV05	FA-ATSVM1YV15	FA-ATSVM1YV010	FA-ATSVM1YV1010
Number of points			1 point (1 channel)			
Input (Programmable controller side)	Input range		1 to 5V			
	Input resistance		1MΩ or more			
Accuracy (to full-scale)	Reference accuracy		±0.1% or less (Ambient temperature 25°C±5°C)			
	Temperature characteristics		±0.015% / °C or less			
Output	Output signal		0 to 5V	1 to 5V	0 to 10V	-10 to +10V
	Output allowable load resistance		2.5kΩ or more			
	Disconnection detection function		None			
Response speed*1			15ms or less			
Zero/span adjustment			Zero adjustment range: -2 to 2%, span adjustment range: 98 to 102%			
Power supply			24VDC±10% (supplied from the installation base)			
Current consumption (24VDC)			45mA or less			
Insulation method			Transformer			
Withstand voltage, insulation resistance			750VAC for 1 minute, 10MΩ or higher between input/output/power supply			
Weight			Approx. 40g	Approx. 40g	Approx. 40g	Approx. 40g

\*1: A time from when a startup pulse is input until the output level reaches 90%

#### ●Block diagram

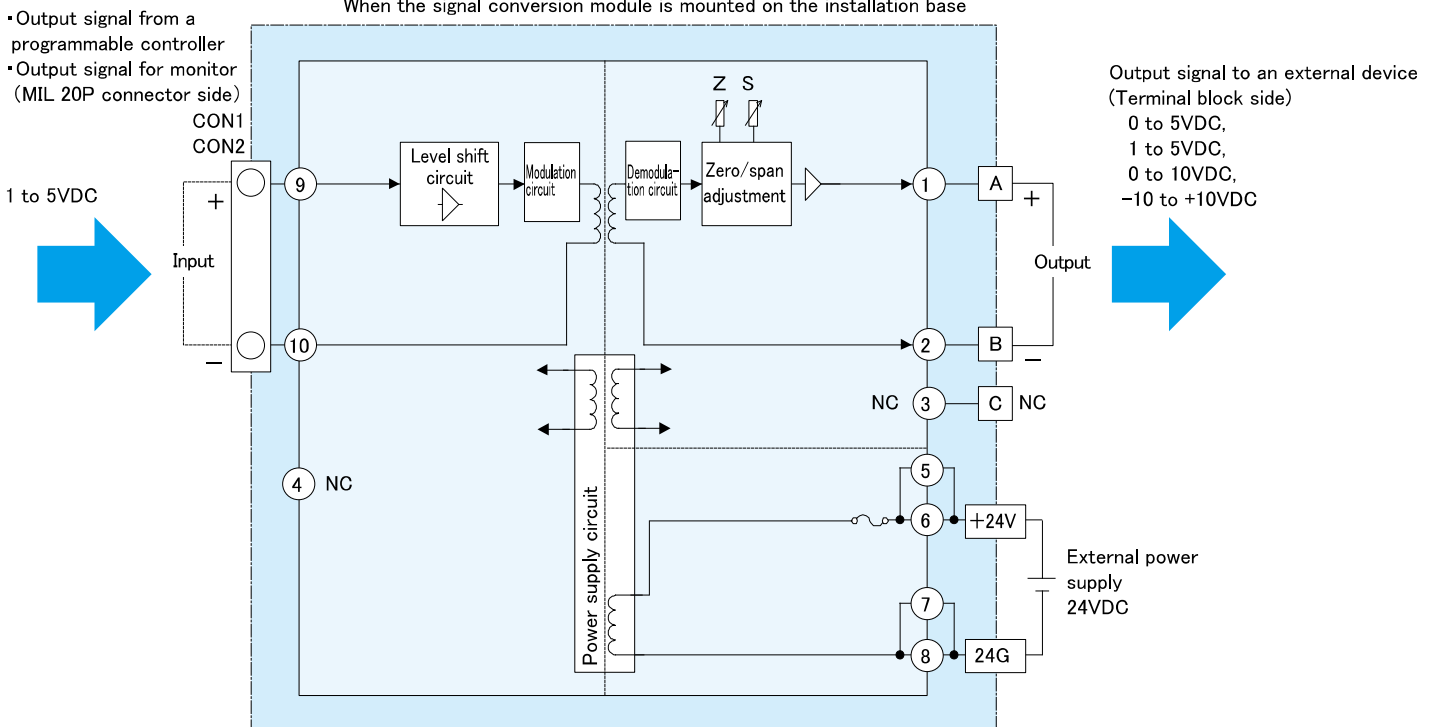

### 3-7. Current input Signal conversion module (voltage input) (FA-ATSVM1YA\*\*\*\*)

Model		FA-ATSVM1YA020	FA-ATSVM1YA420
Number of points		1 point (1 channel)	
Input (Programmable controller side)	Input range	1 to 5V	
	Input resistance	1MΩ or more	
Accuracy (to full-scale)	Reference accuracy	±0.1% or less (Ambient temperature 25°C±5°C)	
	Temperature characteristics	±0.015% / °C or less	
Output	Output signal	0 to 20mA	4 to 20mA
	Output allowable load resistance	600Ω or less	
	Disconnection detection function	None	
Response speed*1		15ms or less	
Zero/span adjustment		Zero adjustment range: -2 to 2%, span adjustment range: 98 to 102%	
Power supply		24VDC±10% (supplied from the installation base)	
Current consumption (24VDC)		45mA or less	
Insulation method		Transformer	
Withstand voltage, insulation resistance		750VAC for 1 minute, 10MΩ or higher between input/output/power supply	
Weight		Approx. 40g	Approx. 40g

\*1: A time from when a startup pulse is input until the output level reaches 90%

#### ●Block diagram

- Output signal from a programmable controller
- Output signal for monitor (MIL 20P connector side)

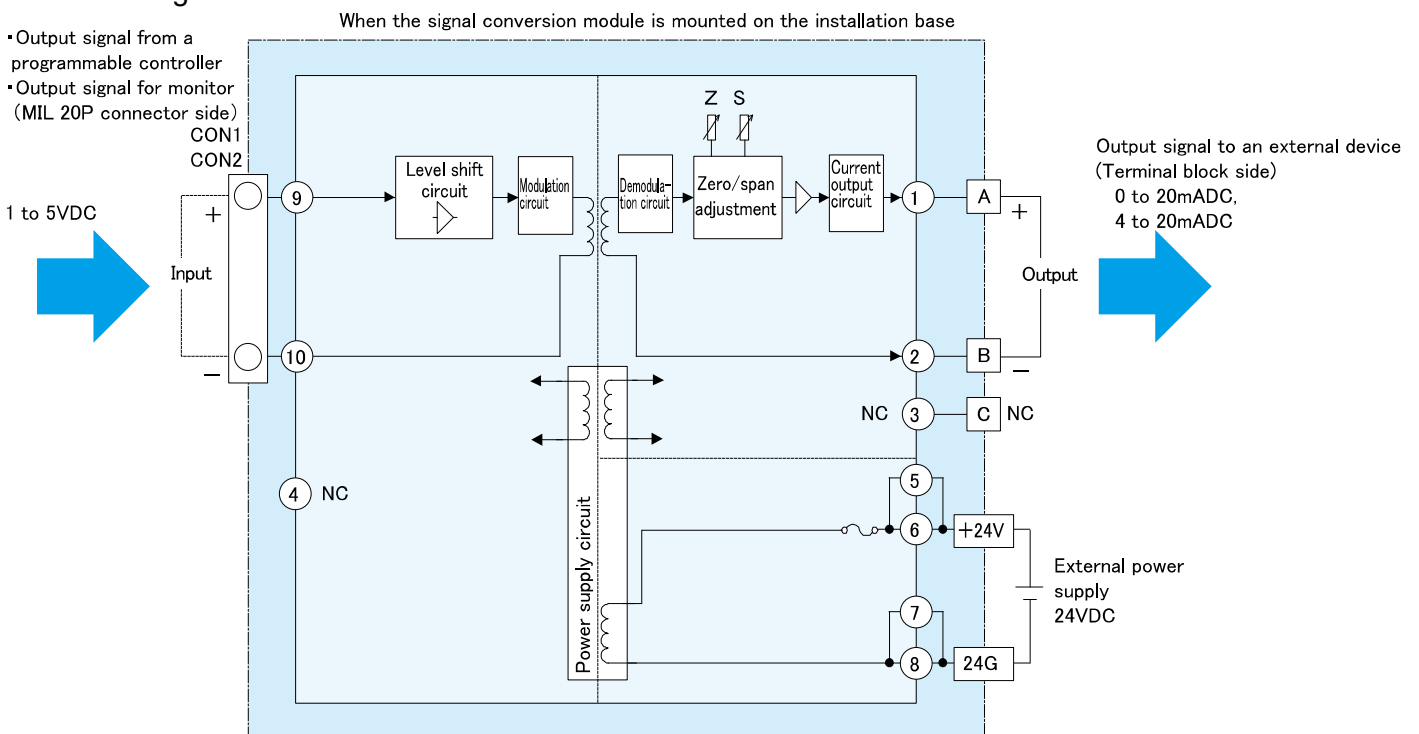

### 3-8. Pass-through module (FA-ATFTMY)

Item		Model	FA-ATFTMY	
Number of points			1 point (1 channel)	
Conversion type			When signals are passed through	When current is converted to voltage*1
Input	Resistance		—	250Ω
	Resistor accuracy		—	±0.1% or less
	Temperature characteristics of resistor		—	±0.0025%/°C or less
Allowable I/O signal			Voltage: 10V or less, Current: 20mA or less	
Weight			Approx. 30g	

\*1: When current is converted to voltage, short across terminals A and C of the installation base terminal block.

#### ●Block diagram

Voltage/Current output: when signals are passed through

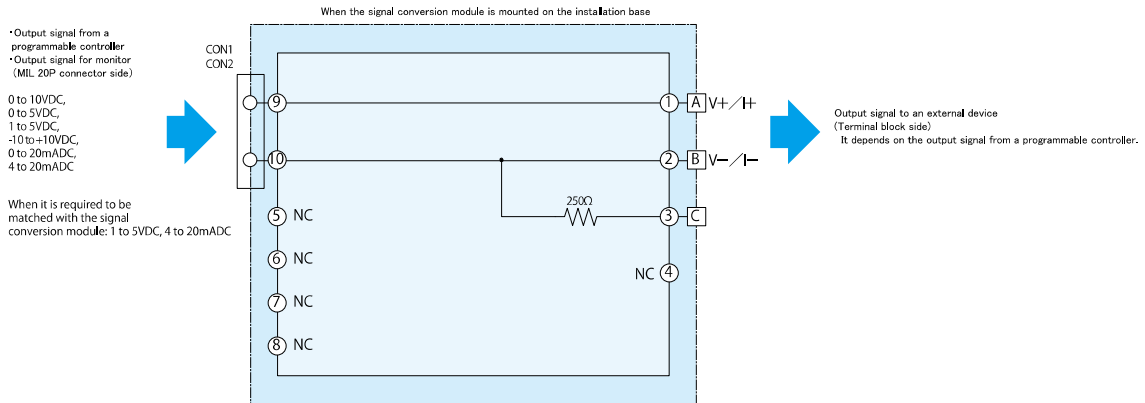

Current output: when current is converted to voltage

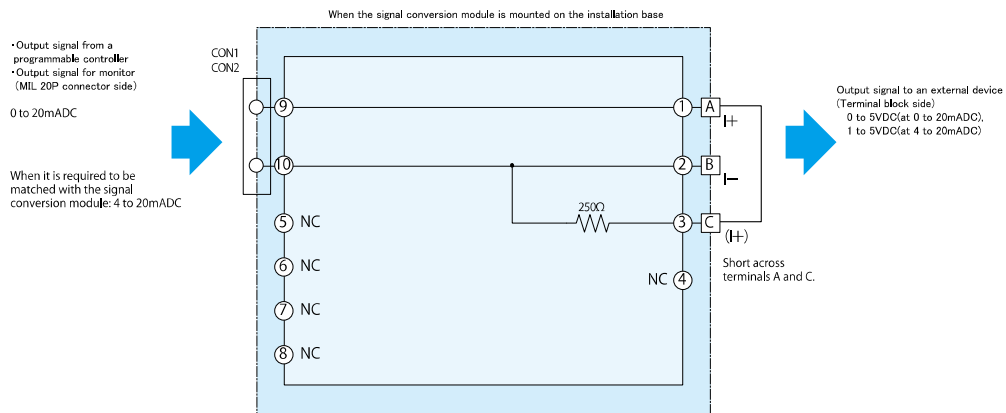

### 3-9. Terminal block ↔ connector conversion adapter (FA-Q6TCA)

Item		Model	FA-Q6TCA
Rated voltage, rated current			Voltage: 121VDC / 264VAC, Current: 2A (Terminal No.1 to 16) / 8A (Terminal No.17, 18)
Tightening torque			66 to 89N·cm (7 to 9kgf·cm, 6.08 to 7.81lbf·in)
Weight			Approx. 80g



## 4. CONNECTABLE MODULES AND CABLES

Module model for a programmable controller		output range	Installation base	Signal conversion module	Cable model
MELSEC iQ-R series	R60DAI8	4 to 20mA	FA-ATB8YTB	Voltage output FA-ATSAM1Y05, FA-ATSAM1YV010, FA-ATSAM1YV15, FA-ATSAM1YV1010 Current output FA-ATSAM1YA020, FA-ATSAM1YA420 When signals are passed through FA-ATFTMX	FA-CBL**ATQ8YT
					FA-CBL**ATQ8YA *1
MELSEC-Q series	Q68DAIN	4 to 20mA			FA-CBL**ATQ8YT
					FA-CBL**ATQ8YA *1
MELSEC-L series	L60DAIL8	4 to 20mA			FA-CBL**ATYF
MELSEC-F series	FX3U-4DA	4 to 20mA			
	FX3U-4DA-ADP				
CC-Link IE TSN	NZGN2B-60DA4	4 to 20mA			
CC-Link IE Field	NZ2GFCE-60DAI8	4 to 20mA			
	NZ2GF2BN-60DA4				
CC-Link	AJ65SBT2B-64DA	4 to 20mA			
Programmable controllers from various manufacturers	General-purpose analog input module	4 to 20mA			
Computers from various manufacturers		4 to 20mA			
MELSEC iQ-R series	R60DAV8	1 to 5V	FA-ATB8YTB	Voltage output FA-ATSAM1Y05, FA-ATSAM1YV010, FA-ATSAM1YV15, FA-ATSAM1YV1010 Current output FA-ATSAM1YA020, FA-ATSAM1YA420 When signals are passed through FA-ATFTMX	FA-CBL**ATQ8YT
					FA-CBL**ATQ8YA *1
MELSEC-Q series	Q68DAVN	1 to 5V			FA-CBL**ATQ8YT
					FA-CBL**ATQ8YA *1
MELSEC-L series	L60DAVL8	1 to 5V			FA-CBL**ATYF
MELSEC-F series	FX3U-4DA	1 to 5V			FA-CBL**ATYF
	FX3U-4DA-ADP				
CC-Link IE TSN	NZGN2B-60DA4	1 to 5V			Use the cable that comes with the product.
	FA3-AT1T8Y-01C				
	FA3-AT1T8Y				
CC-Link IE Field	NZ2GFCE-60DAV8	1 to 5V			FA-CBL**ATYF
	NZ2GF2BN-60DA4				
CC-Link	AJ65SBT2B-64DA	1 to 5V			Use the cable that comes with the product.
	FA3-AT1C8Y-01C				
	FA3-AT1C8Y				
Programmable controllers from various manufacturers	General-purpose analog input module	1 to 5V	FA-CBL**ATYF		
Computers from various manufacturers		1 to 5V			

\*1: When the FA-Q6TCA is used on the MELSEC iQ-R series / MELSEC-Q series programmable controller side.

Module model for a programmable controller		Number of channels	output range	Cable for dispersed installation	Installation base	Signal conversion module	Cable model	
MELSEC iQ-R series	R60DAI8	8	4 to 20mA		FA1-AT1B4Y1TE, FA1-AT1B4Y1TB	Voltage output FA-ATSAM1Y05, FA-ATSAM1YV010, FA-ATSAM1YV15, FA-ATSAM1YV1010 Current output FA-ATSAM1YA020, FA-ATSAM1YA420 When signals are passed through FA-ATFTMX	FA-CBL**ATQ8YT	
	R60DAH4	4					FA-CBL**ATQ8YA *1	
							FA1-CB2L**AT4YA1T	
R60DA4	MELSEC-Q series	Q68DAIN	8				4 to 20mA	FA-CBL**ATQ8YT
Q64DAH		4	FA-CBL**ATQ8YA *1					
Q64DAN			FA1-CB2L**AT4YA1T					
MELSEC-L series	L60DA4	4	4 to 20mA				FA-CBL**ATYF	
MELSEC iQ-F series	FX5-4DA	4	4 to 20mA				FA2-CB2L**AT4YA1E	
MELSEC-F series	FX3U-4DA	4	4 to 20mA				FA-CBL**ATYF	
	FX3U-4DA-ADP							
CC-Link IE TSN	NZ2GN2S-60DA4	4	4 to 20mA				FA3-CB2L**AT4YA1E	
	NZ2GN2B-60DA4							
CC-Link IE Field	NZ2GF2BN-60DA4	4	4 to 20mA				FA-CBL**ATYF	
CC-Link	AJ65SBT2B-64DA	4	4 to 20mA					
Programmable controllers from various manufacturers	General-purpose analog input module	Differs depending on the module.	4 to 20mA					
Computers from various manufacturers			Differs depending on the computer.	4 to 20mA				
MELSEC iQ-R series	R60DAV8	8	1 to 5V		FA1-AT1B4Y1TE, FA1-AT1B4Y1TB	Voltage output FA-ATSAM1Y05, FA-ATSAM1YV010, FA-ATSAM1YV15, FA-ATSAM1YV1010 Current output FA-ATSAM1YA020, FA-ATSAM1YA420 When signals are passed through FA-ATFTMX	FA-CBL**ATQ8YT	
	R60DAH4	4					FA-CBL**ATQ8YA *1	
							FA1-CB2L**AT4YV1T	
MELSEC-Q series	Q68DAVN	8	1 to 5V				FA-CBL**ATQ8YT	
	Q64DAH	4	FA-CBL**ATQ8YA *1					
	Q64DAN		FA1-CB2L**AT4YV1T					
MELSEC-L series	L60DA4	4	1 to 5V				FA-CBL**ATYF	
MELSEC iQ-F series	FX5-4DA	4	1 to 5V				FA2-CB2L**AT4YV1E	
MELSEC-F series	FX3U-4DA	4	1 to 5V				FA-CBL**ATYF	
	FX3U-4DA-ADP							
CC-Link IE TSN	FA3-AT1T8Y-01C	8	1 to 5V				Use the cable that comes with the product.	
	FA3-AT1T8Y						FA3-CB2L**MM1H20	
	NZ2GN2S-60DA4	4					FA3-CB2L**AT4YV1E	
	NZ2GN2B-60DA4							
CC-Link IE Field	NZ2GF2BN-60DA4	4	1 to 5V				FA-CBL**ATYF	
CC-Link	FA3-AT1C8Y-01C	8	1 to 5V	Use the cable that comes with the product.				
	FA3-AT1C8Y			FA3-CB2L**MM1H20				
	AJ65SBT2B-64DA	4						
Programmable controllers from various manufacturers	General-purpose analog input module	Differs depending on the module.	1 to 5V	FA-CBL**ATYF				
Computers from various manufacturers			Differs depending on the module.		1 to 5V			

\*1: When the FA-Q6TCA is used on the MELSEC iQ-R series / MELSEC-Q series programmable controller side.

Module model for a programmable controller		Number of channels	output range	Cable for dispersed installation	Installation base	Signal conversion module	Cable model	
MELSEC iQ-R series	R60DAI8	8	4 to 20mA	FA1-CB2L**AT4EX	FA1-AT1B4Y1TE×2, FA1-AT1B4Y1TB×2	Voltage output FA-ATSAM1Y05, FA-ATSAM1YV010, FA-ATSAM1YV15, FA-ATSAM1YV1010 Current output FA-ATSAM1YA020, FA-ATSAM1YA420 When signals are passed through FA-ATFTMX	FA-CBL**ATQ8YT	
							FA-CBL**ATQ8YA *1	
MELSEC-Q series	Q68DAIN	8	4 to 20mA				FA-CBL**ATQ8YT	
							FA-CBL**ATQ8YA *1	
MELSEC-L series	L60DAIL8	8	4 to 20mA				FA-CBL**ATYF	
Programmable controllers from various manufacturers	General-purpose analog input module	Differs depending on the module.	4 to 20mA					
Computers from various manufacturers		Differs depending on the computer.	4 to 20mA					
MELSEC iQ-R series	R60DAV8	8	1 to 5V	FA1-CB2L**AT4EX	FA1-AT1B4Y1TE×2 FA1-AT1B4Y1TB×2	Voltage output FA-ATSAM1Y05, FA-ATSAM1YV010, FA-ATSAM1YV15, FA-ATSAM1YV1010 Current output FA-ATSAM1YA020, FA-ATSAM1YA420 When signals are passed through FA-ATFTMX	FA-CBL**ATQ8YT	
							FA-CBL**ATQ8YA *1	
MELSEC-Q series	Q68DAVN	8	1 to 5V				FA-CBL**ATQ8YT	
							FA-CBL**ATQ8YA *1	
MELSEC-L series	L60DAVL8	8	1 to 5V				FA-CBL**ATYF	
CC-Link IE TSN	FA3-AT1T8Y-01C	8	1 to 5V					Use the cable that comes with the product.
	FA3-AT1T8Y							FA3-CB2L**MM1H20
CC-Link	FA3-AT1C8Y-01C	8	1 to 5V				Use the cable that comes with the product.	
	FA3-AT1C8Y						FA3-CB2L**MM1H20	
	AJ65VBTCU-68DAVN	4					FA-CBL**ATYF	
Programmable controllers from various manufacturers	General-purpose analog input module	Differs depending on the module.	1 to 5V					
Computers from various manufacturers		Differs depending on the computer.	1 to 5V					

\*1: When the FA-Q6TCA is used on the MELSEC iQ-R series / MELSEC-Q series programmable controller side.

## 5. EXTERNAL DIMENSIONS

### 5-1. Output type 8-channel installation base, screw terminal block type FA-ATB8YT

[Unit : mm]

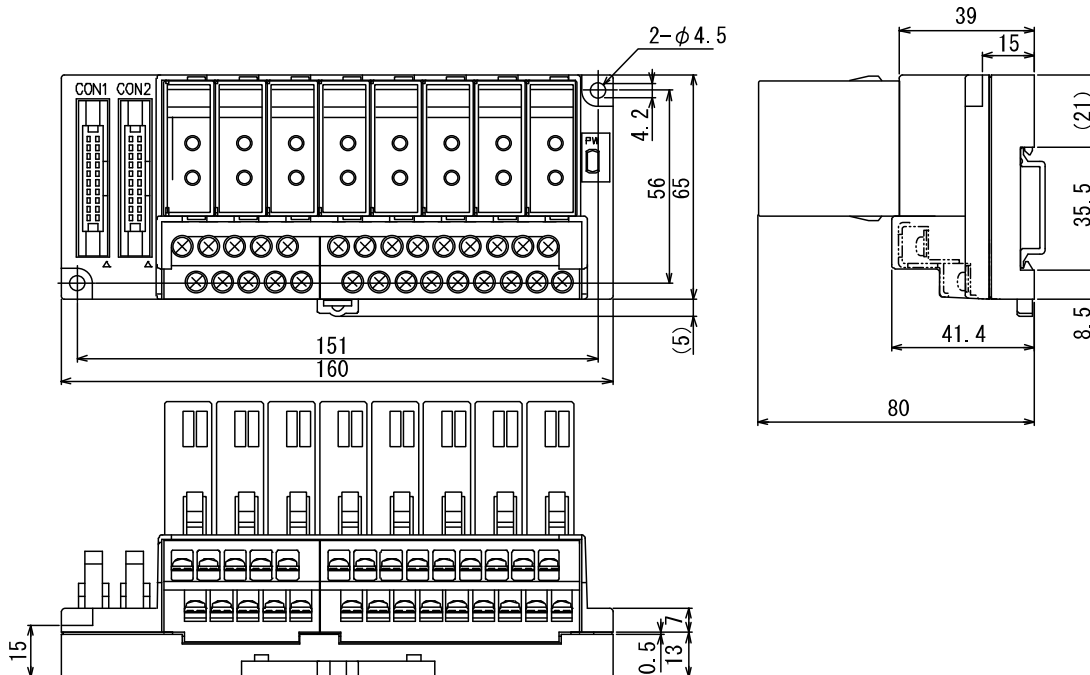

5-2. Output type 4-channel installation base, spring clamp terminal block type (FA1-AT1B4Y1TE)

[Unit : mm]

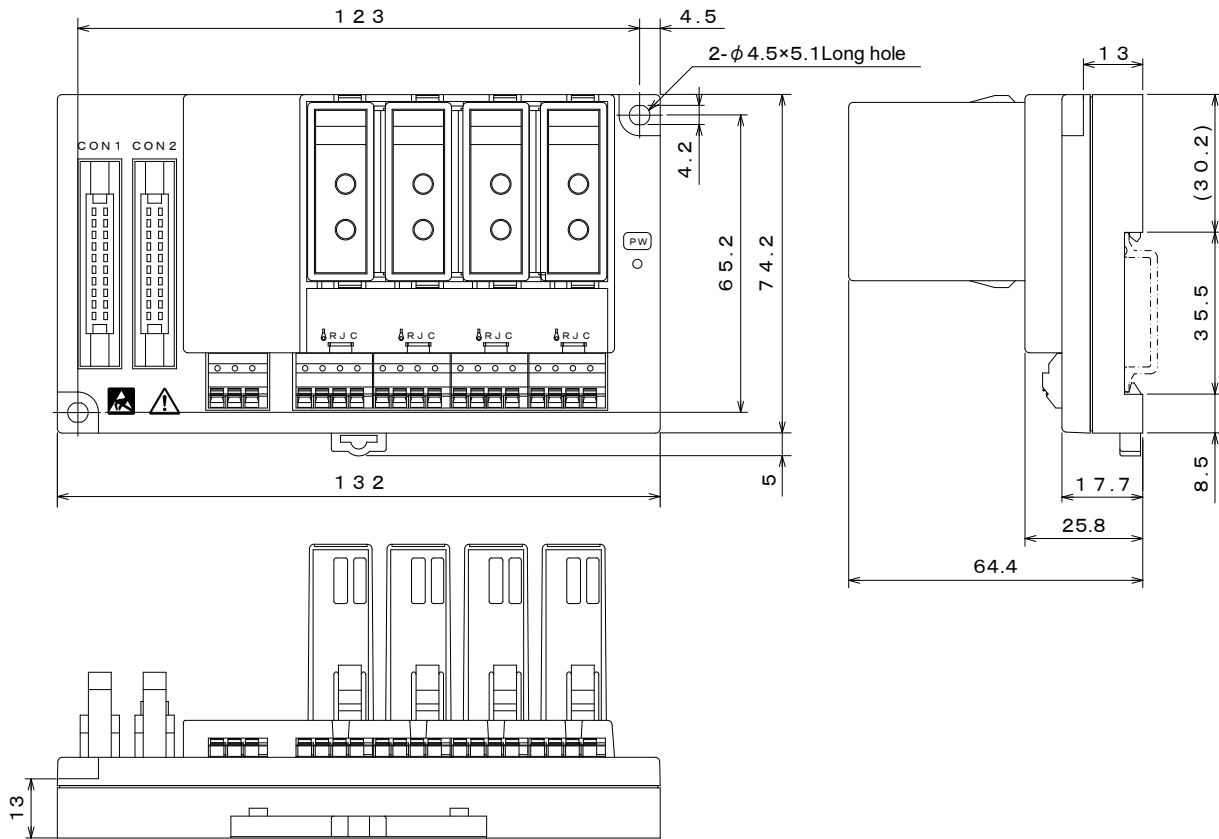

5-3. Output type 4-channel installation base, screw terminal block type (FA1-AT1B4Y1TB)

[Unit : mm]

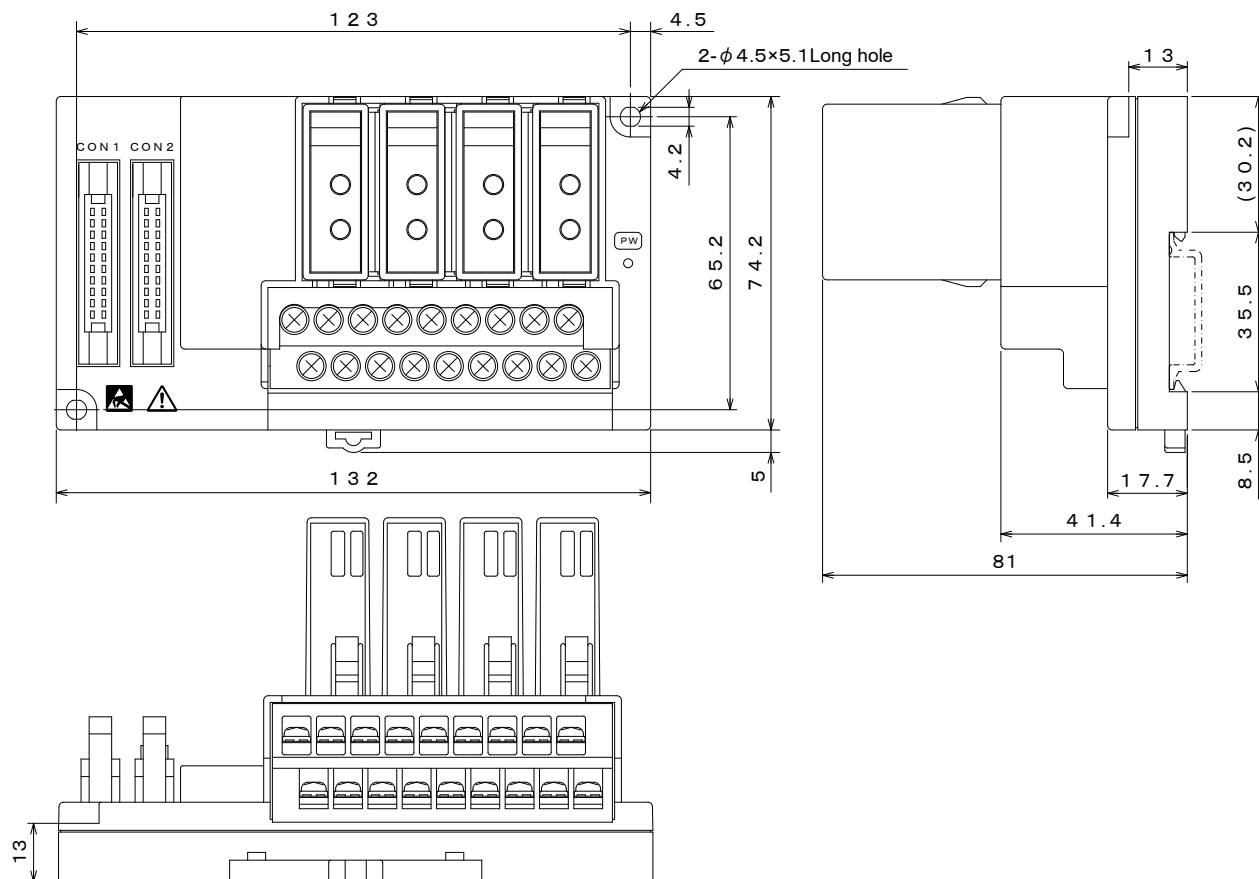

5-4. Signal conversion module (FA-ATS\*M1Y\*\*\*\*), pass-through module (FA-ATFTMXY)

[Unit : mm]

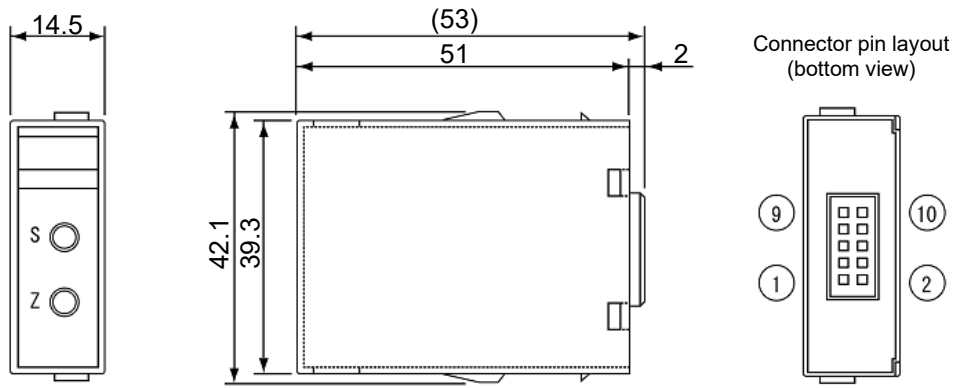

5-5. Terminal block ↔ connector conversion adapter (FA-Q6TCA)

[Unit : mm]

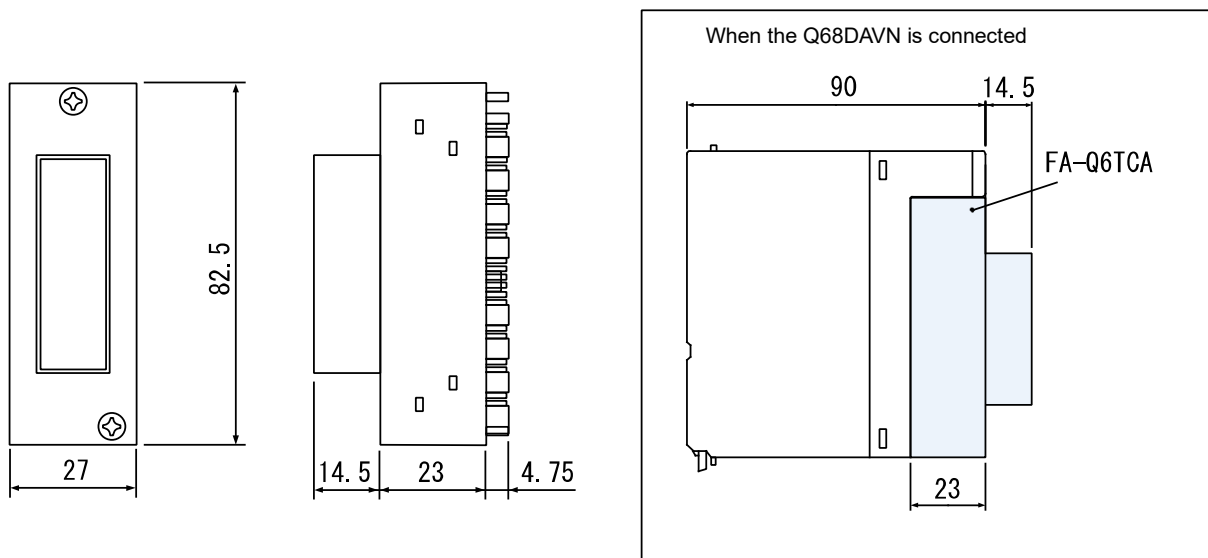

## 6. INSTALLATION ORIENTATION

6-1. Output type 8-channel installation base, screw terminal block type FA-ATB8YTB

Horizontal installation

Vertical installation

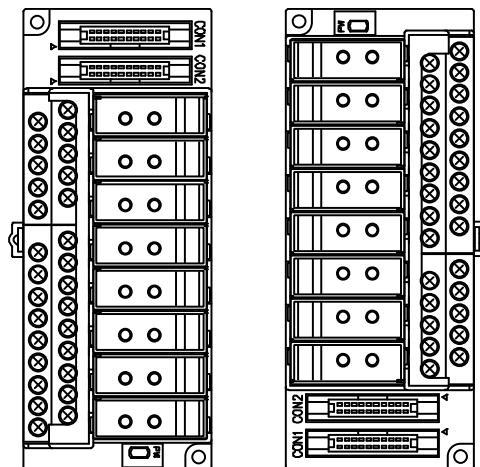
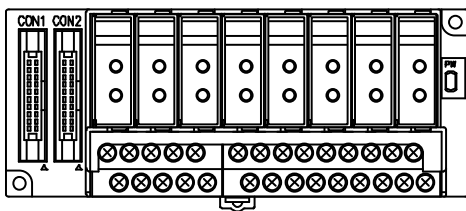

Upward installation

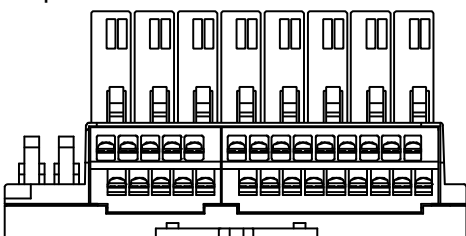

6-2. Output type 4-channel installation base, spring clamp terminal block type (FA1-AT1B4Y1TE)

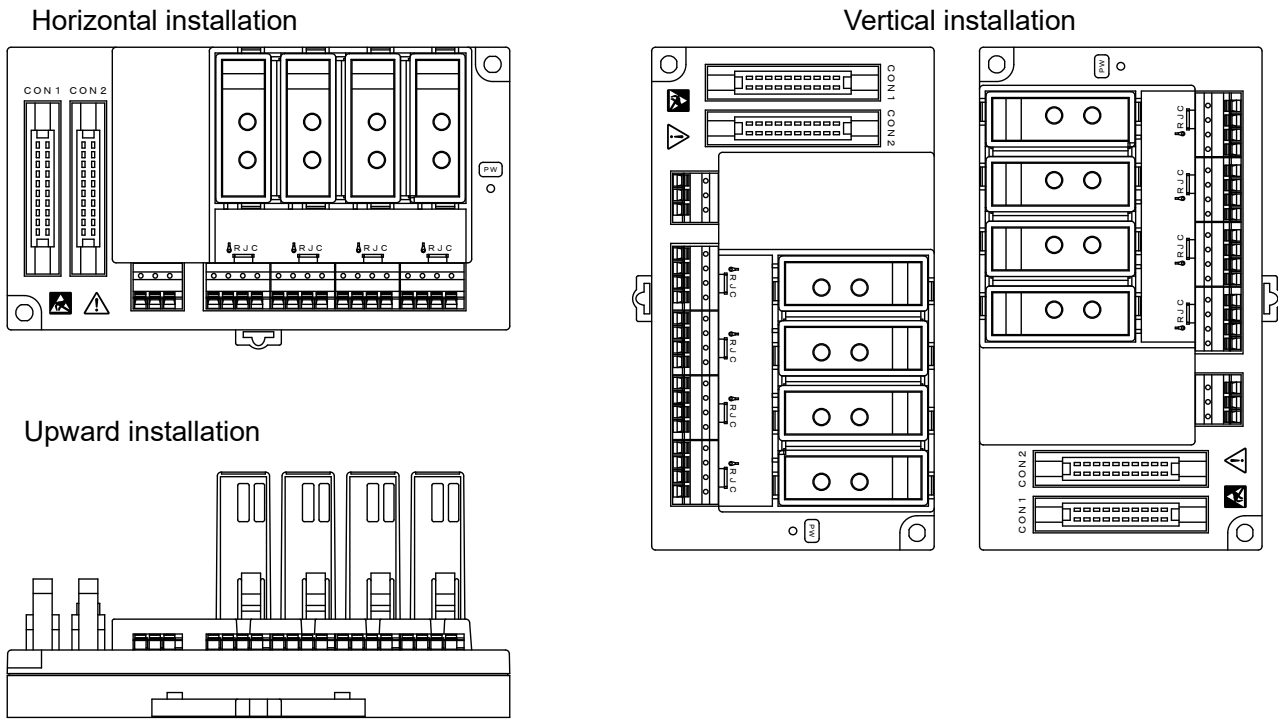

6-3. Output type 4-channel installation base, screw terminal block type (FA1-AT1B4Y1TB)

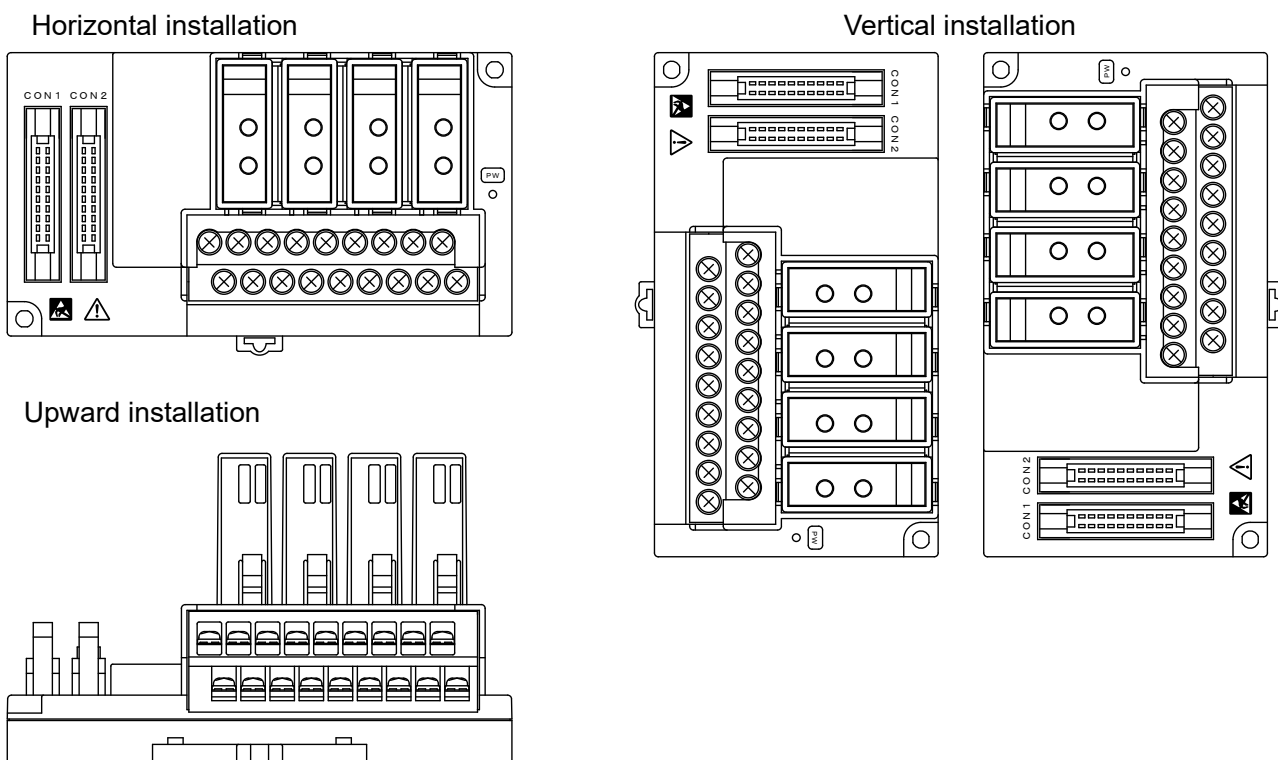

## 7. CONNECTING METHOD

### 7-1. Connection example with a terminal block module of a programmable controller

#### 7-1-1. When a cable with a terminal block is used

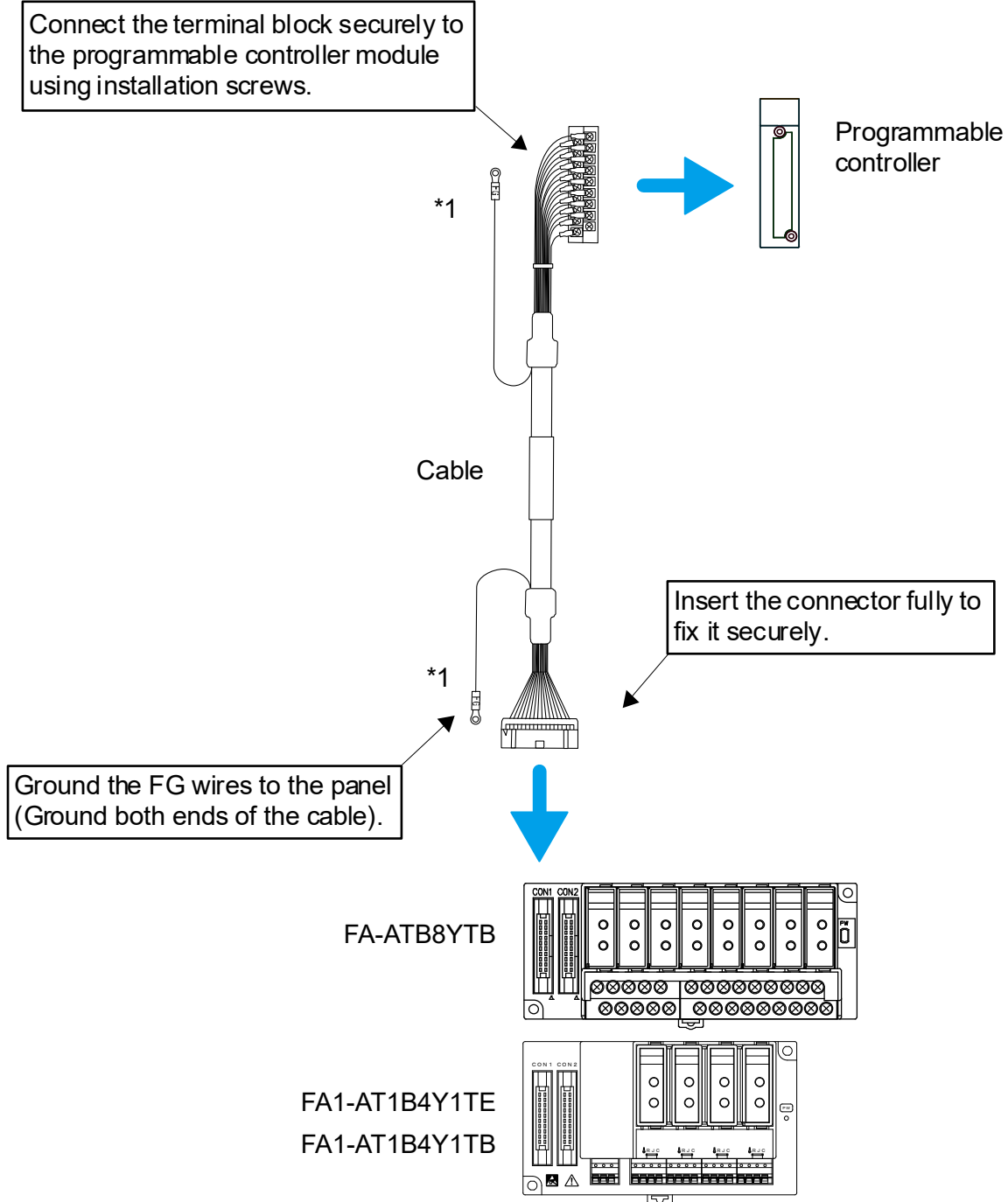

\*1: Ground the FG wires of the cable to the panel.

If the values retrieved by the programmable controller vary greatly due to noise, install a ferrite core (such as the ESD-SR-250 manufactured by TOKIN Corporation) on the unshielded part of the cable.

\*2: Instead of a 8-channel analog unit, two 4-channel bases can be used. To connect two bases, refer to 7-2.

7-1-2. When a terminal block to connector conversion adapter is used

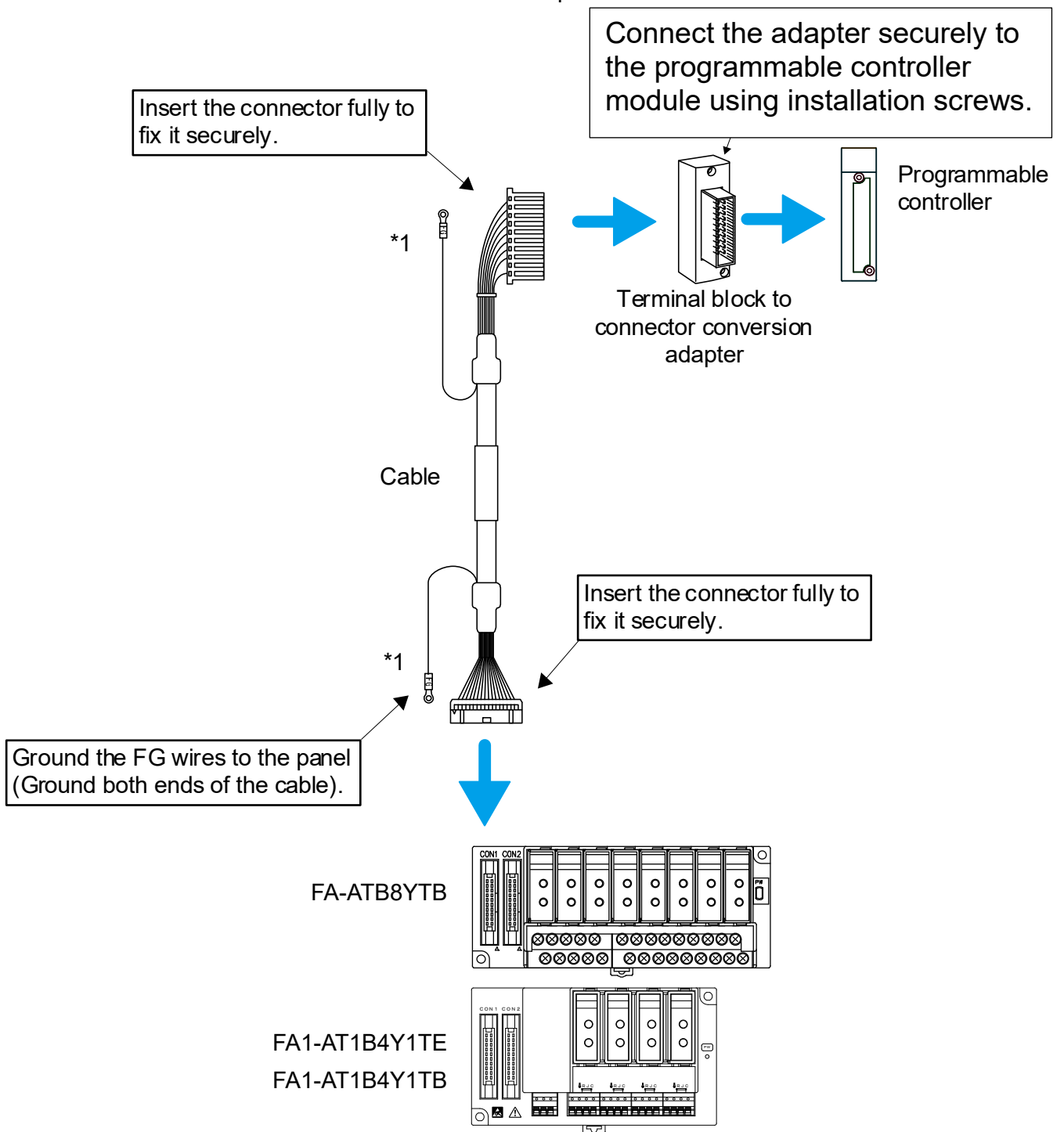

\*1: Ground the FG wires of the cable to the panel.

If the values retrieved by the programmable controller vary greatly due to noise, install a ferrite core (such as the ESD-SR-250 manufactured by TOKIN Corporation) on the unshielded part of the cable.

\*2: Instead of a 8-channel analog unit, two 4-channel bases can be used. To connect two bases, refer to 7-2.



7-1-3. When a discrete cable is used

CC-Link module, non-Mitsubishi programmable controller, or others

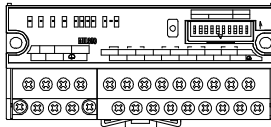

[FA-CBL\*\*ATYF pin assignment]

Signal name	Cable color	Dot	Dot color
CH1+	Pink	2	Black
CH1-		2	Red
CH2+	Yellow	2	Black
CH2-		2	Red
CH3+	White	2	Black
CH3-		2	Red
CH4+	Gray	2	Black
CH4-		2	Red
CH5+	Orange	2	Black
CH5-		2	Red
CH6+	Pink	1	Black
CH6-		1	Red
CH7+	Yellow	1	Black
CH7-		1	Red
CH8+	White	1	Black
CH8-		1	Red
24V	Gray	1	Black
24V		1	Red
24G	Orange	1	Black
24G		1	Red

Wire the cable securely to the terminal block of the programmable controller module.



Ground the FG wires to the panel.

Cable

\*1

Ground the FG wires to the panel.

Insert the connector fully to fix it securely.



FA-ATB8YTb

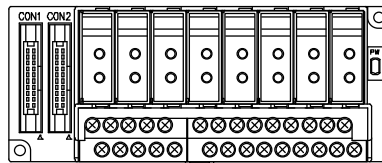

FA1-AT1B4Y1TE  
FA1-AT1B4Y1TB

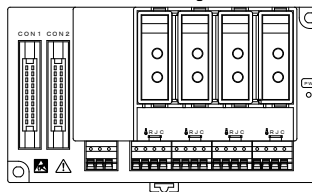

\*1: Ground the FG wires of the cable to the panel.

If the values retrieved by the programmable controller vary greatly due to noise, install a ferrite core (such as the ESD-SR-250 manufactured by TOKIN Corporation) on the unshielded part of the cable.

\*2: Instead of a 8-channel analog unit, two 4-channel bases can be used. To connect two bases, refer to 7-2.

## 7-2. Connection example when an additional 4-channel base is used

Connect the base as shown in the figure below.

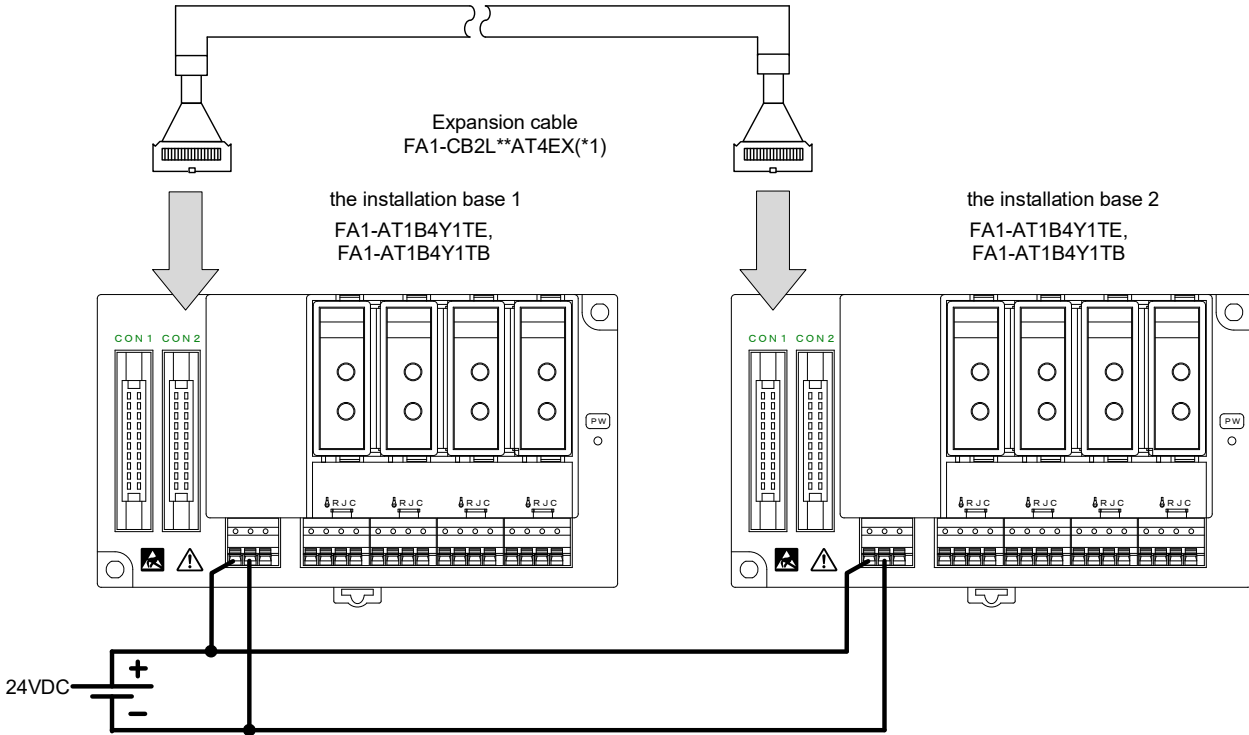

\*1: When the base is added, note that CH1 to CH4 and CH5 to CH8 change places with each other. (Refer to the following table.)

Monitor display

Order of channels displayed on the monitor		
When a 8-channel base is used	When a 4-channel base is used	When two 4-channel bases are used*1
CH1	CH1	CH5
CH2	CH2	CH6
CH3	CH3	CH7
CH4	CH4	CH8
CH5	—	CH1
CH6	—	CH2
CH7	—	CH3
CH8	—	CH4

\*1: When two 4-channel bases are used, channels of the added base are displayed first.

### 7-3. Mounting/removing a signal conversion module

(1) How to mount the module to the installation base

1) Align the signal conversion module with a slot of the installation base.

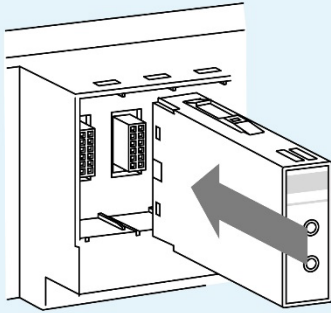

2) Insert the signal conversion module until the mounting/removing hooks are locked (until they click).

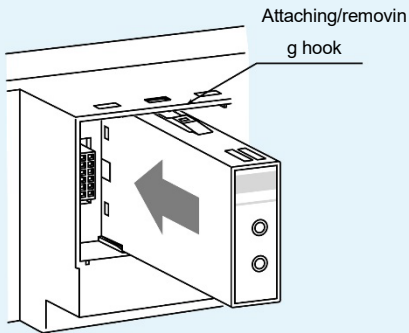

(2) How to remove the module from the installation base

1) Hold both sides of the mounting/removing hooks.

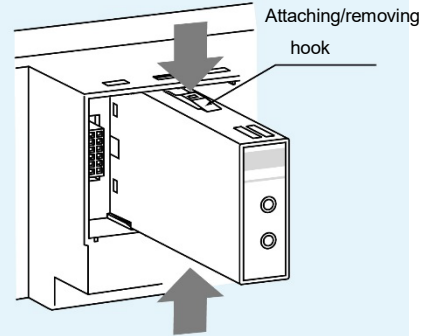

2) Pull out the signal conversion module while holding the hooks.

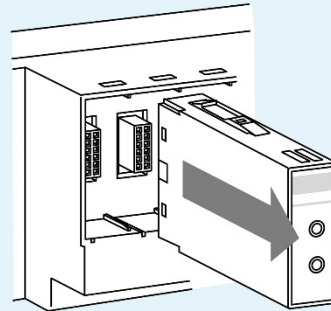

Note	
Use an output type signal conversion module (the one with a orange line). Using an input type signal conversion module (the one with an purple line) incorrectly may cause failure of the products.	

Points	
(1) Hold the installation base, not the signal conversion module, when transporting the installation base with the signal conversion module mounted or when installing it to a panel.	
(2) Mount a dummy module (FA-ATNDM) onto an empty slot of the installation base for dust prevention.	

## 7-4. Wiring to a spring clamp terminal block

### (1) Wires routing

#### (a) Fabrication on cable insulator

Strip the wire as follows. If the length of the sheath peeled is too long, a short circuit may occur with neighboring wires. If the length is too short, wires might come off. Wire the stripped cable after twisting it to prevent it from becoming loose. In addition, do not solder it.

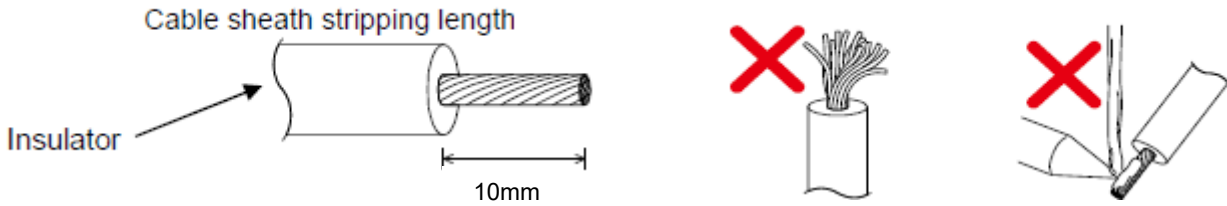

#### (b) Using a ferrule terminal

Insert wires to a ferrule terminal and crimp it. Make sure that core wire slightly comes out of the ferrule. Check the condition of the ferrule terminal after crimping. Do not use a ferrule terminal of which the crimping is inappropriate, or the face is damaged.

Refer to chapter 9 for the applicable ferrule terminal.

\* Ferrule terminals crimped onto one wire are applicable to the terminal block of this product.

If multiple wires need to be installed (such as for the power supply), provide an external common terminal. (For example, ABCOM of a high-speed counter module or COM of a simple motion module)

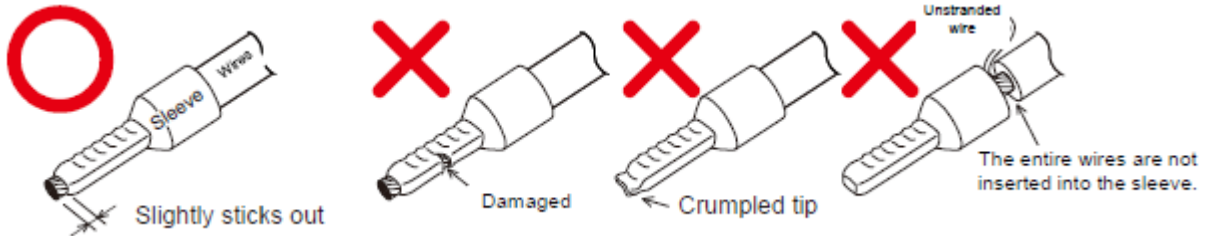

#### (c) Inserting wires

The wire with ferrule or solid cable can be inserted into the wire insertion hole. After inserting, pull the wire lightly to confirm that the wire is surely connected.

For the correct terminal insertion direction, refer to the figure below.

When binding twisted wires, press the push button using the screw driver, then insert the twisted wires into the wire insertion hole.

\* Make sure to insert the wire straight as far as it will go.

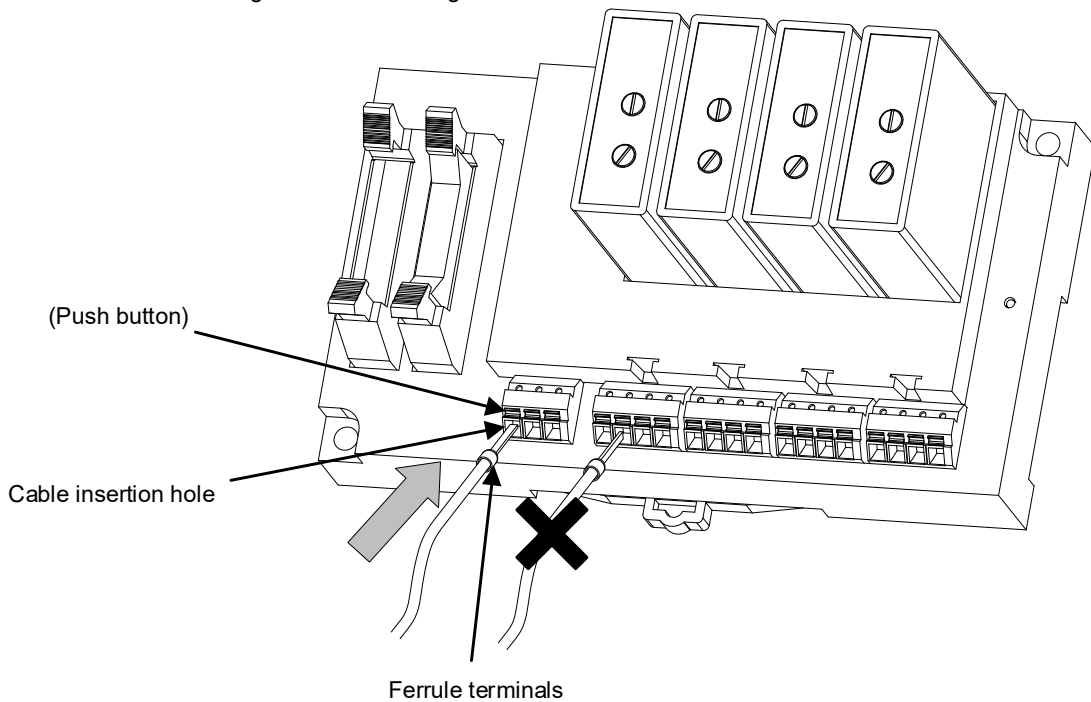

(2) Wires removal

Press the push button all the way using the screw driver, then pull out the wire.

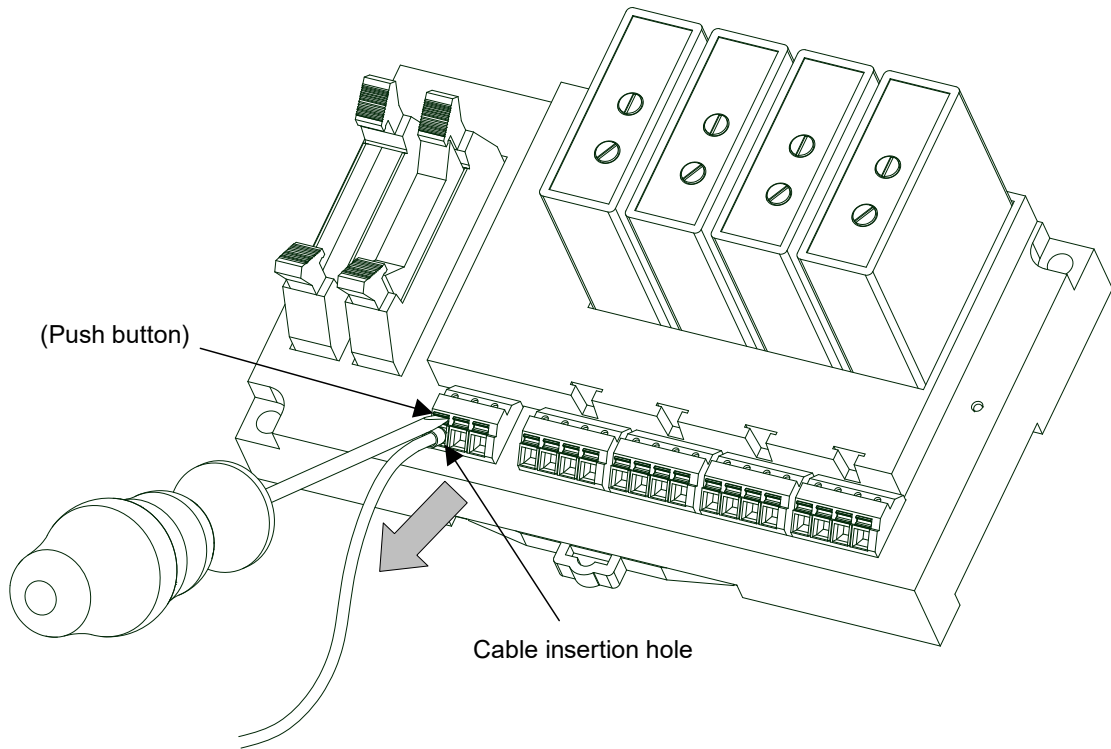

Use the screw driver shown in the table below.

Recommended tool (screw driver)		
Manufacturer	Model	Blade edge size
PHOENIX CONTACT	SZS 0,4×2,5 VDE	2.5x0.4mm

## 8. APPLICABLE SOLDERLESS TERMINALS

Type		Round		Y-shaped	
Manufacture	Applicable wire size	Non-insulated solderless terminal	Insulated solderless terminal	Non-insulated solderless terminal	Insulated solderless terminal
Nichifu Co., Ltd. NTM	0.3 to 1.25mm <sup>2</sup>	R1.25-3N R1.25-3.5N	TG <sub>N</sub> <sup>V</sup> 1.25-3N TG <sub>N</sub> <sup>V</sup> 1.25-3.5N	1.25Y-3 1.25Y-3N 1.25Y-3L 1.25Y-3.5	TG <sub>N</sub> <sup>V</sup> 1.25Y-3 TG <sub>N</sub> <sup>V</sup> 1.25Y-3N TG <sub>N</sub> <sup>V</sup> 1.25Y-3L TG <sub>N</sub> <sup>V</sup> 1.25Y-3.5
	1.25 to 2.0mm <sup>2</sup>	R2-3N	TG <sub>N</sub> <sup>V</sup> 2-3N	2Y-3 2Y-3.5S	TG <sub>N</sub> <sup>V</sup> 2Y-3 TG <sub>N</sub> <sup>V</sup> 2Y-3.5S
Japan Solderless Terminal Mfg. Co., Ltd. JST	0.3 to 1.25mm <sup>2</sup>	1.25-MS3	V1.25-MS3	1.25-B3A 1.25-C3A 1.25-N3A 1.25-C3.5A	V1.25-B3A V1.25-N3A
	1.25 to 2.0mm <sup>2</sup>	2-MS3	V2-MS3	2-N3A 2-M3A	V2-N3A
Nippon Tanshi Co., Ltd. NTK	0.3 to 1.25mm <sup>2</sup>	R1.25-3ML R1.25-3.5SL	RAV1.25-3ML RAP1.25-3ML	VD1.25-3L VD1.25-3.5SS VD1.25-3.5S	VDAV1.25-3L VDAV1.25-3.5SS VDAV1.25-3.5S
	1.25 to 2.0mm <sup>2</sup>	R2-3SL	RAV2-3SL RAP2-3SL	VD2-3S VD2-3.5SS VD2-3.5S	VDAV2-3.5SS VDAV2-3.5S

### • Solderless terminal dimensions

[Unit : mm]

Round non-insulated solderless terminal

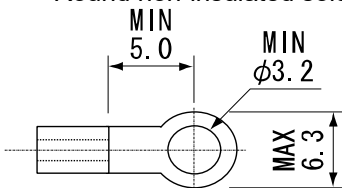

Round insulated solderless terminal

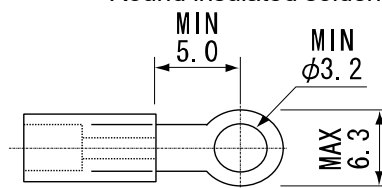

Y-shaped non-insulated solderless terminal

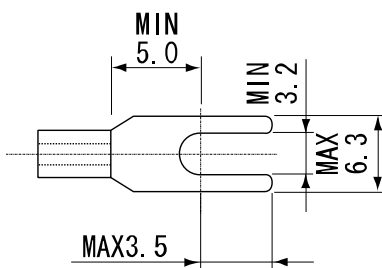

Y-shaped insulated solderless terminal

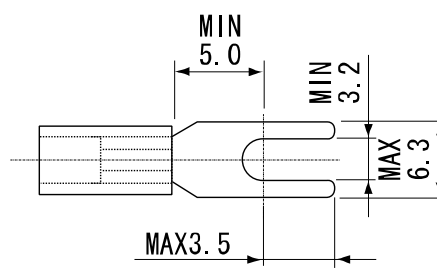

### • Terminal block shape

[Unit : mm]

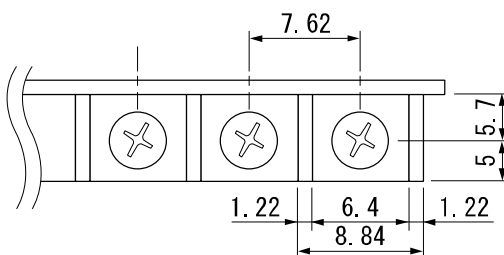

• Applicable solderless terminals (ferrule)

Type		Applicable ferrule	Crimp tool
Manufacturer	Applicable wire size		
PHOENIX CONTACT	0.25 mm <sup>2</sup> (AWG24)	AI 0,25-10 YE	CRIMPFOX 6
	0.34 mm <sup>2</sup> (AWG22)	AI 0,34-10 TQ	
	0.5 mm <sup>2</sup> (AWG20)	AI 0,5-10 WH	
	0.75 mm <sup>2</sup> (AWG18)	AI 0,75-10 GY	
	1.0 mm <sup>2</sup> (AWG18)	AI 1-10 RD	
	1.5 mm <sup>2</sup> (AWG16)	AI 1,5-10 BK	

## 9. PRECAUTIONS

- (1) Allow the product to warm up for 10 minutes or more as a precautionary measure though this product works at the same time as powering it on.
- (2) Since the signal conversion module had been calibrated at the factory, calibration at the site is not necessary. However, when the calibration is required for the conformity between the signal conversion module and other connected device, make the zero/span adjustment as follows:
  - (Trimmer operation... Turning to the right (in clockwise) for increasing a value,  
Turning to the left (in counterclockwise) for decreasing a value)
  - 1) Allow the product to warm up for 10 minutes or more after powering it on.
  - 2) Input the signal equivalent to 0% in the input range, and adjust output signal to 0% by using the zero adjustment trimmer.
  - 3) Input the signal equivalent to 100% in the input range, and adjust output signal to 100% by using the span adjustment trimmer.
  - 4) Complete the zero/span adjustment by repeating the operation in Step 2 and 3.
  - 5) Input the signal of 25%, 50%, and 75% in the input range, and check the output linearity
- (3) When the monitor output is used, the handling is different depending on the usage condition of the module. The following table lists the handling of each module.

Programmable controller analog output signal	Signal conversion module, Pass-through module		Installation base terminal block	Monitor output*1, *2
4 to 20mA	FA-ATS*M1Y*****		Output signals that differ depending on the signal conversion modules	1 to 5V
1 to 5V				1 to 5V
4 to 20mA	FA-ATFTMX Y	When signals are passed through	4 to 20mA	*3
1 to 5V		when current is converted to voltage	1 to 5V	1 to 5V
		When signals are passed through	1 to 5V	1 to 5V

\*1: For a measuring device connected to a monitor output, use a device with sufficiently large input resistance. (Input resistance of 1MΩ or more is recommended.)

\*2: Do not short across connector pins No.1 to 4 for monitor output of the installation base FA-ATB8YTB (output type) since the pins are assigned to 24V/24G.

\*3: The voltage value corresponding to the input resistance (R) of the connected external device is detected. The current value (I) can be calculated with the monitor output voltage (V) and the input resistance (R) by the following formula.

$$I = V / R$$

Example) When R (the input resistance of the connected external device) = 500Ω, and V (the measured voltage value) = 5V, the formula for I (the detected current) is as below.  
 $5V / 500\Omega = 10mA$

## 10. GRATIS WARRANTY TERMS AND GRATIS WARRANTY RANGE

If any fault or defect (hereinafter referred to as "Failure") attributable to Mitsubishi Electric Engineering should occur within the gratis warranty period, Mitsubishi Electric Engineering shall replace the product free of charge via the distributor from whom you made your purchase.

- Gratis warranty period

The gratis warranty period of this product shall be one (1) year from the date of purchase or delivery to the designated place.

- Gratis warranty range

- (1) The gratis warranty range shall be limited to normal use based on the usage conditions, methods and environment, etc., defined by the terms and precautions, etc., given in the instruction manual, user's manual, and caution labels on the product.
- (2) In the following cases, a repair fee shall be applied even if within the gratis warranty period.
  - 1) Failure resulting from inappropriate storage or handling, carelessness or negligence by the user, or Failure caused by the user's hardware or software design.
  - 2) Failure caused by unapproved modifications, etc., to the product by the user.
  - 3) Failure that could have been avoided if, when the Mitsubishi Electric Engineering product was assembled into the user's device, safeguards defined by legal regulations applicable to the user's device or functions or structures considered standard by the industry had been provided.
  - 4) Failure recognized as preventable if the consumed products specified in instruction manuals, etc., were normally maintained or replaced.
  - 5) Replacement of consumable parts (relays, etc.).
  - 6) Failure caused by external factors beyond anyone's control such as fires or abnormal voltage, and Failure caused by Force Majeure such as earthquakes, lightning, or wind and water damage.
  - 7) Failure caused by reasons unpredictable by scientific technology standards at the time of shipment from Mitsubishi Electric Engineering.
  - 8) Any other failure not attributable to Mitsubishi Electric Engineering or found by the user to not be attributable to Mitsubishi Electric Engineering.

## 11. REPAIRABLE PERIOD AFTER DISCONTINUATION OF PRODUCTION

- (1) The period in which product repair (fee applied) is available is seven (7) years after product discontinuation.  
Discontinuation of production shall be reported by the distributor.
- (2) Product supply (including spare parts) is not possible after production has been discontinued.

## 12. EXCLUSION FROM LIABILITY FOR OPPORTUNITY LOSS AND SECONDARY LOSS

Regardless of the gratis warranty period, Mitsubishi Electric Engineering shall not be liable for compensation for damages arising from causes not attributable to Mitsubishi Electric Engineering, opportunity losses or lost profits incurred by the user due to Failures of Mitsubishi Electric Engineering products, damages or secondary damages arising from special circumstances, whether foreseen or unforeseen by Mitsubishi Electric Engineering, compensation for accidents, compensation for damages to products other than Mitsubishi Electric Engineering products, or compensation for replacement work, readjustment of onsite machinery and equipment, startup test runs or other duties carried out by the user.

## 13. TRADEMARKS

MELSEC, MELSEC iQ-R, CC-Link, CC-Link IE, and CC-Link/LT are trademarks or registered trademarks of Mitsubishi Electric Corporation. Other company names and product names in the text are trademarks or registered trademarks of each company.  
In some cases, trademark symbols such as '™' or '®' are not specified in this manual.



## FOR SAFE OPERATIONS

- This product has been manufactured as a general-purpose part for general industries, and has not been designed or manufactured to be incorporated in a device or system used in purposes related to human life.
- Before using the product for special purposes such as nuclear power, electric power, aerospace, medicine or passenger movement vehicles, consult with Mitsubishi Electric Engineering.
- This product has been manufactured under strict quality control. However, when installing the product where major accidents or losses could occur if the product fails, install appropriate backup or failsafe functions in the system.

---

## **mitsubishi electric engineering company limited**

1-13-5 Kudankita, Chiyoda-ku, Tokyo, Japan 102-8404

---

Specifications subject to change without notice.

50D-FA9010-123-E

Published in May 2022