

MITSUBISHI ELECTRIC ENGINEERING

Analog Signal Converter (Input Type)

Model

FA1-AT1B8X1TE	FA-ATSVM1X*****
FA-ATB8XTB	FA1-AT1CT-1-6
FA1-AT1B4X1TE	FA-ATFTMXY
FA1-AT1B4X1TB	FA-Q6TCA
FA-ATKB8XTB	
FA-ATKAA8XM	

User's Manual

Time and Wire Saving Devices



SAFETY PRECAUTIONS

(Read these precautions before using the products.)

Before using the products, please read this manual and the relevant manuals carefully, and pay full attention to safety to handle the products correctly.

The precautions given in this manual are concerned with time and wire saving device only.

For the safety precautions of the programmable controller system, refer to the user's manual for the programmable controller used.

If the equipment is used in a manner not specified by the manufacturer, the protection provided by the equipment may be impaired.

If the product is used in a manner not specified in this manual, the protection provided by the equipment may be impaired.

In this manual, the safety precautions are classified into two levels: "⚠️WARNING" and "⚠️CAUTION".



WARNING

Indicates that incorrect handling may cause hazardous conditions, resulting in death or severe injury.



CAUTION

Indicates that incorrect handling may cause hazardous conditions, resulting in minor or moderate injury or property damage.

Under some circumstances, failure to observe the precautions given under "⚠️CAUTION" may lead to serious consequences.

Observe the precautions of both levels because they are important for personal and system safety.

Make sure that the end users read this manual and then keep the manual in a safe place for future reference.

[Design Precautions]



WARNING

- Configure safety circuits externally to ensure that the entire system operates safely even when a fault occurs in the external power supply, the programmable controller, or the products. Failure to do so may result in an accident due to an incorrect output or malfunction.
 - (1) Emergency stop circuits, protection circuits, and protective interlock circuits for conflicting operations (such as forward/reverse rotations or upper/lower limit positioning) must be configured externally.
 - (2) Outputs may remain on or off due to a failure of a component such as a relay, transistor, and triac used for digital signal converter outputs. Configure an external circuit for monitoring output signals that could cause a serious accident.
- In an output circuit for digital signal converter outputs, when a load current exceeding the rated current or an overcurrent caused by a load short-circuit flows for a long time, it may cause smoke and fire. To prevent this, configure an external safety circuit, such as a fuse.
- Configure a circuit so that the programmable controller is turned on first and then the external power supply. If the external power supply is turned on first, an accident may occur due to an incorrect output or malfunction.

[Design Precautions]



CAUTION

- Do not install the control lines or communication cables together with the main circuit lines or power cables. Keep a distance of 100mm (3.94 inches) or more between them. Failure to do so may result in malfunction or failure due to noise.
- When using a terminal block conversion module for a high-speed counter module, do not install the control lines or communication cables together with the main circuit lines or power cables. Keep a distance of 150mm (5.91 inches) or more between them. Failure to do so may result in malfunction or failure due to noise.
- Keep a distance of 100mm (3.94 inches) or more between a thermocouple or RTD (Resistance Temperature Detector) and the main circuit line or AC control lines. Also, keep the thermocouple or RTD away from a circuit that includes harmonics, such as a high-voltage circuit and a load circuit of an inverter. If not, the thermocouple or RTD is more likely to be affected by noise, surges, and induction.
- At power-on or power-off, a voltage may occur or a current may flow between output terminals for a moment. To use an analog signal converter or analog terminal block conversion module, start the control after analog outputs become stable.
- Do not place an analog signal converter or analog terminal block conversion module near a device that generates magnetic noise.
- When a device such as a lamp, heater, or solenoid valve is controlled using a module for digital signal converter outputs, a large current (approximately 10 times greater than normal) may flow when the output is turned from off to on. Therefore, select a module for digital signal converter outputs that has a sufficient current rating.

[Installation Precautions]



WARNING

- Shut off the external power supply (all phases) used in the system before installation. Failure to do so may result in electric shock or damage to the products.

[Installation Precautions]



CAUTION

- Use products in an environment that meets the general specifications in this manual. Failure to do so may result in electric shock, fire, malfunction, or damage to or deterioration of the products.
- Securely fix the products with a DIN rail or screws. Incorrect installation may cause malfunction, failure, or drop of the module. When using the products in an environment of frequent vibrations, fix the products with screws.
- Tighten the screws within the specified torque range. Undertightening can cause drop of the screw, short circuit, or malfunction. Overtightening can damage the screw and/or products, resulting in drop, short circuit, or malfunction.
- Attach DIN rail stoppers on the right and left sides of the spring clamp conversion module to fix the module securely.
- Shut off the external power supply (all phases) used in the system before mounting or removing the products. Failure to do so may result in damage to, malfunction of, or failure of the products.
- Do not directly touch any conductive parts and electronic components of the products. Failure to do so may cause malfunction or failure of the products.
- Install the products in the correct orientation if it is specified. Failure to do so may result in damage to or deterioration of the products.
- When drilling screw holes, be careful not to drop chips into the inside of the products or conductive parts. Such foreign matter can cause a fire, failure, or malfunction.
- When using modules for replacing digital signal converters or signal converters modules, use them correct combination. Incorrect combination may cause failure.
- Shut off the power supply before installing/removing a module for replacing digital signal converters. Failure to do so may cause failure or malfunction.
- Securely mount a module for replacing digital signal converters and signal conversion module on a digital signal converter and installation base. Failure to do so may cause damage to or drop of the products, or malfunction due to poor contact. Follow the correct procedure to install/remove them. Failure to do may cause damage to or drop of the products, or malfunction due to poor contact.
- When a module for digital signal converters or signal conversion module is mounted on a digital signal converter or installation base, hold the digital signal converter or installation base to transport them or install them to a panel. Holding the module for digital signal converters or signal conversion module may cause drop or failure of the digital signal converter or installation base.

[Wiring Precautions]



WARNING

- Shut off the external power supply (all phases) used in the system before wiring. Failure to do so may result in electric shock or damage to the products.
- After wiring, attach the included terminal cover to the products before turning them on for operation. Failure to do so may result in electric shock.
- Use copper conductors only a temperature rating of 75°C or more.

[Wiring Precautions]



CAUTION

- Use applicable solderless terminals and tighten them within the specified torque range. Failure to do so may cause failure, damage, or malfunction.
- Check the rated voltage and terminal layout before wiring to the products, and connect the cables correctly. Connecting a power supply with a different voltage rating or incorrect wiring may cause a fire or failure.
- Do not install the control lines or communication cables together with the main circuit lines or power cables. Keep a distance of 100mm or more between them. Failure to do so may result in malfunction due to noise.
- When using a terminal block conversion module for a high-speed counter module, do not install the control lines or communication cables together with the main circuit lines or power cables. Keep a distance of 150mm (5.91 inches) or more between them. Failure to do so may result in malfunction or failure due to noise.
- Keep a distance of 100mm (3.94 inches) or more between a thermocouple or RTD (Resistance Temperature Detector) and the main circuit line or AC control lines. Also, keep the thermocouple or RTD away from a circuit that includes harmonics, such as a high-voltage circuit and a load circuit of an inverter. If not, the thermocouple or RTD is more likely to be affected by noise, surges, and induction.
- Do not place an analog signal converter or analog terminal block conversion module near a device that generates magnetic noise.
- Place the cables in a duct or clamp them. If not, dangling cable may swing or inadvertently be pulled, resulting in damage to the products or cables or malfunction due to poor contact.
- Tighten the terminal screws within the specified torque range. Under tightening can cause short circuit, fire, or malfunction. Overtightening can damage the screw and/or products, resulting in drop, short circuit, or malfunction.
- Tighten the connector screws within the specified torque range. Under tightening can cause short circuit, fire, or malfunction. Overtightening can damage the screw and/or products, resulting in drop, short circuit, fire, or malfunction.
- Securely connect connectors to the products. Failure to do so may cause malfunction.
- When disconnecting a cable from the products, do not pull the cable by the cable part. For the cable with connector, hold the connector part of the cable. For the cable connected to the terminal block, loosen the terminal screw. Pulling the cable connected to the products may result in malfunction or damage to the products or cable.
- Check the interface type and correctly connect the cable. Incorrect wiring (connecting the cable to an incorrect interface) may cause failure of the products and external device.
- Prevent foreign matter such as dust or wire chips from entering the products. Such foreign matter can cause a fire, failure, or malfunction.
- The products must be installed in control panels. Connect the main power supply to the products in the control panel through a relay terminal block. Wiring and replacement of the products must be performed by qualified maintenance personnel with knowledge of protection against electric shock.
- When connecting the products with a programmable controller, check that the product configuration is correct. An incorrect configuration may cause failure or malfunction.
- Use the products with no force applied to their connectors. Applied force may cause failure or disconnection.
- Attach protective covers or signal conversion modules to unused connectors or empty slots of the products. Failure to do so may cause a fire, failure, or malfunction due to foreign matter.
- When using modules for replacing digital signal converters or signal conversion modules, use them in the correct combination. Incorrect combination may cause failure of a programmable controller, digital signal converter, installation base, or external device.
- Securely mount modules for replacing digital signal converters and signal conversion modules on a digital signal converter and installation base. Failure to do so may cause damage to or drop of the products, or malfunction due to poor contact. Follow the correct procedure to install/remove them. Failure to do so may cause damage to or drop of the products, or malfunction due to poor contact.
- Individually ground the FG terminal of the products with a ground resistance of 100 ohms or less. Failure to do so may result in electric shock or malfunction.

[Startup and Maintenance Precautions]



WARNING

- Do not touch any terminal while power is on. Doing so will cause electric shock or malfunction.
- Shut off the external power supply (all phases) used in the system before cleaning the products or retightening the terminal screws, connector screws, or products fixing screws. Failure to do so may result in electric shock or cause failure or malfunction of the products. Undertightening can cause drop of the screw, short circuit, or malfunction. Overtightening can damage the screw and/or products, resulting in drop, short circuit, or malfunction.

[Startup and Maintenance Precautions]



- Do not disassemble or modify the products. Doing so may cause failure, malfunction, injury, or a fire.
- Use any radio communication device such as a cellular phone or PHS (Personal Handy-phone System) more than 25cm away in all directions from the programmable controller and products. Failure to do so may cause malfunction.
- Shut off the external power supply (all phases) used in the system before mounting or removing the products. Failure to do so may cause failure or malfunction of or damage to the products.
- After the first use of the products, do not connect/remove the products and cables more than 50 times (IEC 61131-2 compliant). Exceeding the limit may cause malfunction.
- Startup and maintenance of a control panel must be performed by qualified maintenance personnel with knowledge of protection against electric shock. Lock the control panel so that only qualified maintenance personnel can operate it.
- Before handling the products, touch a conducting object such as a grounded metal to discharge the static electricity from the human body. Failure to do so may cause failure or malfunction of the products.
- The ESD susceptibility symbol shown below is placed on the products. This symbol products is susceptible static electricity passed. Before handling the connector, touch a conducting object such as a grounded metal to release the static electricity from your body. Failure to do so may cause the products to fail or malfunction. Do not touch the connector when the products is powered. Doing so may result in injury or cause the products to malfunction due to the static electricity in your body.



[Disposal Precautions]



- When disposing of the products, treat them as industrial waste.

[Transportation Precautions]



- Do not apply shock that exceeds the shock resistance described in the general specifications during transportation since the products are precision devices. Doing so may cause failure of the module.
- The halogens (such as fluorine, chlorine, bromine, and iodine), which are contained in a fumigant used for disinfection and pest control of wood packaging materials, may cause failure of the products. Prevent the entry of fumigant residues into the product or consider other methods (such as heat treatment) instead of fumigation. The disinfection and pest control measures must be applied to unprocessed raw wood.

CONDITIONS OF USE FOR THE PRODUCT

- (1) This Mitsubishi Electric Engineering Company Limited (hereinafter "MEE") product ("the PRODUCT") shall be used in conditions:
- i) where any problems, faults, or failures occurring in the PRODUCT, if any, shall not lead to any major or serious accident; and
 - ii) where the backup and fail-safe functions are systematically or automatically provided outside of the PRODUCT in case of any problems, faults, or failures occurring in the PRODUCT.
- (2) The PRODUCT has been designed and manufactured for the purpose of being used in general industries. MEE SHALL HAVE NO RESPONSIBILITY OR LIABILITY (INCLUDING, BUT NOT LIMITED TO ANY AND ALL RESPONSIBILITY OR LIABILITY BASED ON CONTRACT, WARRANTY, TORT, PRODUCT LIABILITY) FOR ANY INJURY OR DEATH TO PERSONS OR LOSS OR DAMAGE TO PROPERTY CAUSED BY the PRODUCT THAT ARE OPERATED OR USED IN APPLICATION NOT INTENDED OR EXCLUDED BY INSTRUCTIONS, PRECAUTIONS, OR WARNING CONTAINED IN MEE USER'S, INSTRUCTION AND/OR SAFETY MANUALS, TECHNICAL BULLETINS AND GUIDELINES FOR the PRODUCT. ("Prohibited Application") Prohibited Applications include, but not limited to, the use of the PRODUCT in:
- Nuclear Power Plants and any other power plants operated by Power companies, and/or any other cases in which the public could be affected if any problems or faults occurs in the PRODUCT.
 - Railway companies or Public service purposes, and/or any other cases in which establishment of a special quality assurance system is required by the Purchaser or End User.
 - Aircraft or Aerospace, Medical applications, Train equipment, transport equipment such as Elevator and Escalator, Incineration and Fuel devices, Vehicles, Manned transportation, Equipment for Recreation and Amusement, and Safety devices, handling of Nuclear or Hazardous Materials or Chemicals, Mining and Drilling, and/or other applications where there is a significant risk of injury to the public or property.
- Notwithstanding the above restrictions, MEE may in its sole discretion, authorize use of the PRODUCT in one or more of the Prohibited Applications, provided that the usage of the PRODUCT is limited only for the specific applications agreed to by MEE and provided further that no special quality assurance or fail-safe, redundant or other safety features which exceed the general specifications of the PRODUCTS are required. For details, please contact the MEE representative in your region.
- (3) MEE shall have no responsibility or liability for any problems involving the PRODUCT trouble and system trouble caused by DoS attacks, unauthorized access, computer viruses, and other cyberattacks.

EMC and Low Voltage Directives

Compliance with the EMC Directive, which is one of the EU directives, has been mandatory for products sold within EU member states since 1996 as well as compliance with the Low Voltage Directive since 1997.

For products compliant to the EMC and Low Voltage Directives, their manufacturers are required to declare compliance and affix the CE marking.

In some other countries and regions, manufacturers are required to make their products compliant with applicable laws or regulations and attach a certification mark on the products as well (such as UK Conformity Assessed (UKCA) marking in the UK, and Korea Certification (KC) marking in South Korea).

(1) Sales representative in EU member states

The sales representative in EU member states is:

Company: MITSUBISHI ELECTRIC EUROPE B.V.

Address: Mitsubishi-Electric-Platz 1, 40882 Ratingen, Germany

(2) Method of ensuring compliance

To ensure that products maintain EMC and Low Voltage Directives when incorporated into other machinery or equipment, certain measures may be necessary. Please refer to "EMC and Low Voltage Directives Compliant Manual" (50D-FA9010-108).

REVISIONS

*The manual number is given on the bottom left of the last page.

Print Date	*Manual Number	Revision
January, 2013	50D-FA9010-122	First edition
March, 2013	50D-FA9010-122-A	<u>Added or modified parts</u> 3. PERFORMANCE SPECIFICATIONS, 5. INSTALLATION ORIENTATION
March, 2014	50D-FA9010-122-B	<u>Added or modified parts</u> Product addition: FA-ATKATB8XTB, FA-ATKAA8XM, FA-ATSVM1XTK0040/60/80, FA-ATSVM1XRPT0010/20, SAFETY PRECAUTIONS, EMC and Low Voltage Directives, Table of contents, 2. GENERAL SPECIFICATIONS, 3. PERFORMANCE SPECIFICATIONS, 10. PRECAUTIONS, 11. GRATIS WARRANTY TERMS AND GRATIS WARRANTY RANGE, 12. REPAIR PERIOD AFTER DISCONTINUATION OF PRODUCTION (FEE APPLIED), 13. EXCLUSION OF OPPORTUNITY LOSS AND SECONDARY LOSS FROM WARRANTY LIABILITY
May, 2015	50D-FA9010-122-C	<u>Added or modified parts</u> 8. CONNECTABLE MODULES AND CABLES
March, 2018	50D-FA9010-122-D	<u>Added or modified parts</u> Product addition: FA-Q6TCA, SAFETY PRECAUTIONS, EMC and Low Voltage Directives, REVISIONS, 3. PERFORMANCE SPECIFICATIONS, 4. CONNECTABLE MODULES AND CABLES, 5. EXTERNAL DIMENSIONS, 6. INSTALLATION ORIENTATION, 7. CONNECTING METHOD, 14. TRADEMARKS
November, 2020	50D-FA9010-122-E	<u>Added or modified parts</u> 7. CONNECTING METHOD
November, 2021	50D-FA9010-122-F	<u>Added or modified parts</u> Product addition : FA1-AT1B4X1TE, FA1-AT1B4X1TB SAFETY PRECAUTIONS, Table of contents, 1. INTRODUCTION, 3. PERFORMANCE SPECIFICATIONS, 4. CONNECTABLE MODULES AND CABLES, 5. EXTERNAL DIMENSIONS, 6. INSTALLATION ORIENTATION, 7. CONNECTING METHOD, 8. EXTERNAL CONNECTION, 9. APPLICABLE SOLDERLESS TERMINALS AND FERRULE
November, 2023	50D-FA9010-122-G	<u>Added or modified parts</u> Product addition : FA1-AT1B8X1TE Table of contents, 1. INTRODUCTION, 2. GENERAL SPECIFICATIONS, 3. PERFORMANCE SPECIFICATIONS, 4. CONNECTABLE MODULES AND CABLES, 5. EXTERNAL DIMENSIONS, 6. INSTALLATION ORIENTATION, 7. CONNECTING METHOD, 8. EXTERNAL CONNECTION
October, 2025	50D-FA9010-122-H	<u>Added or modified parts</u> Product addition : FA1-AT1CT-1-6 SAFETY PRECAUTIONS, CONDITIONS OF USE FOR THE PRODUCT, Table of contents, 1. INTRODUCTION, 3. PERFORMANCE SPECIFICATIONS, 4. CONNECTABLE MODULES AND CABLES, 5. EXTERNAL DIMENSIONS, 7. CONNECTING METHOD, 8. EXTERNAL CONNECTION, 11. WARRANTY

This manual confers no industrial property rights or any rights of any other kind, nor does it confer any patent licenses. Mitsubishi Electric Engineering cannot be held responsible for any problems involving industrial property rights which may occur as a result of using the contents noted in this manual.

© 2013 (2025) MITSUBISHI ELECTRIC ENGINEERING COMPANY LIMITED ALL RIGHTS RESERVED

CONTENTS

SAFETY PRECAUTIONS	2
CONDITIONS OF USE FOR THE PRODUCT	7
EMC and Low Voltage Directives	8
REVISIONS	9
CONTENTS	10
1. INTRODUCTION	11
2. GENERAL SPECIFICATIONS	11
3. PERFORMANCE SPECIFICATIONS	12
3-1. Input type 8-channel installation base, spring clamp terminal block type (FA1-AT1B8X1TE).....	12
3-2. Input type 8-channel installation base, screw terminal block type (FA-ATB8XTB).....	13
3-3. Input type 4-channel installation base, spring clamp terminal block type (FA1-AT1B4X1TE).....	14
3-4. Input type 4-channel installation base, terminal block type (FA1-AT1B4X1TB).....	15
3-5. Input type installation base with connector for adapter (FA-ATKB8XTB).....	16
3-6. Conversion adapter current connection (two outputs) (FA-ATKAA8XM).....	17
3-7. Voltage input signal conversion module (FA-ATSVM1XV****).....	18
3-8. Current input signal conversion module (FA-ATSVM1XA420).....	19
3-9. Distributor signal conversion module (2-wire transmitter) (FA-ATSVM1XD).....	20
3-10. Thermocouple temperature input signal conversion module (FA-ATSVM1XT*).....	21
3-11. RTD input signal conversion module (FA-ATSVM1XR***).....	23
3-12. CT input signal conversion module (FA1-AT1CT-1-6).....	24
3-13. Pass-through module (FA-ATFTMX).....	26
3-14. Terminal block ↔ connector conversion adapter (FA-Q6TCA).....	26
4. CONNECTABLE MODULES AND CABLES	27
5. EXTERNAL DIMENSIONS	29
5-1. Input type 8-channel installation base, spring clamp terminal block type (FA1-AT1B8X1TE).....	29
5-2. Input type 8-channel installation base, screw terminal block type (FA-ATB8XTB).....	29
5-3. Input type 4-channel installation base, spring clamp terminal block type (FA1-AT1B4X1TE).....	30
5-4. Input type 4-channel installation base, terminal block type (FA1-AT1B4X1TB).....	30
5-5. Input type installation base with connector for adapter (FA-ATKB8XTB).....	31
5-6. Signal conversion module (FA-ATSVM1X****), pass-through module (FA-ATFTMX).....	32
5-7. Signal conversion module (FA1-AT1CT-1-6).....	32
5-8. Terminal block ↔ connector conversion adapter (FA-Q6TCA).....	32
6. INSTALLATION ORIENTATION	34
6-1. Input type 8-channel installation base, spring clamp terminal block type (FA1-AT1B8X1TE).....	34
6-2. Input type 8-channel installation base, screw terminal block type (FA-ATB8XTB).....	34
6-3. Input type 4-channel installation base, spring clamp terminal block type (FA1-AT1B4X1TE).....	35
6-4. Input type 4-channel installation base, terminal block type (FA1-AT1B4X1TB).....	35
6-5. Input type installation base with connector for adapter (FA-ATKB8XTB).....	36
7. CONNECTING METHOD	37
7-1. Installing the base unit.....	37
7-1-1. Installation using a DIN rail.....	37
7-1-2. Installation using screws.....	38
7-2. Connection example with a terminal block module of a programmable controller.....	40
7-2-1. When a cable with a terminal block is used.....	40
7-2-2. When a terminal block to connector conversion adapter is used.....	41
7-2-3. When a discrete cable is used.....	42
7-3. Connection example when an additional 4-channel base is used.....	43
7-4. Mounting/removing a signal conversion module.....	44
7-5. Mounting/removing a conversion adapter (FA-ATKB8XTB).....	44
7-6. Wiring to a spring clamp terminal block.....	45
8. EXTERNAL CONNECTION	48
9. APPLICABLE SOLDERLESS TERMINALS	50
10. PERCAUTIONS	52
11. WARRANTY	53
12. TRADEMARKS	54

1. INTRODUCTION

This manual describes the specifications and handling of the analog signal converter, which consists of the installation base (FA1-AT1B8X1TE, FA-ATB8XTB, FA1-AT1B4X1TE, FA1-AT1B4X1TB, FA-ATKB8XTB), the conversion adapter (FA-ATKAA8XM), the signal conversion module (FA-ATSVM1X****, FA1-AT1CT-1-6) and/or the I/O signal pass-through module (FA-ATFTMX), and the terminal block ↔ connector conversion adapter (FA-Q6TCA).

The analog signal converter includes the conversion adapter and the signal conversion module mounted to the installation base. The analog signal converter insulates analog input signals from a sensor or other devices between input and output terminals, and among the channels, converts them to the predefined signals, and outputs the converted signals.

2. GENERAL SPECIFICATIONS

Item		Specifications	
Operating surrounding air temperature		0 to 55°C	
Storage ambient temperature		-25 to 75°C	
Operating ambient humidity		5 to 95% RH, non-condensing	
Storage ambient humidity		5 to 95% RH, non-condensing	
Vibration resistance	Compliance with standard	JIS B 3502, IEC 61131-2	
	Under intermittent vibration	5 to 8.4Hz	Half amplitude: 3.5mm
		8.4 to 150Hz	Constant acceleration: 9.8m/s ² (1G)
		Sweep count	10 times each in X, Y, and Z directions
	Under continuous vibration	5 to 8.4Hz	Half amplitude: 1.75mm
		8.4 to 150Hz	Constant acceleration: 4.9m/s ² (0.5G)
Sweep count		—	
Shock resistance		Compliant with JIS B 3502 and IEC61131-2 (147m/s ² (15G), 3 times each in X, Y, and Z directions)	
Operating atmosphere		No corrosive gas	
Operating altitude *1		2,000m or lower	
Installation location		Inside the control panel *4, Indoor use	
Overvoltage category *2		II or lower	
Pollution level *3		2 or lower	

*1 : Do not use or store the module under the atmospheric pressure greater than that at an altitude of 0m.

*2 : Indicates the section of the power supply to which the equipment is assumed to be connected, between the public power grid and the machinery within the premises.

*3 : This is a guideline indicating the degree of the generation of conducting substances in the environment in which a device is used.

*4 : The enclosure is suitably designed for those specific environmental conditions, as applicable, and enclosure rate meets IP20 and minimum type 1 of UL 50.

3. PERFORMANCE SPECIFICATIONS

3-1. Input type 8-channel installation base, spring clamp terminal block type (FA1-AT1B8X1TE)

Item	Model	FA1-AT1B8X1TE ²
Number of slots ¹		8
Terminal block	Terminal block screw	M3 screw, 7.62mm pitch, spring-up screw with finger protector cover Tightening torque range: 58.8 to 88.2N·cm (6 to 9kgf·cm, 5.22 to 7.5lbf·in), UL standard conformity tightening torque: 59N·cm, 5.22lbf·in
	Applicable wire	22 to 14 AWG: 0.3 to 2.0mm ² (when solderless terminals are used)
Installation method	Screw	M4 × 0.7mm × 27mm or more Tightening torque range: 78 to 118N·cm (8 to 12kgf·cm, 7 to 10lbf·in)
	DIN rail	Applicable DIN rail: TH35-7.5Fe, TH35-7.5Al (compliant with IEC 60715)
External power supply ³		24VDC±10% (ripple ratio: within 5%, SELV and LIM or CLASS 2)
Current consumption (24VDC)		12mA or less (not including current consumption of the signal conversion module)
Withstand voltage, insulation resistance		750VAC for 1 minute, 10MΩ or higher between input/output/power supply
Weight		Approx. 250g

*1: Mount a dummy module (FA-ATNDM) onto an unused slot.

*2: When connecting a cable to the installation base, push the cable connector until it is locked. Failure to do so may cause poor contact.

*3: External connection to 24VDC power supply circuit of Analog Signal Converter must be powered from source compliant with SELV (Safety Extra-Low Voltage) and LIM (Limited energy circuit) according to UL 61010-2-201 or Class2 power supply.

●Block diagram

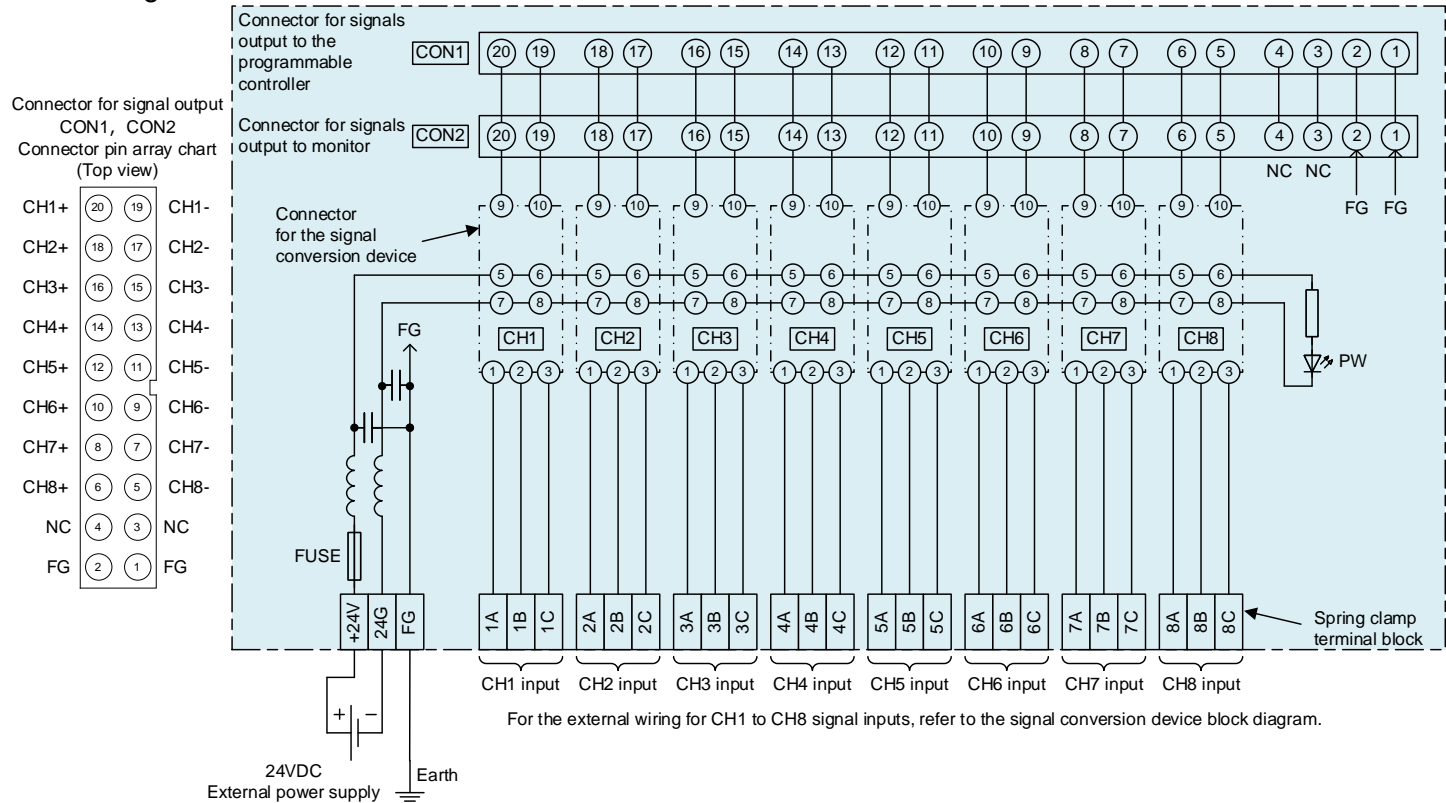

Notes:

- For a device connected to a monitor output, use a device with sufficiently large input resistance. (1MΩ or more is recommended.)
- The monitor output signal voltage differs depending on the output signal of the mounted module.
- Use shielded cables for external wirings.
- Use an input signal conversion device. Using an output signal conversion device incorrectly may damage the product.

3-2. Input type 8-channel installation base, screw terminal block type (FA-ATB8XTB)

Item	Model	FA-ATB8XTB ²
Number of slots ^{*1}		8
Terminal block	Terminal block screw	M3 screw, 7.62mm pitch, spring-up screw with finger protector cover Tightening torque range: 58.8 to 88.2N·cm (6 to 9kgf·cm, 5.22 to 7.5lbf·in), UL standard conformity tightening torque: 59N·cm, 5.22lbf·in
	Applicable wire	22 to 14 AWG: 0.3 to 2.0mm ² (when solderless terminals are used)
Installation method	Screw	M4 × 0.7mm × 20mm or more Tightening torque range: 78 to 118N·cm (8 to 12kgf·cm, 7 to 10lbf·in)
	DIN rail	Applicable DIN rail: TH35-7.5Fe, TH35-7.5Al (compliant with IEC 60715)
External power supply		24VDC±10%
Current consumption (24VDC)		6mA or less (not including current consumption of the signal conversion module)
Withstand voltage, insulation resistance		750VAC for 1 minute, 10MΩ or higher between input/output/power supply
Weight		Approx. 320g

*1: Mount a dummy module (FA-ATNDM) onto an unused slot.

*2: When connecting a cable to the installation base, push the cable connector until it is locked. Failure to do so may cause poor contact.

●Block diagram

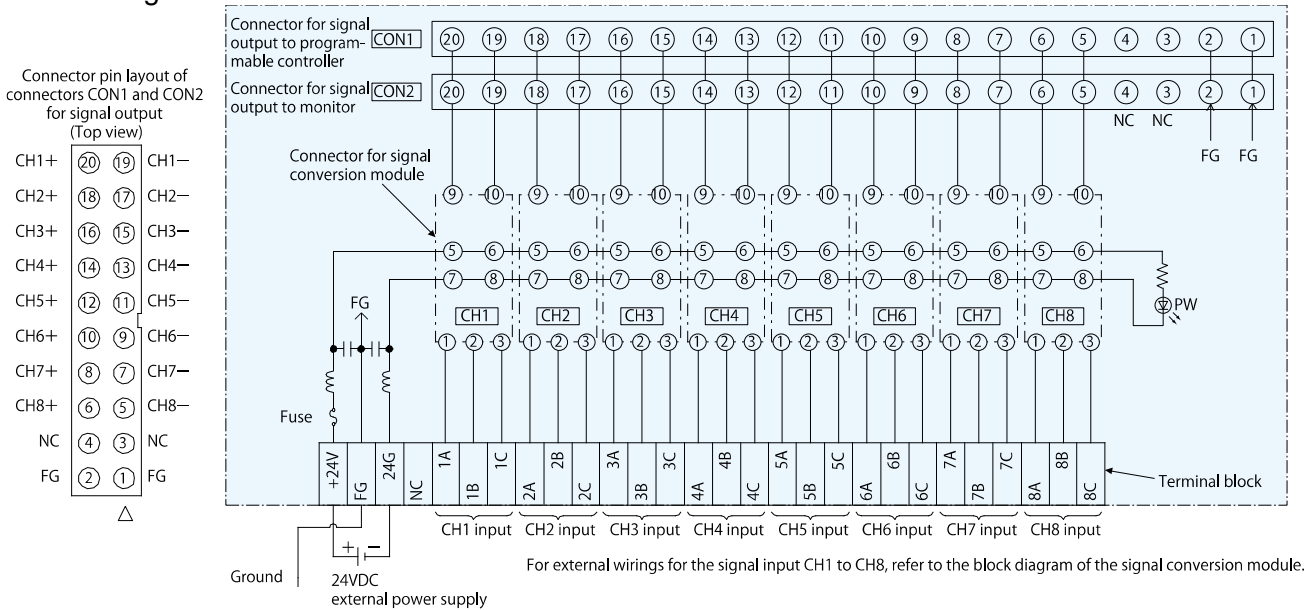

Notes:

- For a device connected to a monitor output, use a device with sufficiently large input resistance. (1MΩ or more is recommended.)
- The monitor output signal voltage differs depending on the output signal of the mounted module.
- Use shielded cables for external wirings.
- Use an input signal conversion device. Using an output signal conversion device incorrectly may damage the product.

3-3. Input type 4-channel installation base, spring clamp terminal block type (FA1-AT1B4X1TE)

Item		Model name	FA1-AT1B4X1TE ²
Number of slots ^{*1}			4
Terminal block	Applicable wire	When a ferrule is not used (stranded wire or solid wire)	0.2 to 1.5mm ² (24 to 16 AWG), Copper wire with a temperature rating of 75°C or more
		When a ferrule is used (stranded wire)	0.25 to 1.5mm ² (24 to 16 AWG), Copper wire with a temperature rating of 75°C or more
Wire strip length			10mm
Module mounting	Mounting screws		M4 × 0.7mm × 20mm or greater Tightening torque range: 78 to 118N·cm (8 to 12kgf·cm)
	DIN rail		Applicable DIN rail: TH35-7.5Fe, TH35-7.5Al (compliant with IEC 60715)
External supply power ^{*3}			24VDC±10% (ripple ratio: within 5%, SELV and LIM or CLASS 2)
Current consumption (24VDC)			6mA or less (not including current consumption by the conversion device, the Signal through device, the programmable controller, and the monitor equipment)
Withstand voltage/insulation resistance			Between input/output/power supply: 500VAC for 1 minute, 10MΩ or more
Weight			About 160g

*1: Mount a dummy module (FA-ATNDM) onto an unused slot.

*2: When connecting a cable to the installation base, push the cable connector until it is locked. Failure to do so may cause poor contact.

*3: External connection to 24VDC power supply circuit of Analog Signal Converter must be powered from source compliant with SELV (Safety Extra-Low Voltage) and LIM (Limited energy circuit) according to UL 61010-2-201 or Class2 power supply.

●Block diagram

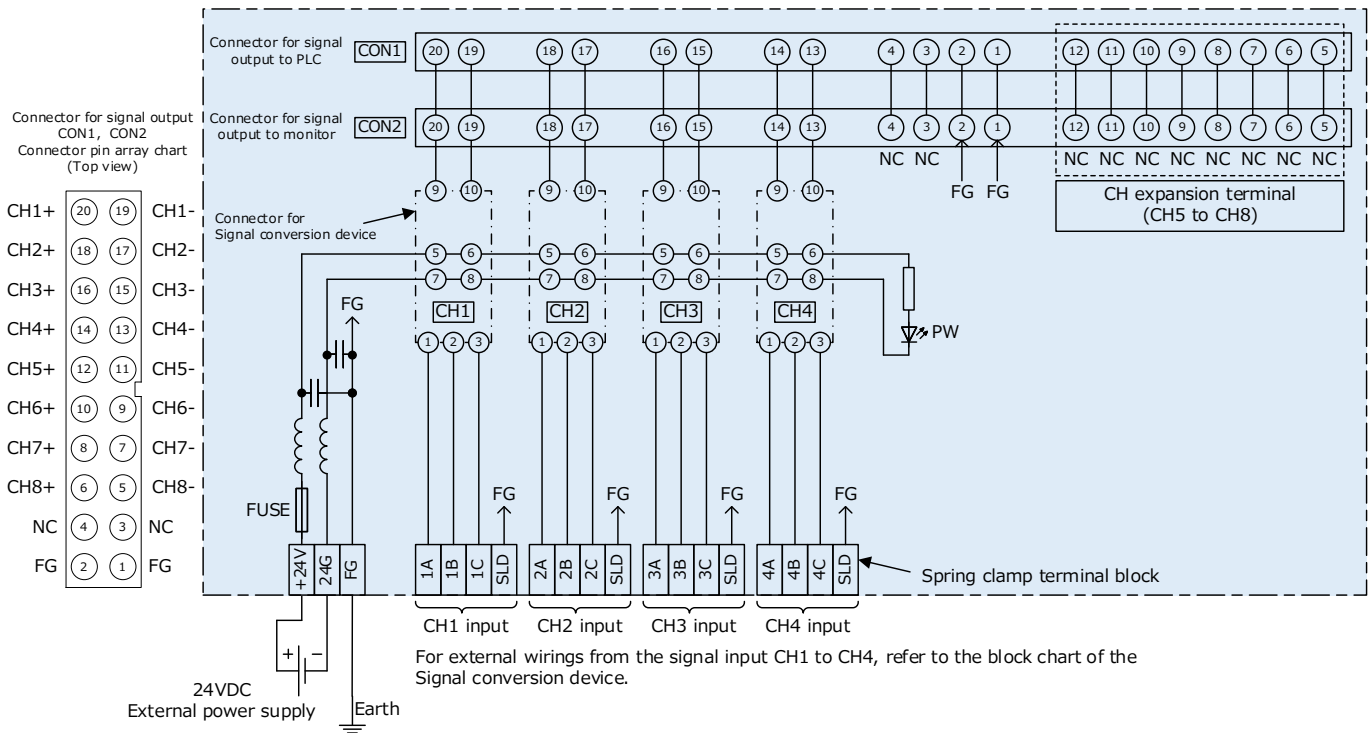

Notes:

- For a device connected to a monitor output, use a device with sufficiently large input resistance. (1MΩ or more is recommended.)
- The monitor output signal voltage differs depending on the output signal of the mounted module.
- Use shielded cables for external wirings.
- Use an input signal conversion device. Using an output signal conversion device incorrectly may damage the product.

3-4. Input type 4-channel installation base, terminal block type (FA1-AT1B4X1TB)

Model name		FA1-AT1B4X1TB ²
Item		
Number of slots ^{*1}		4
Terminal block	Terminal screw	M3 screw, Pitch of 7.62mm, Self tightening screw with finger protector cover
	Applicable wire	0.3 to 2.0mm ² (22 to 14 AWG), Copper wire with a temperature rating of 75°C or more
	Tightening torque	58.8 to 88.2N·m (6 to 9kgf·cm, 5.22 to 7.5lbf·in), UL standard conformity tightening torque : 59N·m , 5.22 lbf·in.)
Module mounting	Mounting screws	M4 × 0.7mm × 22mm or greater Tightening torque range: 78 to 118N·m (8 to 12kgf·cm)
	DIN rail	Applicable DIN rail : TH35-7.5Fe, TH35-7.5Al (compliant with IEC 60715)
External supply power ^{*3}		24VDC±10% (ripple ratio: within 5%, SELV and LIM or CLASS 2)
Current consumption (24VDC)		6mA or less (not including current consumption by the conversion device, the Signal through device, the programmable controller, and the monitor equipment)
Withstand voltage/insulation resistance		Between input/output/power supply: 500VAC for 1 minute, 10MΩ or more
Weight		About 220g

*1: Mount a dummy module (FA-ATNDM) onto an unused slot.

*2: When connecting a cable to the installation base, push the cable connector until it is locked. Failure to do so may cause poor contact.

*3: External connection to 24VDC power supply circuit of Analog Signal Converter must be powered from source compliant with SELV (Safety Extra-Low Voltage) and LIM (Limited energy circuit) according to UL 61010-2-201 or Class2 power supply.

●Block diagram

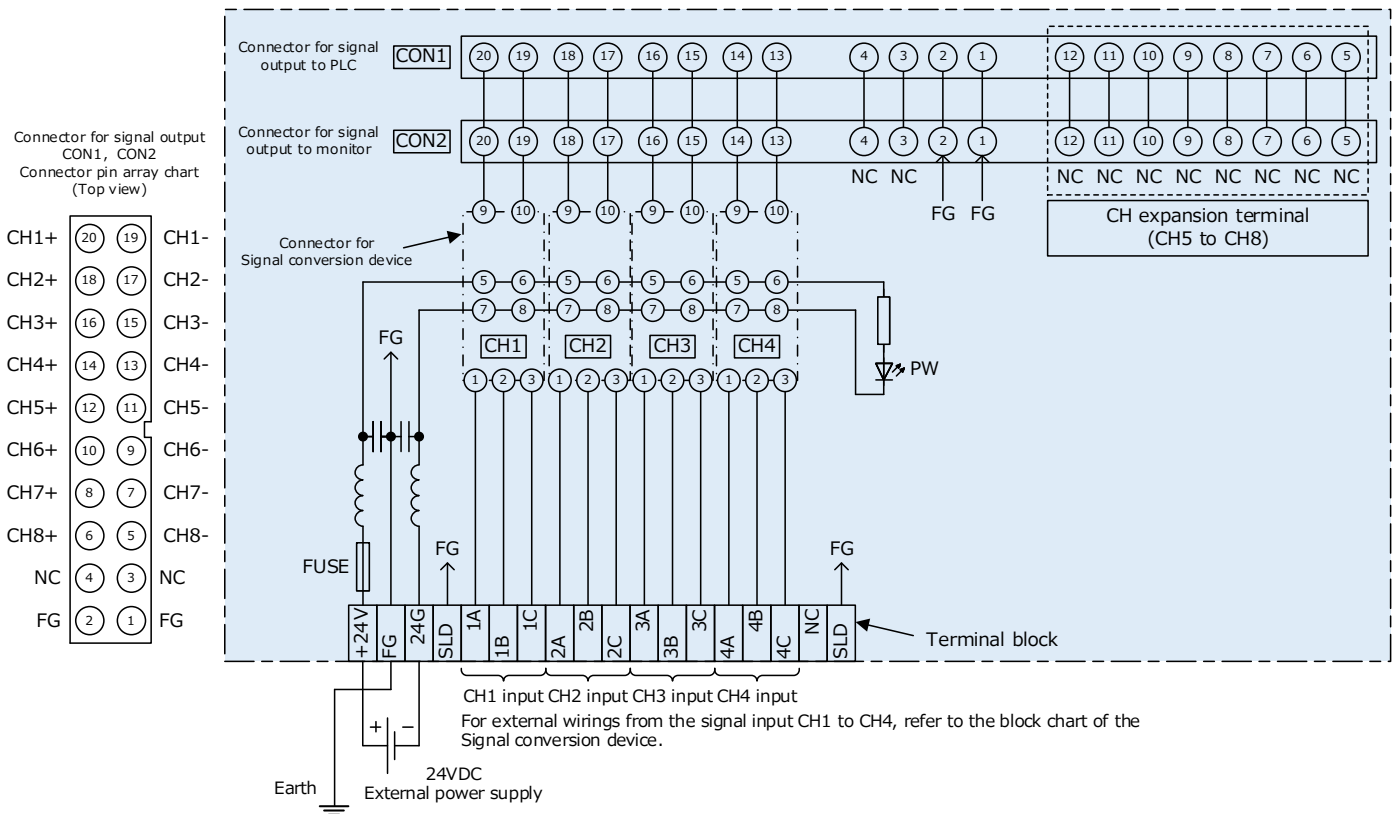

Notes:

- For a device connected to a monitor output, use a device with sufficiently large input resistance. (1MΩ or more is recommended.)
- The monitor output signal voltage differs depending on the output signal of the mounted module.
- Use shielded cables for external wirings.
- Use an input signal conversion device. Using an output signal conversion device incorrectly may damage the product.

3-5. Input type installation base with connector for adapter (FA-ATKB8XTB)

Item	Model	FA-ATKB8XTB
Number of slots*1		8
Terminal block (IN1, OUT2)	Terminal screw	M3 screw, 7.62mm pitch, spring-up screw with finger protector cover Tightening torque range: 58.8 to 88.2N·cm (6 to 9kgf·cm, 5.22 to 7.5lbf·in), UL standard conformity tightening torque: 59N·cm, 5.22lbf·in
	Applicable wire	22 to 14 AWG: 0.3 to 2.0mm ² (when solderless terminals are used)
Installation method	Screw	M4 × 0.7mm × 20mm or more Tightening torque range: 78 to 118N·cm (8 to 12kgf·cm, 7 to 10lbf·in)
	DIN rail	Applicable DIN rail: TH35-7.5Fe, TH35-7.5Al (compliant with IEC 60715)
External power supply		24VDC±10%
Current consumption (24VDC)		6mA or less (not including current consumption of the conversion adapter and signal conversion module)
Withstand voltage, insulation resistance		750VAC for 1 minute, 10MΩ or higher between each input channels/each output channels/power supply
Weight		Approx. 370g

*1: Mount a dummy module (FA-ATNDM) onto an unused slot.

●Block diagram

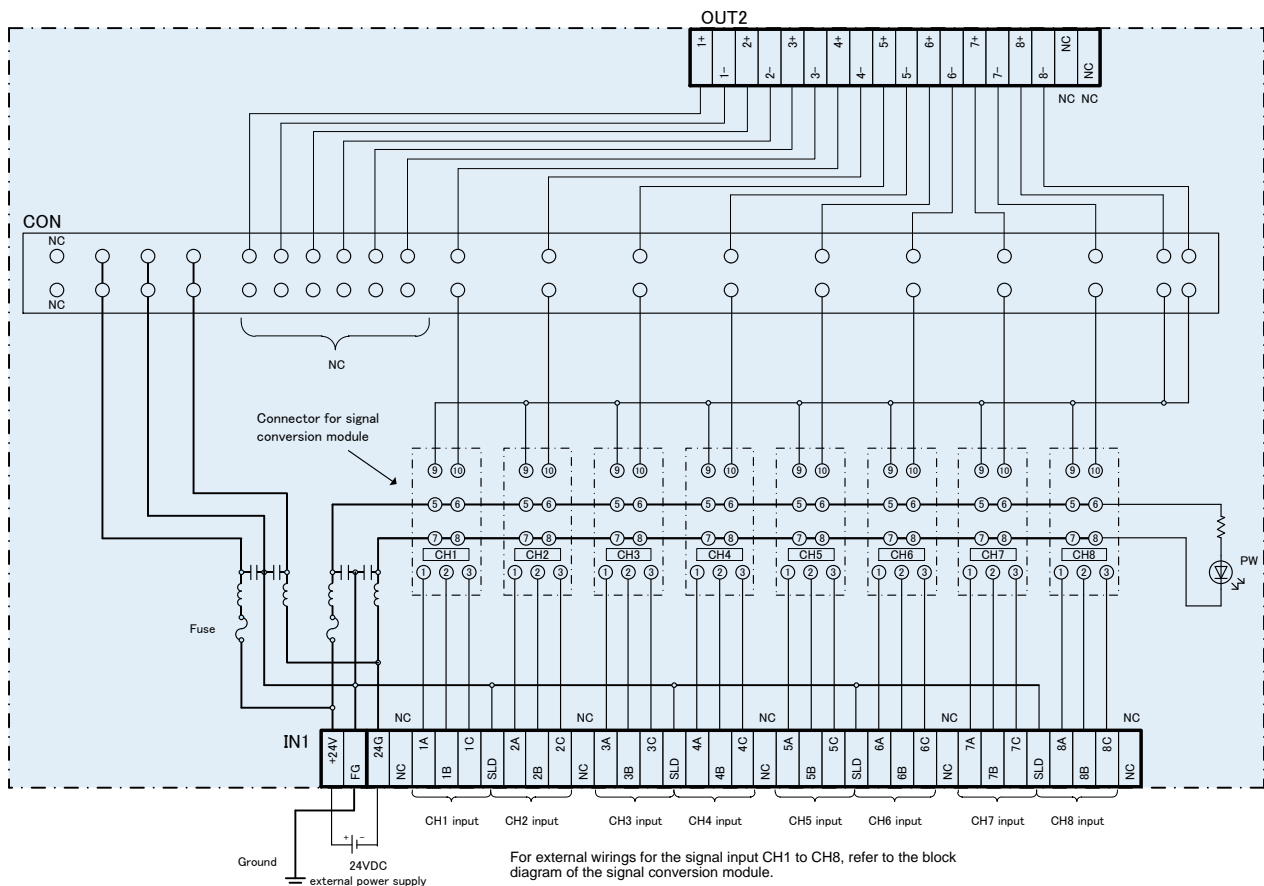

Notes:

- Use shielded cables for external wirings.
- Use an input signal conversion device. Using an output signal conversion device incorrectly may damage the product.

Points:

- SLD terminals of the input terminal block IN1 are internally connected to the FG terminal and can be used as relay terminals to ground the shields of the external cables.

3-6. Conversion adapter current connection (two outputs) (FA-ATKAA8XM)

Item	Model	FA-ATKAA8XM
Number of points		8
Input signal		Depends on the output of the dedicated signal conversion module (1 to 5VDC). ^{*1}
Accuracy ^{*2} (to full-scale)	Reference accuracy	±0.1% or less (ambient temperature 25°C±5°C)
	Temperature characteristics	±0.015%/°C or less
Output 1 (OUT1)	Interface	20-pin MIL connector ^{*3}
	Output signal	4 to 20mA
	Allowable load resistance	250 to 350Ω
Output 2 (OUT2)	Interface	Depends on OUT2 of the installation base with connector for adapter.
	Output signal	4 to 20mA
	Allowable load resistance	600Ω or less
Response speed ^{*4}		10ms or less
External power supply		24VDC (via the installation base with connector for adapter)
Current consumption (24VDC)		310mA or less (via the installation base with connector for adapter)
Insulation method		IN1/OUT1 (lumped)/OUT2 (by channel): Transformer
Withstand voltage, insulation resistance		750VAC for 1 minute, 10MΩ or higher between IN1/OUT1 (lumped)/OUT2 (by channel)/power supply
Weight		Approx. 200g

*1: Current signal input of the pass-through module (FA-ATFTMX) cannot be used.

*2: Accuracy is actually affected by the combination of the signal conversion modules characteristics to be mounted. Calculate the total accuracy as follows:

Example: When the FA-ATSVM1XA420 is used

Reference accuracy: ±0.2% = ±0.1% (Conversion adapter) + ±0.1% (Signal conversion module)

Temperature characteristics: ±0.030%/°C = ±0.015%/°C (Conversion adapter) + ±0.015%/°C (Signal conversion module)

*3: When connecting a cable to the installation base, push the cable connector until it is locked. Failure to do so may cause poor contact.

*4: A time from when a startup pulse is input until the output level reaches 90%

●Block diagram

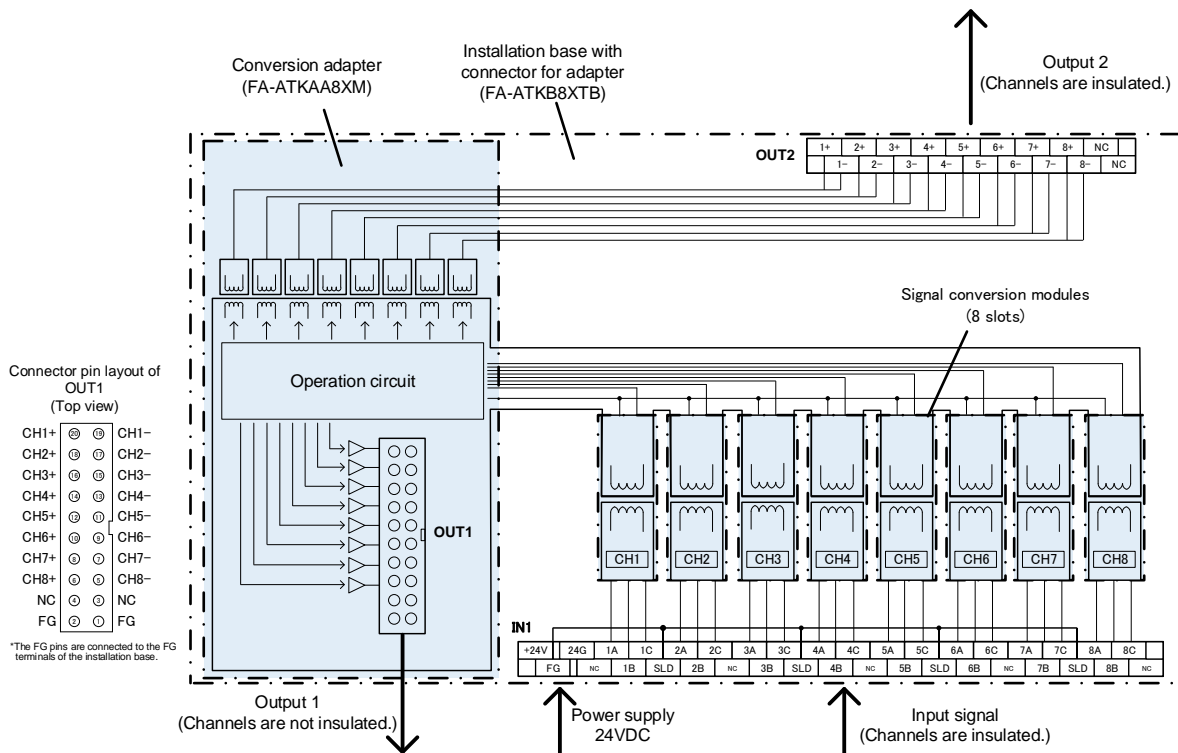

3-7. Voltage input signal conversion module (FA-ATSVM1XV****)

Item		Model	FA-ATSVM1XV05	FA-ATSVM1XV15	FA-ATSVM1XV1010
Number of points			1 point (1 channel)		
Input	Input signal		0 to 5V	1 to 5V	-10 to +10V
	Input resistance		1MΩ or more		
	Disconnection detection function		None		
Accuracy (to full-scale)	Reference accuracy		±0.1% or less (ambient temperature 25°C±5°C)		
	Temperature characteristics		±0.015%/°C or less		
Output (Programmable controller side)	Output signal		1 to 5V		
	Output allowable load resistance		10kΩ or more		
Response speed*1			15ms or less		
Zero/span adjustment			Zero adjustment range: -2 to 2%, span adjustment range: 98 to 102%		
Power supply			24VDC±10% (supplied from the installation base)		
Current consumption (24VDC)			20mA or less		
Insulation method			Transformer		
Withstand voltage, insulation resistance			750VAC for 1 minute, 10MΩ or higher between input/output/power supply		
Weight			Approx. 30g		

*1: A time from when a startup pulse is input until the output level reaches 90%.

•Block diagram

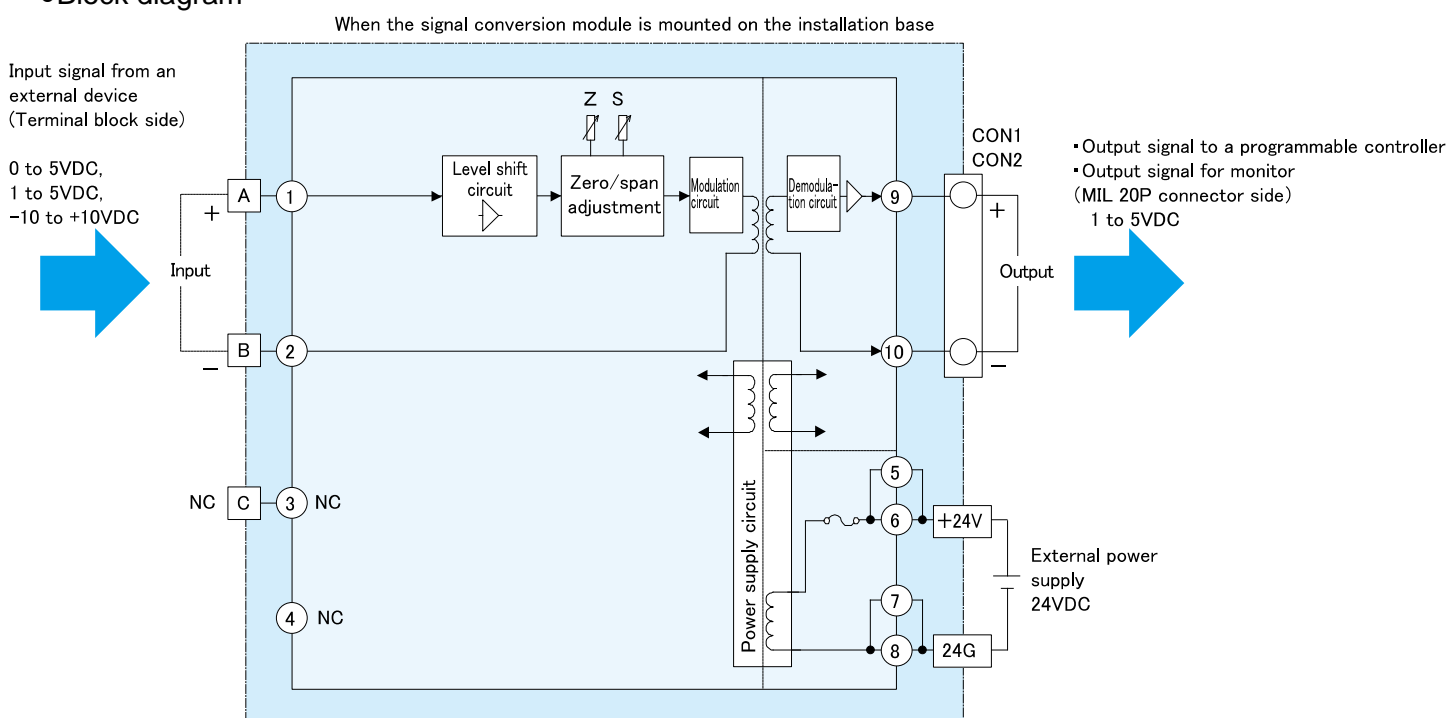

3-8. Current input signal conversion module (FA-ATSVM1XA420)

Item	Model	FA-ATSVM1XA420
Number of points		1 point (1 channel)
Input	Input signal	4 to 20mA
	Input resistance	250Ω
	Disconnection detection function	None
Accuracy (to full-scale)	Reference accuracy	±0.1% or less (ambient temperature 25°C±5°C)
	Temperature characteristics	±0.015%/°C or less
Output (Programmable controller side)	Output signal	1 to 5V
	Output allowable load resistance	10kΩ or more
Response speed*1		15ms or less
Zero/span adjustment		Zero adjustment range: -2 to 2%, span adjustment range: 98 to 102%
Power supply		24VDC±10% (supplied from the installation base)
Current consumption (24VDC)		20mA or less
Insulation method		Transformer
Withstand voltage, insulation resistance		750VAC for 1 minute, 10MΩ or higher between input/output/power supply
Weight		Approx. 30g

*1: A time from when a startup pulse is input until the output level reaches 90%.

●Block diagram

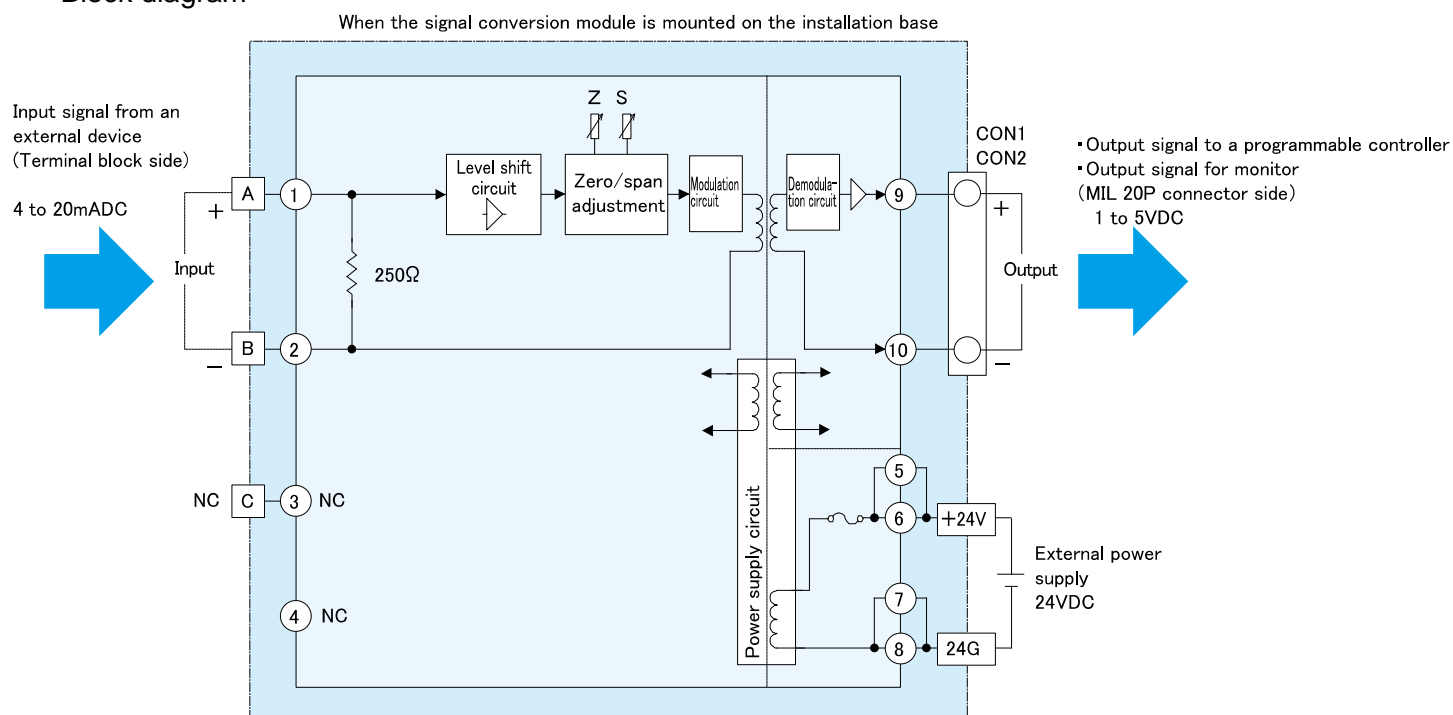

3-9. Distributor signal conversion module (2-wire transmitter) (FA-ATSVM1XD)

Item	Model	FA-ATSVM1XD ²
Number of points		1 point (1 channel)
Input	Input signal	2-wire transmitter
	Input resistance	250Ω
	Disconnection detection function	None
Power supply for transmitter	Supply voltage	26VDC±2V
	Maximum supply current	24mA
	Short-circuit protection	Supported (Current limitation: 25 to 35mA)
Accuracy (to full-scale)	Reference accuracy	±0.1% or less (ambient temperature 25°C±5°C)
	Temperature characteristics	±0.015%/°C or less
Output (Programmable controller side)	Output signal	1 to 5V
	Output allowable load resistance	10kΩ or more
Response speed ¹		15ms or less
Zero/span adjustment		Zero adjustment range: -2 to 2%, span adjustment range: 98 to 102%
Power supply		24VDC±10% (supplied from the installation base)
Current consumption (24VDC)		68mA or less
Insulation method		Transformer
Withstand voltage, insulation resistance		750VAC for 1 minute, 10MΩ or higher between input/output/power supply
Weight		Approx. 30g

*1: A time from when a startup pulse is input until the output level reaches 90%.

*2: Note that the installation orientation is restricted when three or more modules are mounted on the installation base.

●Block diagram

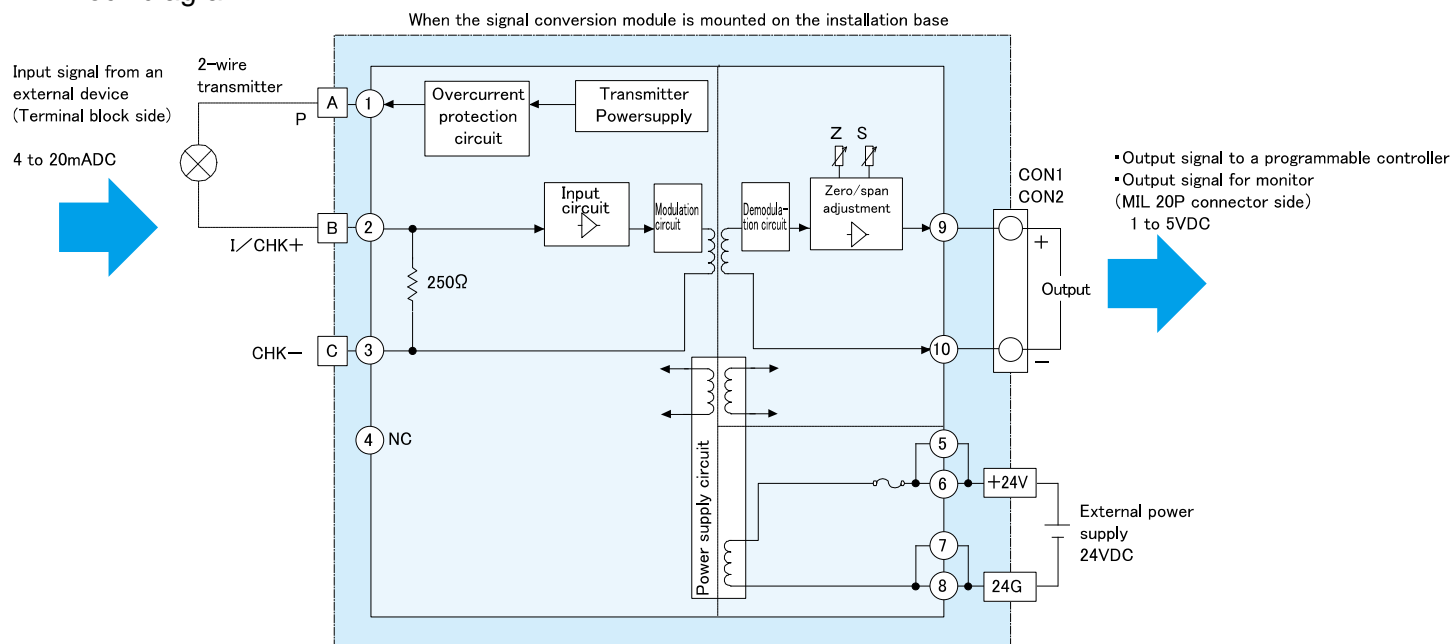

3-10. Thermocouple temperature input signal conversion module (FA-ATSVM1XT*)

[Type K thermocouple]

Model		FA-ATSVM1XTK	FA-ATSVM1XTK0040	FA-ATSVM1XTK0060	FA-ATSVM1XTK0080
Number of points		1 point (1 channel)			
Input	Input signal	Thermocouple	Type K		
		Temperature range ^{*2}	-200 to 1200°C	0 to +400°C	0 to +600°C
	Input resistance	1MΩ or more			
Disconnection detection function		Supported (upscale burnout)			
Accuracy (to full-scale)	Reference accuracy		±0.1% or less (ambient temperature 25°C±5°C)		
	Linearization error		±0.1% or less		
	Temperature characteristics		±0.015%/°C or less		
	Cold junction compensation accuracy		±0.5°C or less (25°C±5°C), ±1°C or less (0 to 55°C)		
Output (Programmable controller side)	Output signal		1 to 5V		
	Output allowable load resistance		10kΩ or more		
Response speed ^{*1}		100ms or less			
Zero/span adjustment		Zero adjustment range: -2 to 2%, span adjustment range: 98 to 102%			
Power supply		24VDC±10% (supplied from the installation base)			
Current consumption (24VDC)		24mA or less			
Insulation method		Transformer			
Withstand voltage, insulation resistance		750VAC for 1 minute, 10MΩ or higher between input/output/power supply			
Weight		Approx. 40g			

*1: A time from when a startup pulse is input until the output level reaches 90%.

*2: The input range (temperature range) is fixed.

[Type B, S, E, T, R, J, N thermocouple]

Model		FA-ATSVM1XTB	FA-ATSVM1XTS	FA-ATSVM1XTE	FA-ATSVM1XTT	FA-ATSVM1XTR	FA-ATSVM1XTJ	FA-ATSVM1XTN	
Number of points		1 point (1 channel)							
Input	Input signal	Thermocouple	Type B	Type S	Type E	Type T	Type R	Type J	Type N
		Temperature range ^{*2}	+600 to +1700°C	0 to +1600°C	-200 to +900°C	-200 to +350°C	0 to +1600°C	-40 to +750°C	-200 to +1250°C
	Input resistance	1MΩ or more							
Disconnection detection function		Supported (upscale burnout)							
Accuracy (to full-scale)	Reference accuracy		±0.1% or less (ambient temperature 25°C±5°C)						
	Linearization error		±0.1% or less						
	Temperature characteristics		±0.015%/°C or less						
	Cold junction compensation accuracy		±0.5°C or less (25°C±5°C), ±1°C or less (0 to 55°C)						
Output (Programmable controller side)	Output signal		1 to 5V						
	Output allowable load resistance		10kΩ or more						
Response speed ^{*1}		100ms or less							
Zero/span adjustment		Zero adjustment range: -2 to 2%, span adjustment range: 98 to 102%							
Power supply		24VDC±10% (supplied from the installation base)							
Current consumption (24VDC)		24mA or less							
Insulation method		Transformer							
Withstand voltage, insulation resistance		750VAC for 1 minute, 10MΩ or higher between input/output/power supply							
Weight		Approx. 40g							

*1: A time from when a startup pulse is input until the output level reaches 90%.

*2: The input range (temperature range) is fixed.

●Block diagram^{*3}

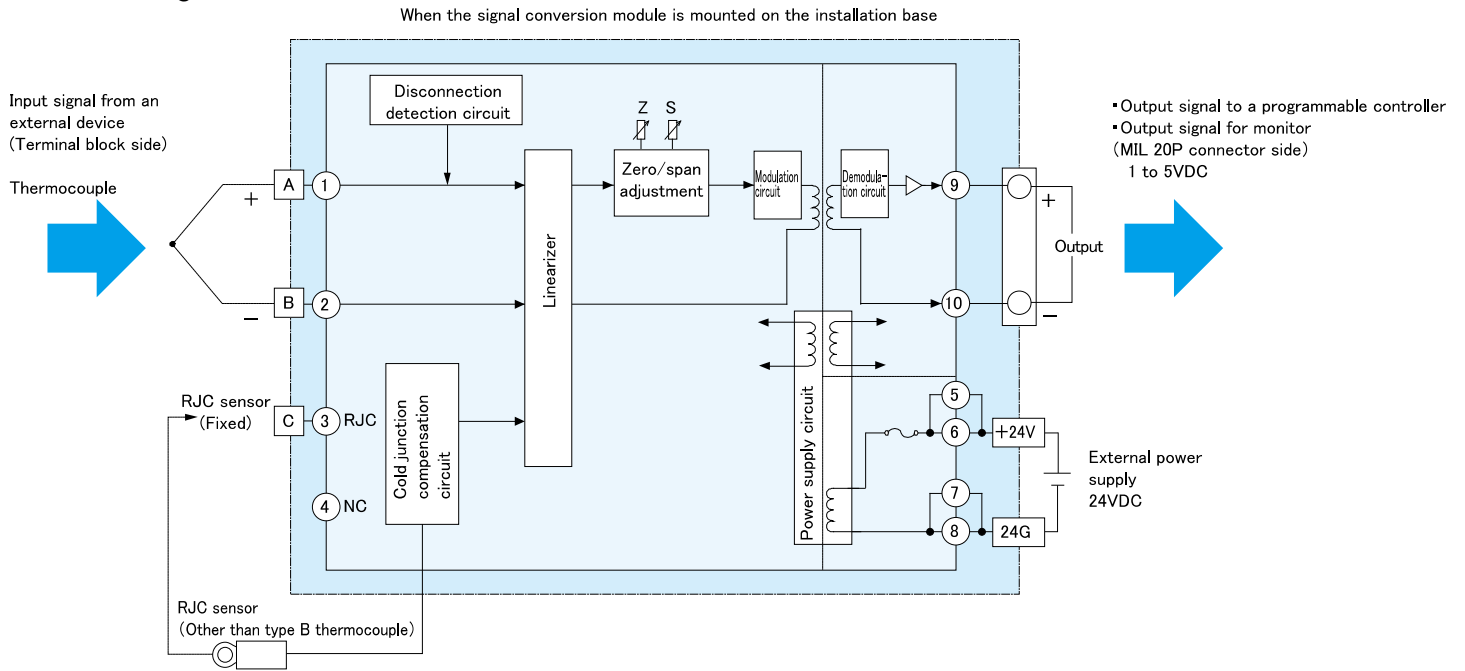

*3: Applied to products which have "K" or later at the alphabet part in the SERIAL field.

3-11. RTD input signal conversion module (FA-ATSVM1XR^{***})

Item		Model	FA-ATSVM1XRPT	FA-ATSVM1XRPT0010	FA-ATSVM1XRPT0020	FA-ATSVM1XRJPT
Number of points			1 point (1 channel)			
Input	Input signal	RTD	Type Pt100			Type JPt100
		Temperature range ^{*2}	-200 to +650°C	0 to +100°C	0 to +200°C	-200 to +600°C
		Disconnection detection function	Supported (upscale burnout)			
Accuracy (to full-scale)	Reference accuracy		±0.1% or less (ambient temperature 25°C±5°C)			
	Linearization error		±0.1% or less			
	Temperature characteristics		±0.010%/°C or less			
Output (Programmable controller side)	Output signal		1 to 5V			
	Output allowable load resistance		10kΩ or more			
Response speed ^{*1}		100ms or less				
Zero/span adjustment		Zero adjustment range: -2 to 2%, span adjustment range: 98 to 102%				
Power supply		24VDC±10% (supplied from the installation base)				
Current consumption (24VDC)		25mA or less				
Insulation method		Transformer				
Withstand voltage, insulation resistance		750VAC for 1 minute, 10MΩ or higher between input/output/power supply				
Weight		Approx. 40g				

*1: A time from when a startup pulse is input until the output level reaches 90%.

*2: The input range (temperature range) is fixed.

●Block diagram^{*3}

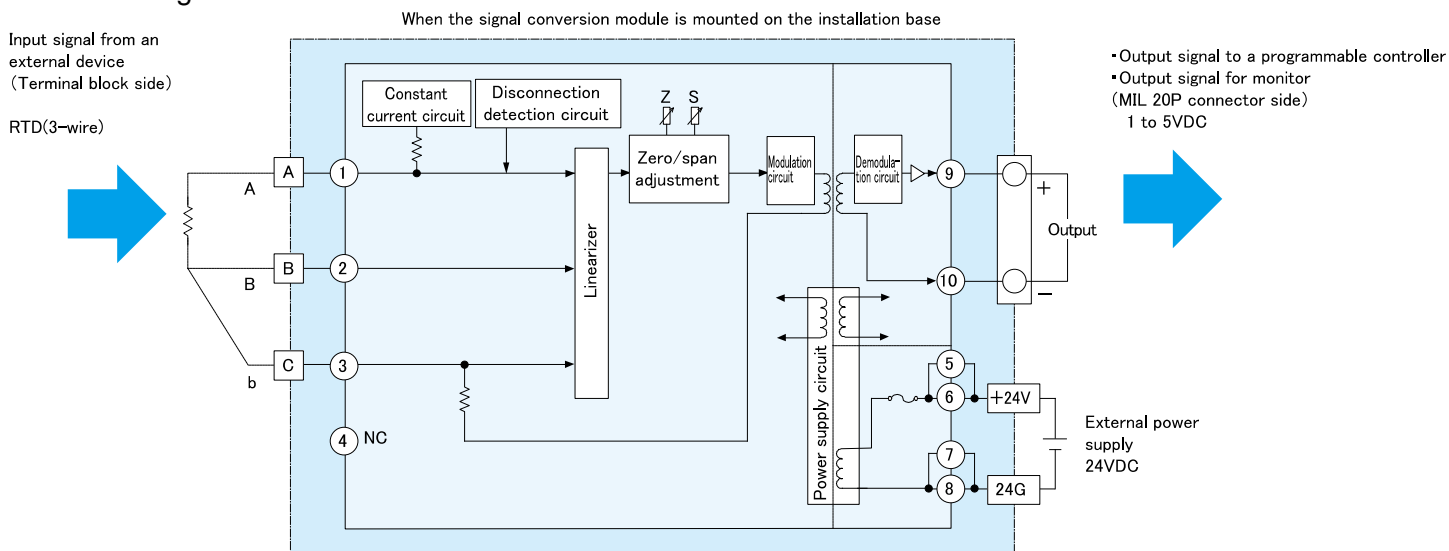

*3: Applied to products which have "K" or later at the alphabet part in the SERIAL field.

3-12. CT input signal conversion module (FA1-AT1CT-1-6)

Item		Model	FA1-AT1CT-1-6
Number of points			1 point (1 channel)
Operation method			Effective value operation
Input	Input signal		Alternating current from the CT (Current Transformer)
	Input range	Primary current (Input to the CT)	0 to 5AAC / 0 to 50AAC / 0 to 100AAC / 0 to 600AAC
		Secondary current (Input to the installation base)	0 to 1.67mAAC / 0 to 16.67mAAC / 0 to 33.33mAAC / 0 to 66.7mAAC
	Input frequency		50/60Hz
	Disconnection detection function		None
Accuracy ^{*1,2} (to full-scale)	Ambient temperature (25 ± 5°C)		Within ± 0.5%
	Ambient temperature (0 to 55°C)		Within ± 1.0%
Output (Programmable controller side)	Output signal		1 to 5V
	Output allowable load resistance		10kΩ or more
Response speed ^{*3}			400ms or less
Zero/span adjustment			Zero adjustment range: -2 to 2%, span adjustment range: 98 to 102%
Power supply			24VDC±10% (supplied from the installation base, SELV and LIM)
Current consumption (24VDC)			20mA or less
Insulation method			Transformer
Withstand voltage, insulation resistance			750VAC for 1 minute, 10MΩ or higher between input/output/power supply
Weight			Approx. 30g

*1: Except in case when the CT input signal conversion module is influenced by noise.

*2: The accuracy when a CT is connected is a sum of the CT input signal conversion module's accuracy and the CT's accuracy.

The following is the formula to calculate accuracy.

$$(\text{Accuracy}) = (\text{Accuracy of the CT input signal conversion module}) + (\text{Accuracy of the CT to be used})$$

For the accuracy of the CT to be used, contact its manufacturer.

*3: A time from when a startup pulse is input until the output level reaches 90%.

●Block diagram

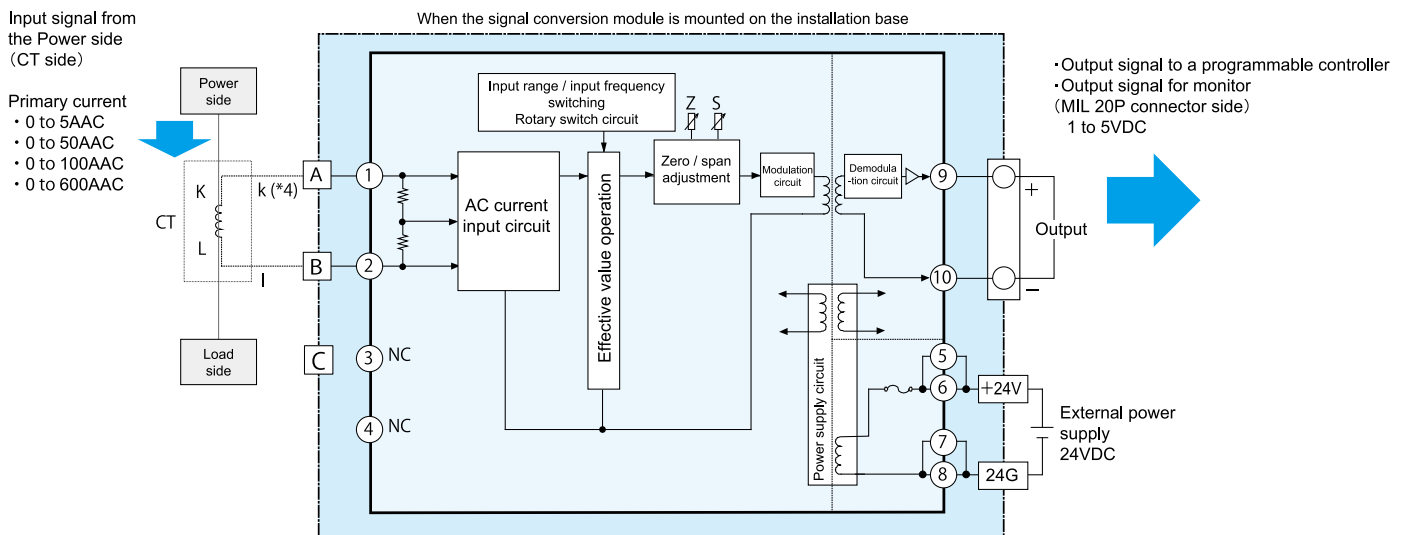

*4: The secondary current (equivalent to 0 to 66.7mAAC) output from the CT is input to the base unit (terminal block side).

Avoid inputting the value that is 70mAAC or more to the installation base.

●Input range / input frequency switching

By setting the rotary switch to each number, the input range and input frequency can be switched.
 The rotary switch setting is activated by turning on the power supply.
 Set the rotary switch before attaching it to the base unit.

External view of CT input signal conversion module (FA1-AT1CT-1-6)

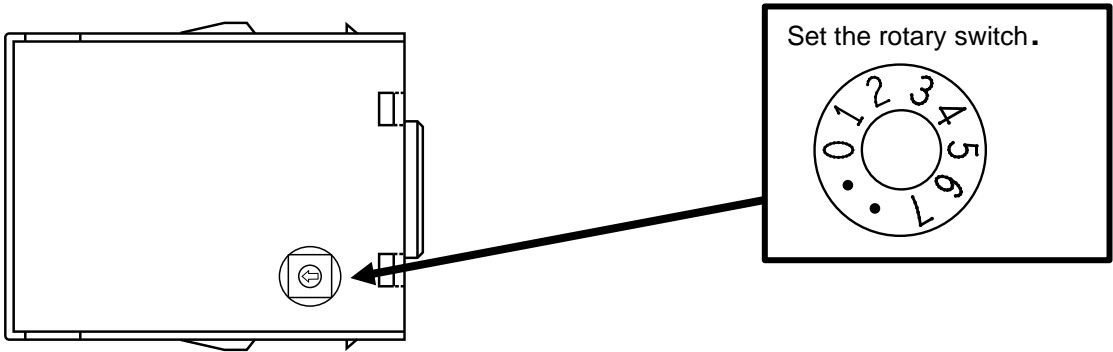

The following table lists the rotary switch number and input range/frequency combinations.

Rotary switch number	Input range		Input frequency
	Primary current (Input to the CT)	Secondary current (Input to the installation base)	
0	0 to 5AAC	0 to 1.67mAAC	50Hz
1	0 to 50AAC	0 to 16.67mAAC	
2	0 to 100AAC	0 to 33.33mAAC	
3	0 to 600AAC	0 to 66.7mAAC	
4	0 to 5AAC	0 to 1.67mAAC	60Hz
5	0 to 50AAC	0 to 16.67mAAC	
6	0 to 100AAC	0 to 33.33mAAC	
7	0 to 600AAC	0 to 66.7mAAC	

●Products prepared by user

(a) CT

The following table lists the CT that is available for a connection with the installation base.

Manufacturer	Model name	Input range	Secondary winding
Mitsubishi Electric Corporation	EMU-CT5-A	0 to 5AAC	3000 turns
	EMU-CT50-A	0 to 50AAC	3000 turns
	EMU-CT100-A	0 to 100AAC	3000 turns
	EMU-CT400-A*1	0 to 400AAC	6000 turns
	EMU-CT600-A	0 to 600AAC	9000 turns

*1 When using the EMU-CT400-A, set the rotary switch to "3" when the input frequency is 50Hz, and set the rotary switch to "7" when the input frequency is 60Hz.

(b) Connection cable

Use a shielded twisted pair cable for a connection between the installation base and CT.

3-13. Pass-through module (FA-ATFTMX)

Item		Model	FA-ATFTMX	
Number of points			1 point (1 channel)	
Input signal			Voltage input	Current input ^{*1,2}
Conversion type			When signals are passed through	When current is converted to voltage
Input	Resistance		—	250Ω
	Resistor accuracy		—	±0.1% or less
	Temperature characteristics of resistor		—	±0.0025%/°C or less
Allowable I/O signal			Voltage: 10V or less, Current: 20mA or less	
Weight			Approx. 30g	

*1: When current is converted to voltage, short across terminals A and C of the installation base terminal block.

*2: When the conversion adapter (FA-ATKAA8XM) is used, current cannot be input to the pass-through module.

●Block diagram

Voltage input: when signals are passed through

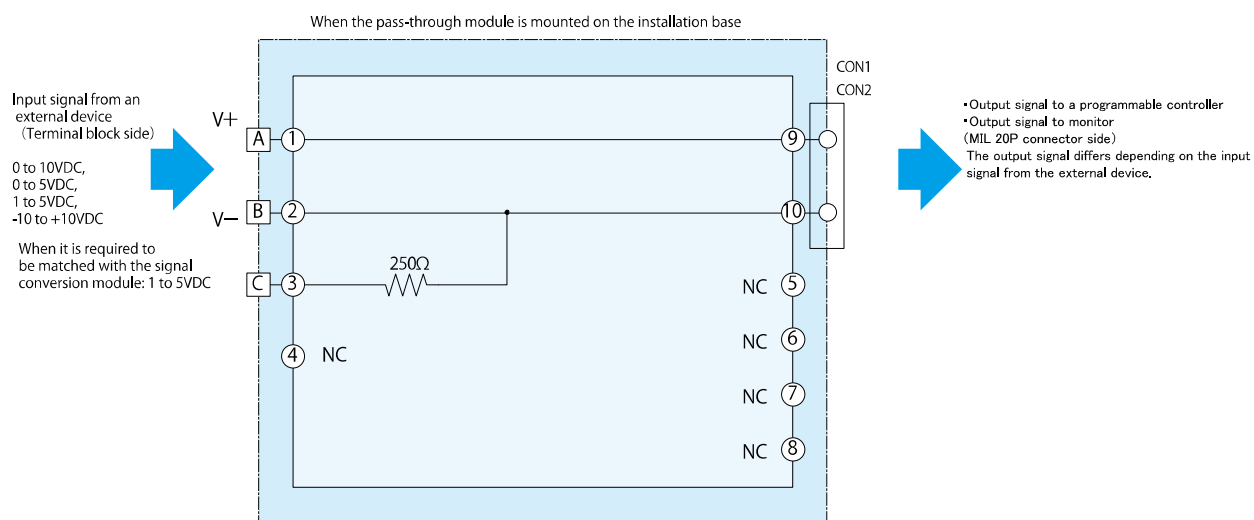

Current input: when current is converted to voltage

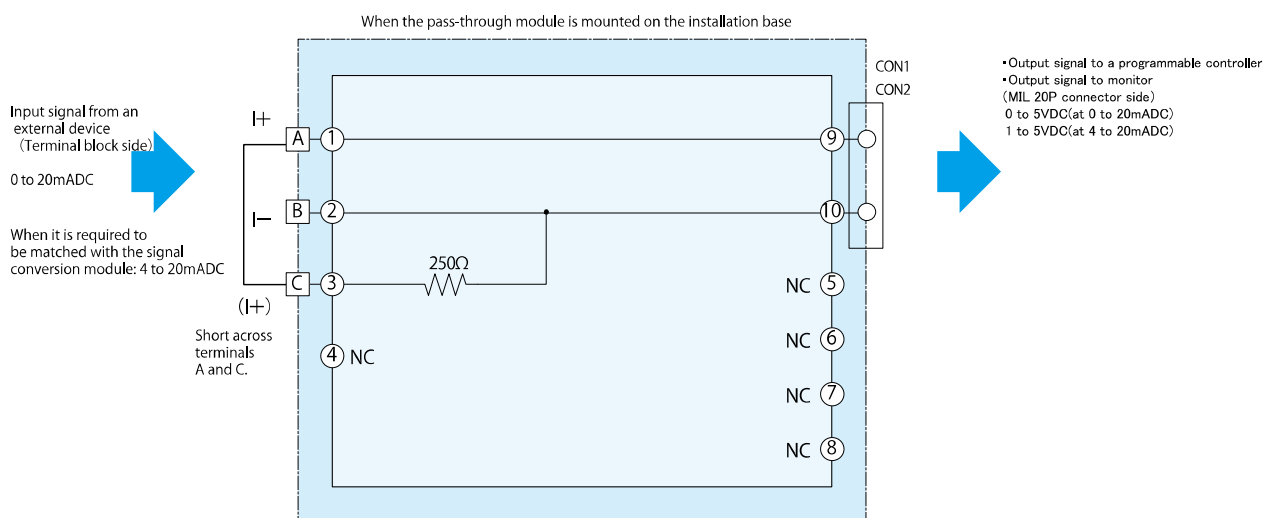

3-14. Terminal block ↔ connector conversion adapter (FA-Q6TCA)

Item		Model	FA-Q6TCA
Rated voltage, rated current			Voltage: 121VDC / 264VAC, Current: 2A (Terminal No.1 to 16) / 8A (Terminal No.17, 18)
Tightening torque			66 to 89N·cm (7 to 9kgf·cm, 6.08 to 7.81lbf·in)
Weight			Approx. 80g

4. CONNECTABLE MODULES AND CABLES

Module model for a programmable controller		Input range	Installation base	Signal conversion module	Cable model
MELSEC iQ-R series	R60ADI8	4 to 20mA	FA-ATKB8XTB + FA-ATKAA8XM	Voltage input FA-ATSVM1XV05 FA-ATSVM1XV15 FA-ATSVM1XV1010 Current input FA-ATSVM1XA420 distributor FA-ATSVM1XD Thermocouple temperature input FA-ATSVM1XTB FA-ATSVM1XTR FA-ATSVM1XTS FA-ATSVM1XTK FA-ATSVM1XTK0040 FA-ATSVM1XTK0060 FA-ATSVM1XTK0080 FA-ATSVM1XTE FA-ATSVM1XTJ FA-ATSVM1XTT FA-ATSVM1XTN RTD input FA-ATSVM1XRPT FA-ATSVM1XRPT0010 FA-ATSVM1XRPT0020 FA-ATSVM1XRJPT CT input FA1-AT1CT-1-6 When signals are passed through FA-ATFTMY	FA-CBL**ATQ8XVT
MELSEC-Q series	Q68ADI	4 to 20mA			FA-CBL**ATQ8XVA *1
	Q64AD-GH				FA-CBL**ATQ8XVT
MELSEC-L series	L60ADIL8	4 to 20mA			FA-CBL**ATQ8XVA *1
MELSEC iQ-F series	FX5-8AD	4 to 20mA			FA-CBL**ATF
MELSEC-F series	FX3U-4AD	4 to 20mA			FA2-CB2L**AT8XV1E
	FX3U-4AD-ADP				
	FX3UC-4AD				
	FX2N-8AD				
CC-Link IE TSN	NZ2GN2B-60AD4	4 to 20mA			FA-CBL**ATF
CC-Link IE Field	NZ2GFCE-60ADI8	4 to 20mA			
	NZ2GF2BN-60AD4				
CC-Link	AJ65SBT-64AD	4 to 20mA			
	AJ65SBT2B-64AD				
Programmable controllers from various manufacturers	General-purpose analog input module	4 to 20mA			
Computers from various manufacturers		4 to 20mA			
MELSEC iQ-R series	R60ADV8	1 to 5V	FA1-AT1B8X1TE FA-ATB8XTB	FA-CBL**ATQ8XVT	
MELSEC-Q series	Q68ADV	1 to 5V		FA-CBL**ATQ8XVA *1	
	Q64AD-GH			FA-CBL**ATQ8XVT	
MELSEC-L series	L60ADVL8	1 to 5V		FA-CBL**ATQ8XVA *1	
MELSEC iQ-F series	FX5-8AD	1 to 5V		FA-CBL**ATF	
MELSEC-F series	FX3U-4AD	1 to 5V		FA2-CB2L**AT8XV1E	
	FX3U-4AD-ADP				
	FX3UC-4AD				
	FX2N-8AD				
CC-Link IE TSN	NZ2GN2B-60AD4	1 to 5V		Use the cable that comes with the product.	
	FA3-AT1T8X-01C				
	FA3-AT1T8X				
CC-Link IE Field	NZ2GFCE-60ADV8	1 to 5V		FA3-CB2L**MM1H20	
	NZ2GF2BN-60AD4				
CC-Link	AJ65SBT-64AD	1 to 5V		FA-CBL**ATF	
	AJ65SBT2B-64AD				
	FA3-AT1C8X-01C				
	FA3-AT1C8X				
Programmable controllers from various manufacturers	General-purpose analog input module	1 to 5V	Use the cable that comes with the product.		
Computers from various manufacturers		1 to 5V	FA3-CB2L**MM1H20		
			FA-CBL**ATF		

*1: When the FA-Q6TCA is used on the MELSEC iQ-R series / MELSEC-Q series programmable controller side.

Module model for a programmable controller		Number of channels	Input range	Cable for dispersed installation	Installation base	Signal conversion module	Connection cable
MELSEC iQ-R series	R60ADV8	8	1 to 5V	—	FA1-AT1B4X1TE, FA1-AT1B4X1TB	Voltage input FA-ATSVM1XV05 FA-ATSVM1XV15 FA-ATSVM1XV1010 Current input FA-ATSVM1XA420 distributor FA-ATSVM1XD Thermocouple temperature input FA-ATSVM1XTB FA-ATSVM1XTR FA-ATSVM1XTS FA-ATSVM1XTK FA-ATSVM1XTK0040 FA-ATSVM1XTK0060 FA-ATSVM1XTK0080 FA-ATSVM1XTE FA-ATSVM1XTJ FA-ATSVM1XTT FA-ATSVM1XTN RTD input FA-ATSVM1XRPT FA-ATSVM1XRPT0010 FA-ATSVM1XRPT0020 FA-ATSVM1XRJPT CT input FA1-AT1CT-1-6 When signals are passed through FA-ATFTMX	FA-CBL**ATQ8XVT
	R60ADH4	4					FA-CBL**ATQ8XVA *1
	R60AD4						FA1-CB2L**AT4XV1T
MELSEC-Q series	Q68ADV	8	1 to 5V				FA-CBL**ATQ8XVT
	Q64ADH	4					FA-CBL**ATQ8XVA *1
	Q64AD						FA1-CB2L**AT4XV1T
	Q64AD-GH						FA-CBL**ATF
MELSEC-L series	L60ADVL8	8	1 to 5V				FA2-CB2L**AT4XV1E
MELSEC iQ-F series	FX5-4AD	4	1 to 5V				FA-CBL**ATF
MELSEC-F series	FX2N-8AD	8	1 to 5V				
	FX3U-4AD	4					
	FX3U-4AD-ADP						
	FX3UC-4AD						
CC-Link IE TSN	FA3-AT1T8X-01C	8	1 to 5V				Use the cable that comes with the product.
	FA3-AT1T8X						FA3-CB2L**MM1H20
	NZ2GN2S-60AD4	4		FA3-CB2**AT4XV1E			
	NZ2GN2B-60AD4						
CC-Link IE Field	NZ2GFCE-60ADV8	8	1 to 5V	FA-CBL**ATF			
	NZ2GF2BN-60AD4	4					
CC-Link	FA3-AT1C8X-01C	8	1 to 5V	Use the cable that comes with the product.			
	FA3-AT1C8X			FA3-CB2L**MM1H20			
	AJ65SBT-64AD	4		FA-CBL**ATF			
	AJ65SBT2B-64AD						
Programmable controllers from various manufacturers	General-purpose analog input module	Differs depending on the module.	1 to 5V				
Computers from various manufacturers		Differs depending on the module.	1 to 5V				
MELSEC iQ-R series	R60ADV8	8	1 to 5V	FA1-CB2L**AT4EX	FA1-AT1B4X1TE × 2, FA1-AT1B4X1TB × 2	FA-CBL**ATQ8XVT	
		8	1 to 5V			FA-CBL**ATQ8XVA *1	
MELSEC-Q series	Q68ADV	8	1 to 5V			FA-CBL**ATQ8XVT	
		8	1 to 5V			FA-CBL**ATQ8XVA *1	
MELSEC-L series	L60ADVL8	8	1 to 5V			FA-CBL**ATQ8XVT	
MELSEC iQ-F series	FX5-8AD	8	1 to 5V			FA2-CB2L**AT8XV1E	
MELSEC-F series	FX2N-8AD	8	1 to 5V			FA-CBL**ATQ8XVT	
CC-Link IE TSN	FA3-AT1T8X-01C	8	1 to 5V			Use the cable that comes with the product.	
	FA3-AT1T8X					FA3-CB2L**MM1H20	
CC-Link IE Field	NZ2GFCE-60ADV8	8	1 to 5V			FA-CBL**ATF	
CC-Link	FA3-AT1C8X-01C	8	1 to 5V			Use the cable that comes with the product.	
	FA3-AT1C8X					FA3-CB2L**MM1H20	
Programmable controllers from various manufacturers	General-purpose analog input module	Differs depending on the module.	1 to 5V			FA-CBL**ATF	
Computers from various manufacturers		Differs depending on the module.	1 to 5V				

*1: When the FA-Q6TCA is used on the MELSEC iQ-R series / MELSEC-Q series programmable controller side.

5. EXTERNAL DIMENSIONS

5-1. Input type 8-channel installation base, spring clamp terminal block type (FA1-AT1B8X1TE)

[Unit : mm]

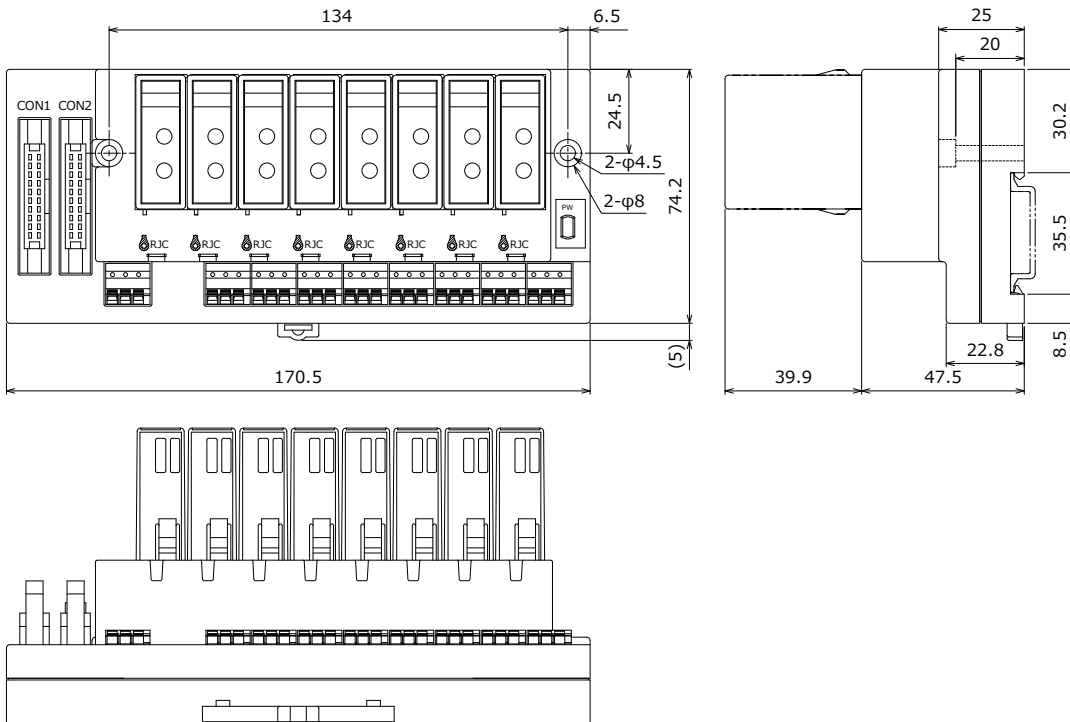

5-2. Input type 8-channel installation base, screw terminal block type (FA-ATB8XTB)

[Unit : mm]

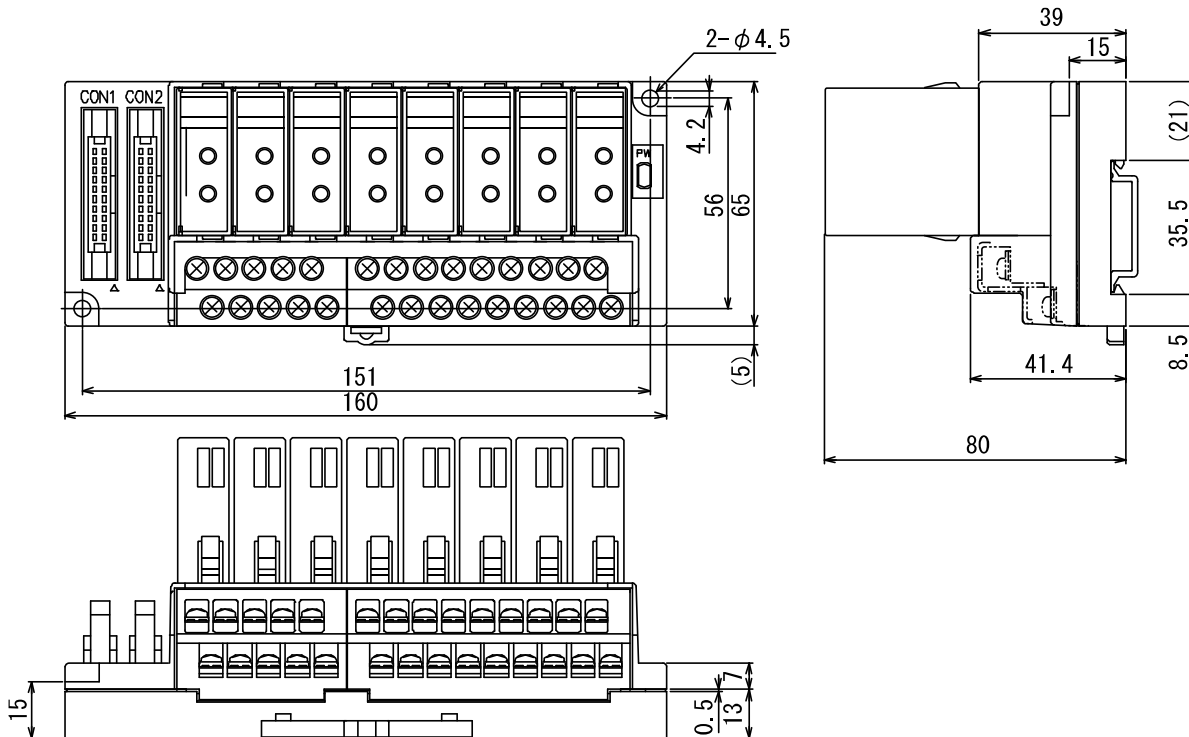

5-3. Input type 4-channel installation base, spring clamp terminal block type (FA1-AT1B4X1TE)

[Unit : mm]

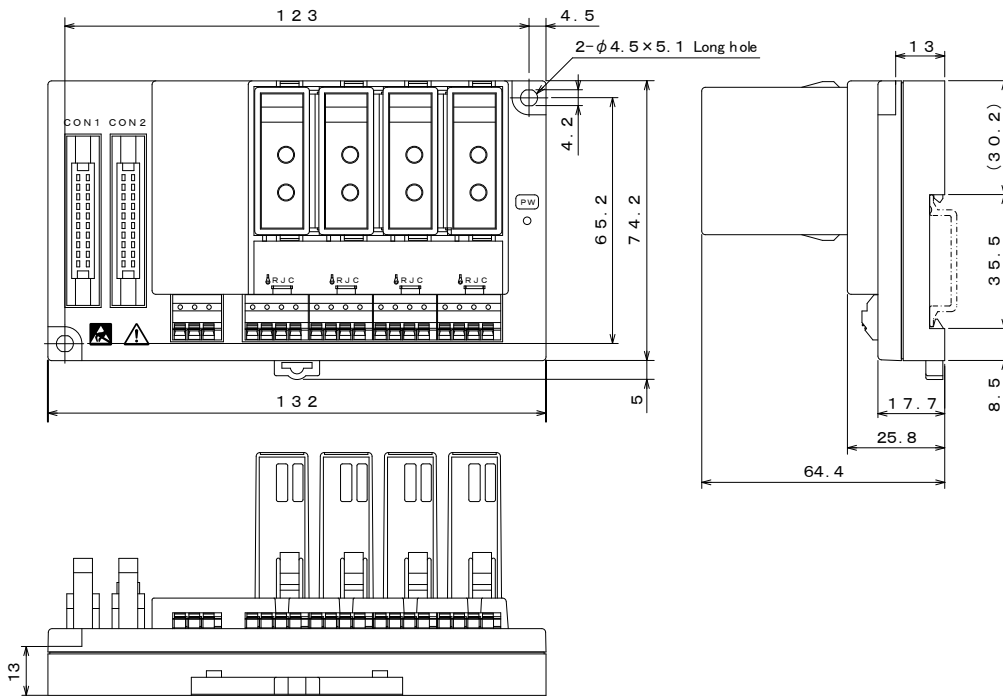

5-4. Input type 4-channel installation base, terminal block type (FA1-AT1B4X1TB)

[Unit : mm]

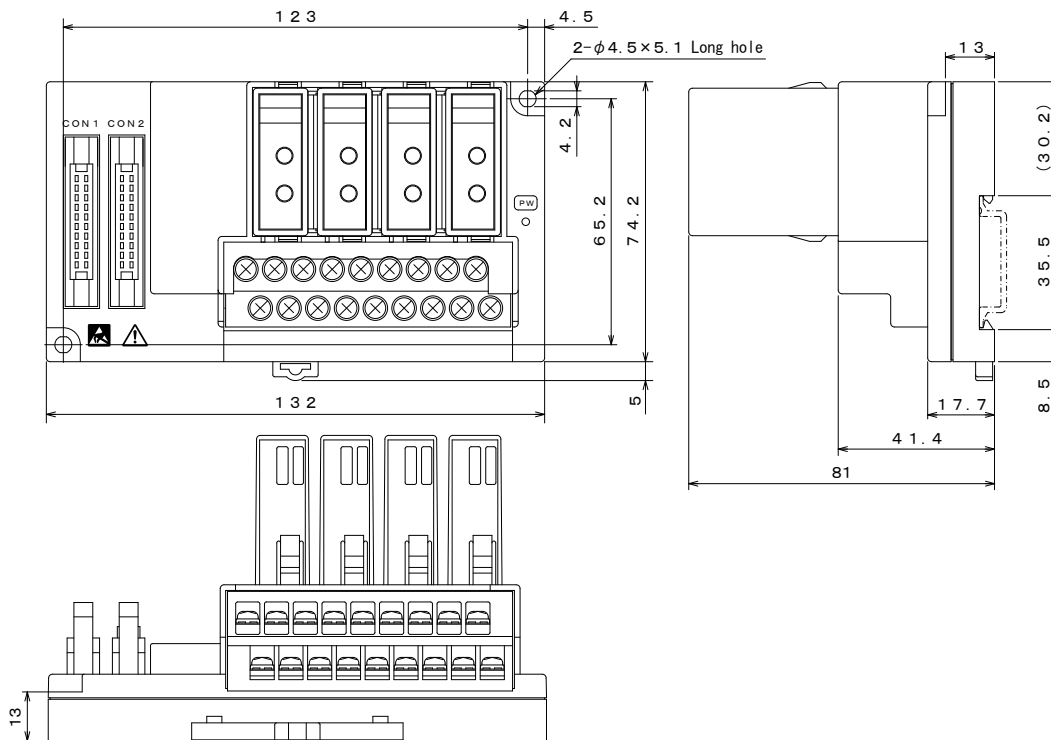

5-5. Input type installation base with connector for adapter (FA-ATKB8XTB)

When the conversion adapter, the signal conversion modules and/or the pass-through modules are mounted on the installation base.

[Unit : mm]

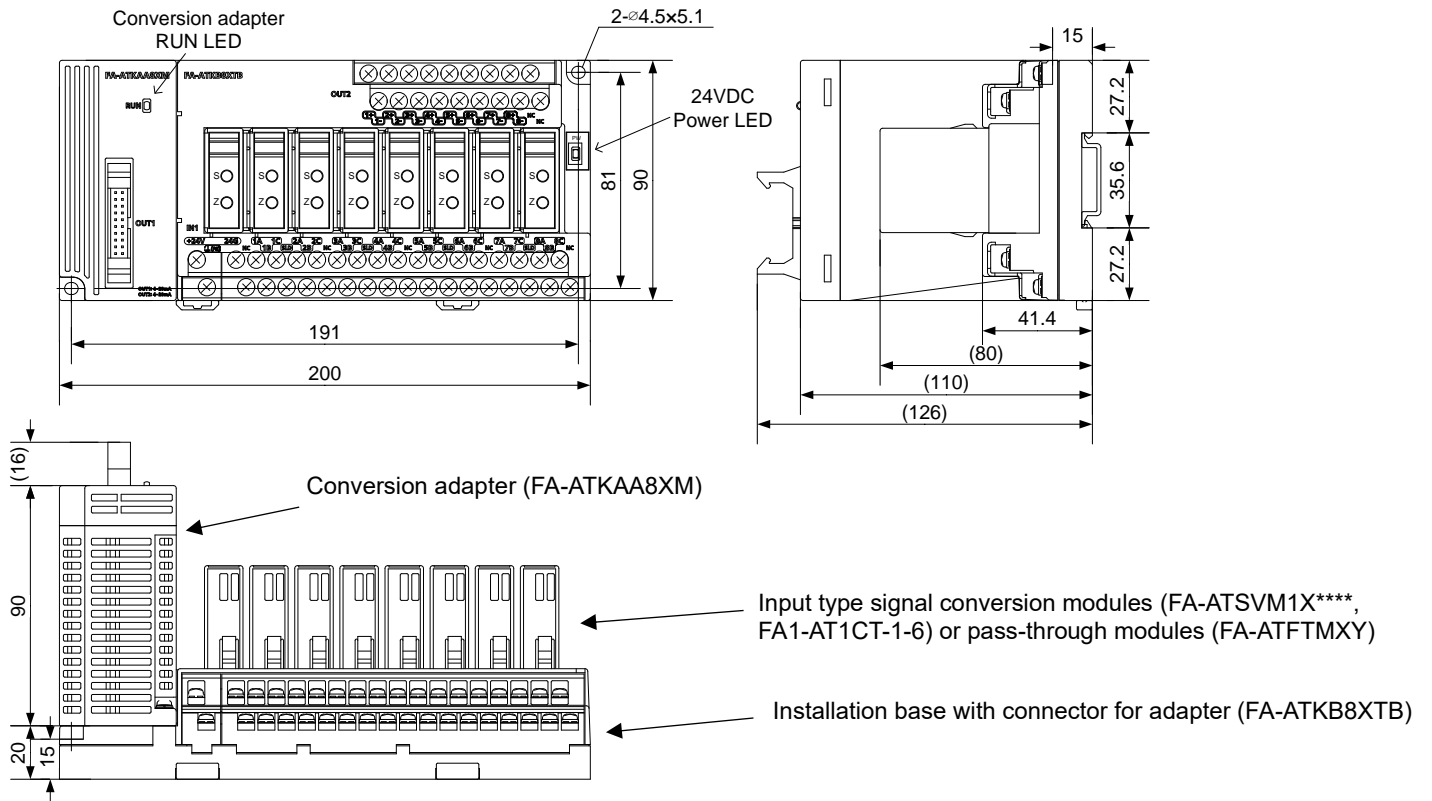

5-6. Signal conversion module (FA-ATSVM1X****), pass-through module (FA-ATFTMX)

[Unit : mm]

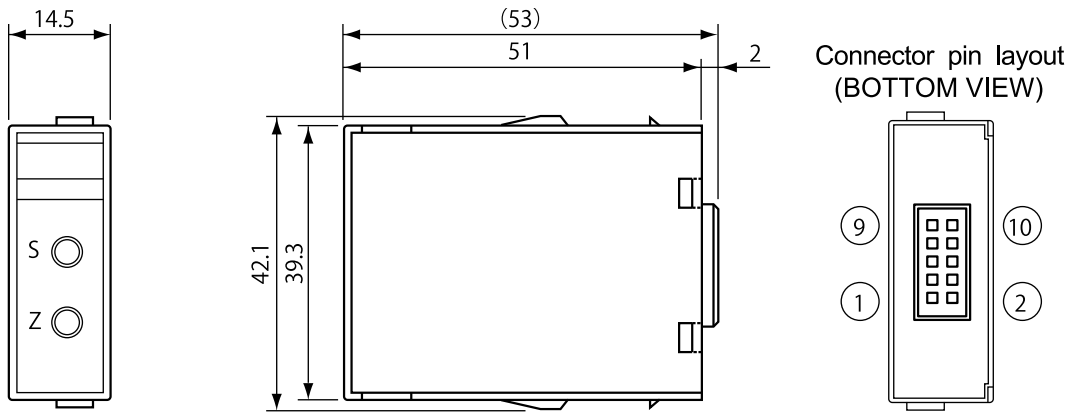

5-7. Signal conversion module (FA1-AT1CT-1-6)

[Unit : mm]

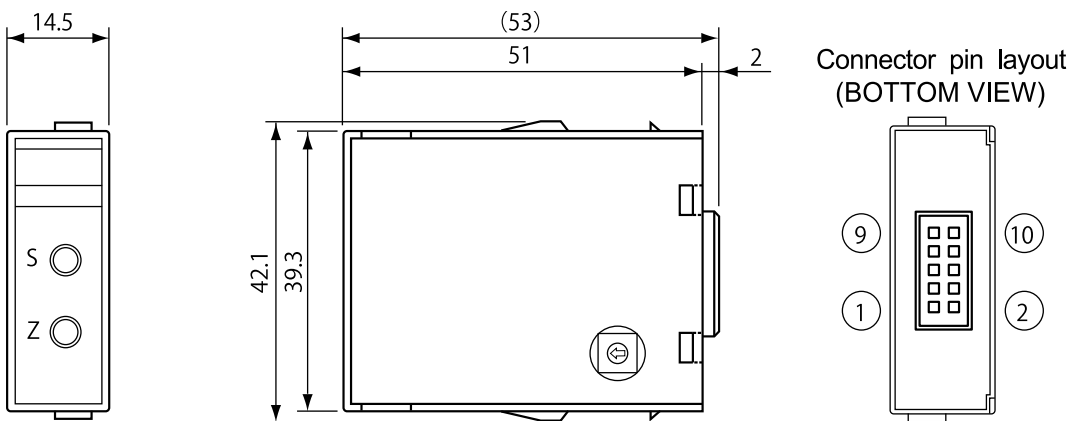

5-8. Terminal block ↔ connector conversion adapter (FA-Q6TCA)

[Unit : mm]

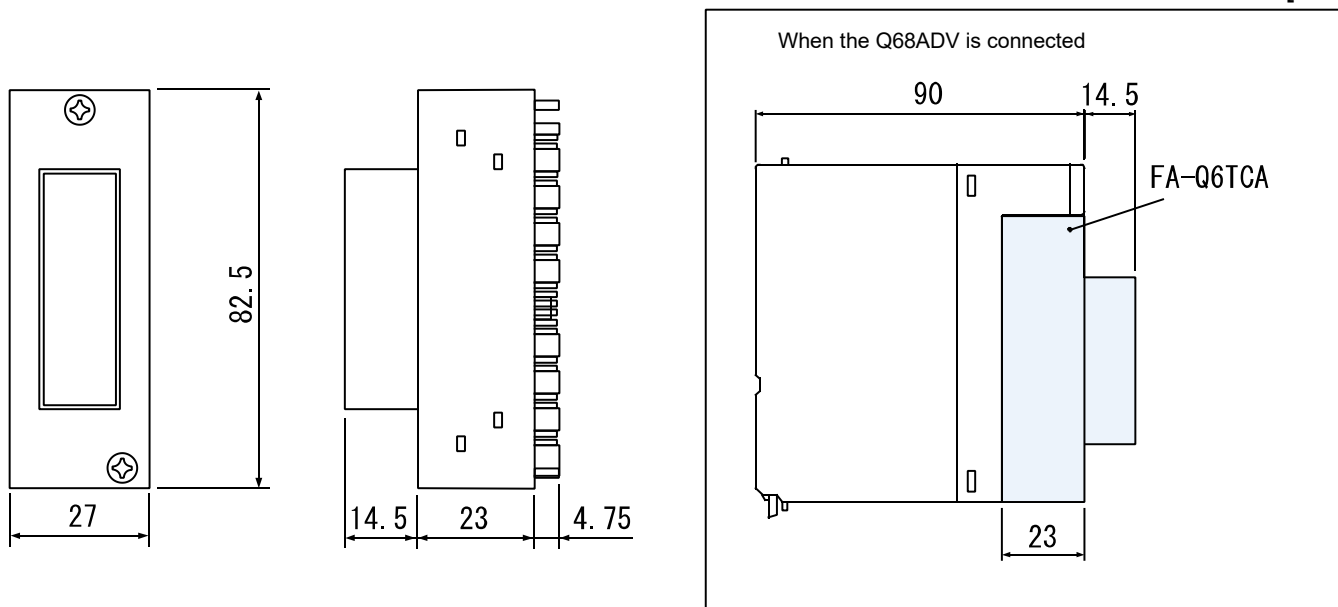

6. INSTALLATION ORIENTATION

6-1. Input type 8-channel installation base, spring clamp terminal block type (FA1-AT1B8X1TE)

Horizontal installation

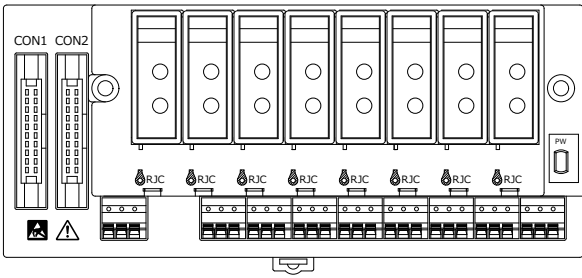

Vertical installation

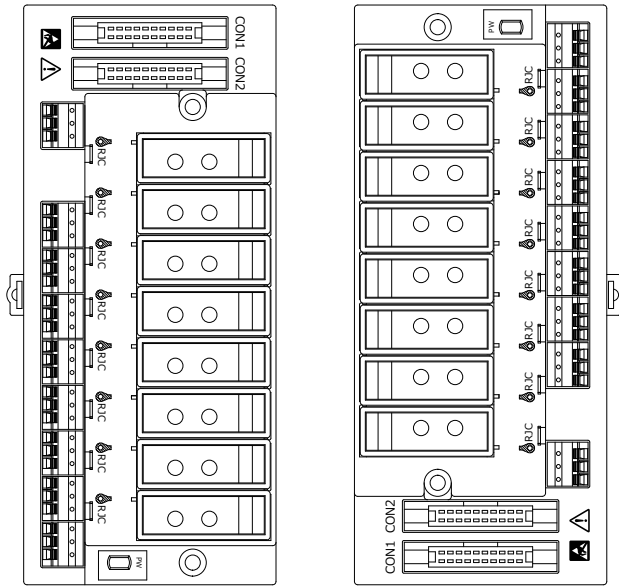

Upward installation

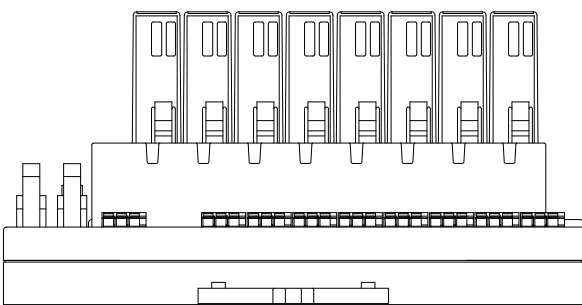

Restriction:

For vertical installation or upward installation, set the ambient temperature to 50°C or lower when using three or more distributor signal conversion modules (FA-ATSVM1XD).

6-2. Input type 8-channel installation base, screw terminal block type (FA-ATB8XTB)

Horizontal installation

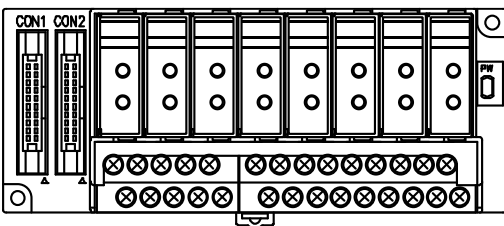

Vertical installation

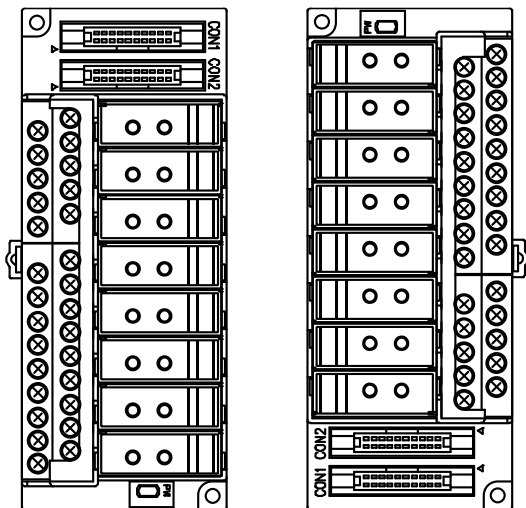

Upward installation

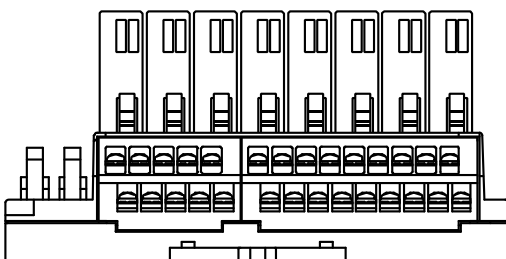

Restriction:

For vertical installation or upward installation, set the ambient temperature to 50°C or lower when using three or more distributor signal conversion modules (FA-ATSVM1XD).

6-3. Input type 4-channel installation base, spring clamp terminal block type (FA1-AT1B4X1TE)

Horizontal installation

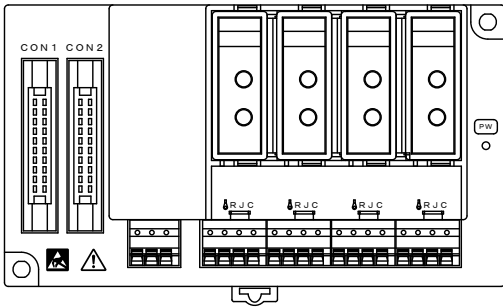

Vertical installation

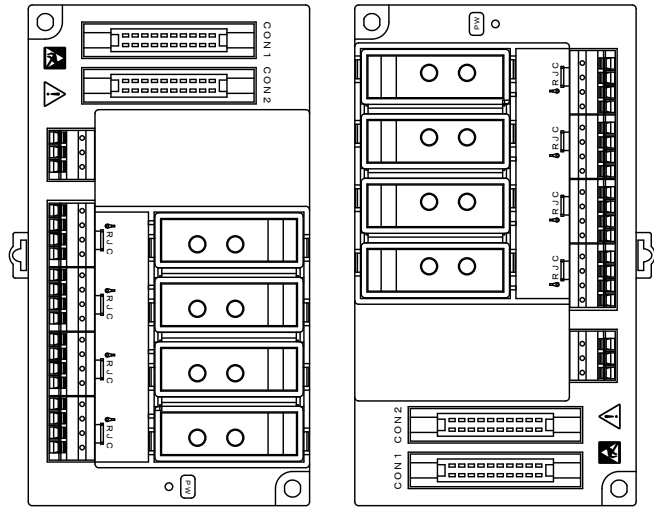

Upward installation

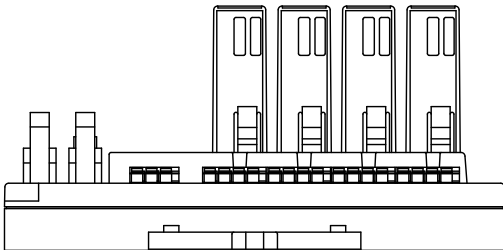

Restriction :

For vertical installation or upward installation, set the ambient temperature to 50°C or lower when using three or more distributor signal conversion modules (FA-ATSVM1XD).

6-4. Input type 4-channel installation base, terminal block type (FA1-AT1B4X1TB)

Horizontal installation

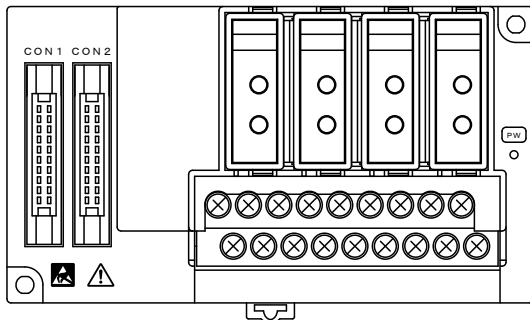

Vertical installation

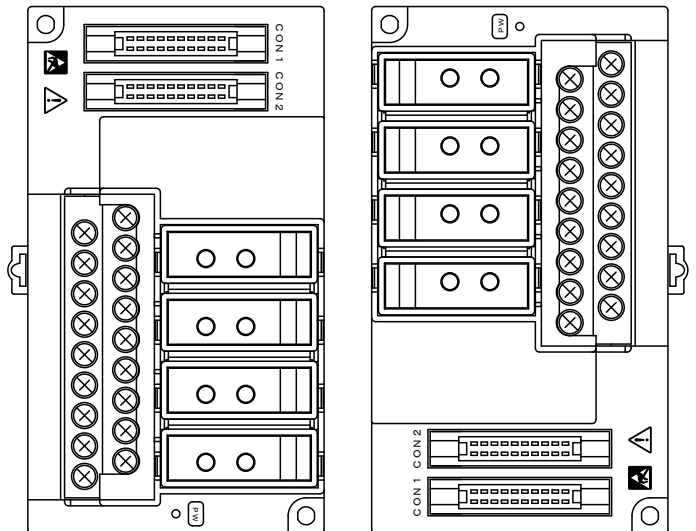

Upward installation

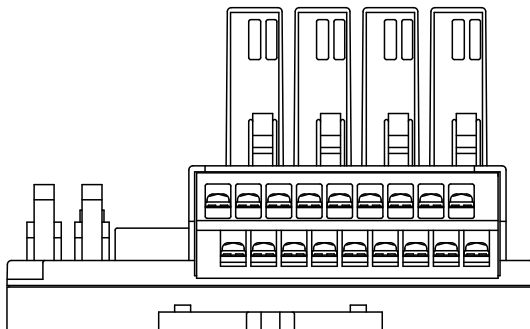

Restriction :

For vertical installation or upward installation, set the ambient temperature to 50°C or lower when using three or more distributor signal conversion modules (FA-ATSVM1XD).

6-5. Input type installation base with connector for adapter (FA-ATKB8XTB)

(1) Installation orientation

Horizontal installation

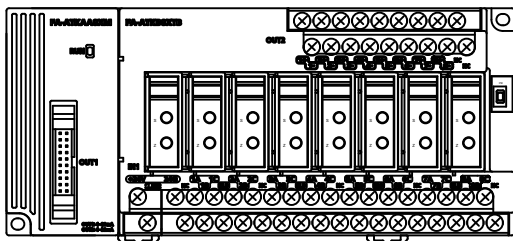

Vertical installation

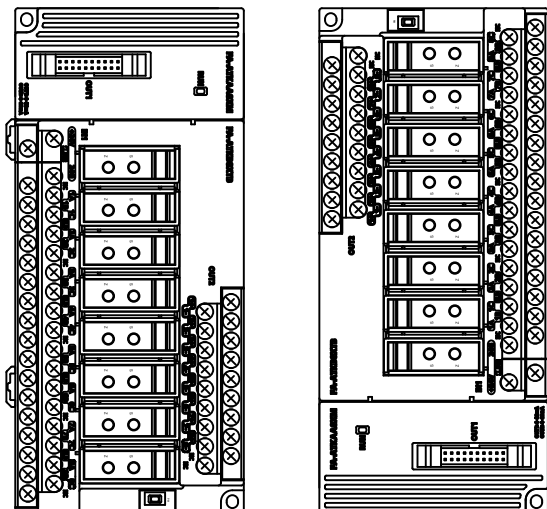

Upward installation

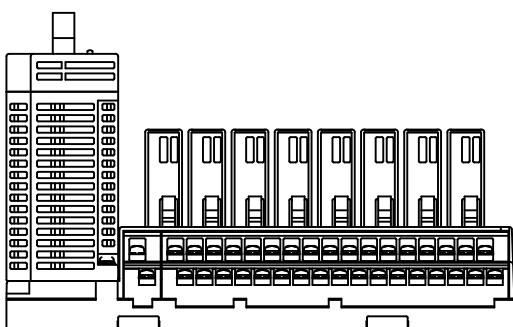

Restrictions:

- 1) For vertical installation, set the ambient temperature to 45°C or lower, or to the range shown in the graph below of the external load resistance value for output 2 and the ambient temperature. Additionally, set the ambient temperature to 50°C or lower when using three or more distributor signal conversion modules (FA-ATSVM1XD), even when the external load resistance value is 250Ω or more.

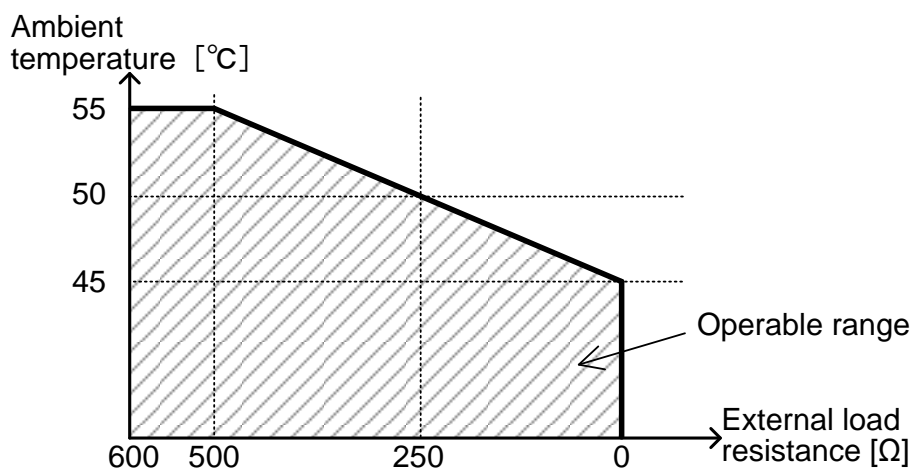

- 2) For horizontal installation, set the ambient temperature to 50°C or lower when using three or more distributor signal conversion modules (FA-ATSVM1XD).

7. CONNECTING METHOD

7-1. Installing the base unit

This section explains how to install the base unit in a control panel.

7-1-1. Installation using a DIN rail

Install the base unit on a DIN rail as shown below.

(1) Installation

- 1) Hook the upper latch of the base unit on the DIN rail.
- 2) Push the base unit against the DIN rail until it locks into place.

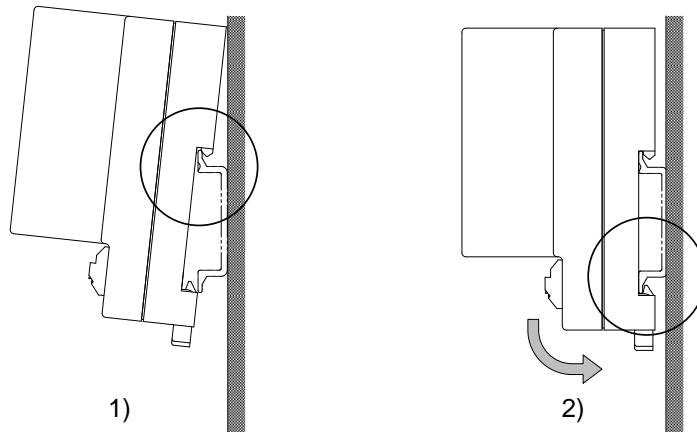

(2) Removal

- 1) Insert a flathead screwdriver into the DIN rail latch.
- 2) Push down the latch (using the lower part of the base unit as a fulcrum) to remove the unit from the DIN rail.

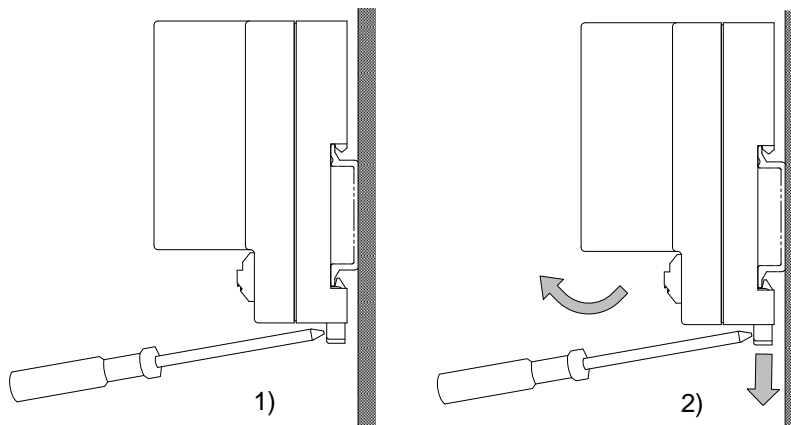

7-1-2. Installation using screws

Install screws as shown below.

1) Tighten the two screws to install the base unit into a control panel or other areas.

Item	FA1-AT1B8X1TE	FA-ATB8XTB FA1-AT1B4X1TE FA1-AT1B4X1TB FA-ATKB8XTB
Screw size	M4x0.7mmx27mm or more	M4x0.7mmx20mm or more
Tightening torque	78 to 118N·cm (8 to 12kgf·cm)	78 to 118N·cm (8 to 12kgf·cm)

■ Screw hole of FA1-AT1B8X1TE

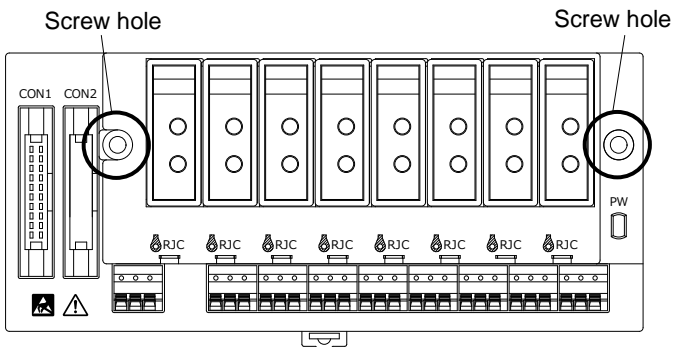

■ Screw hole of FA-ATB8XTB

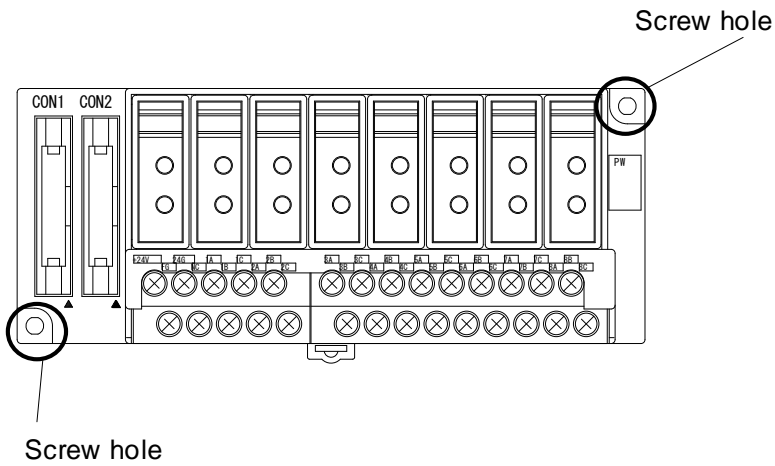

■ Screw hole of FA1-AT1B4X1TE

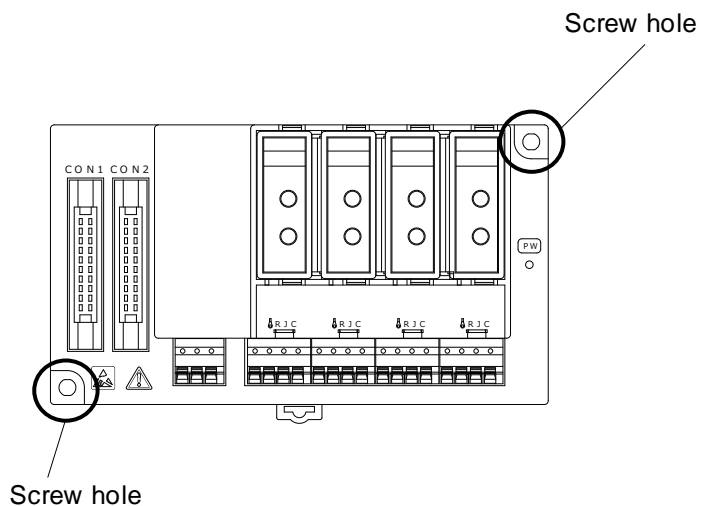

■ Screw hole of FA1-AT1B4X1TB

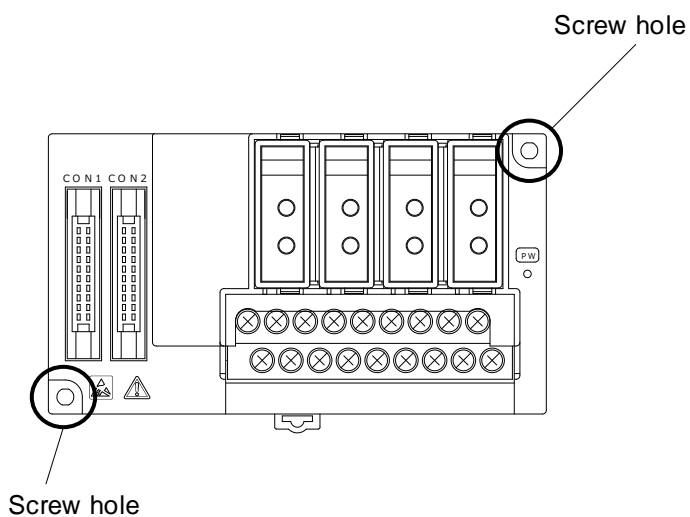

■ Screw hole of FA-ATKB8XTB

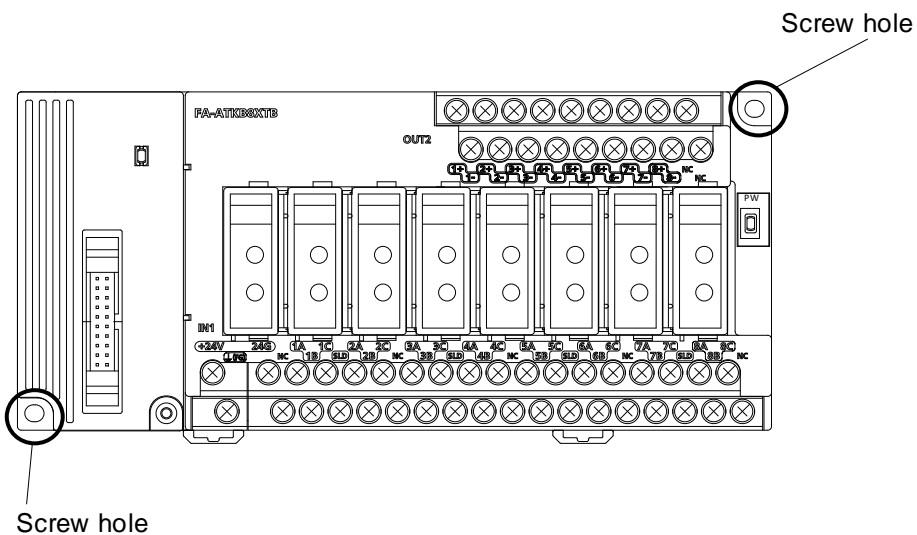

7-2. Connection example with a terminal block module of a programmable controller

7-2-1. When a cable with a terminal block is used

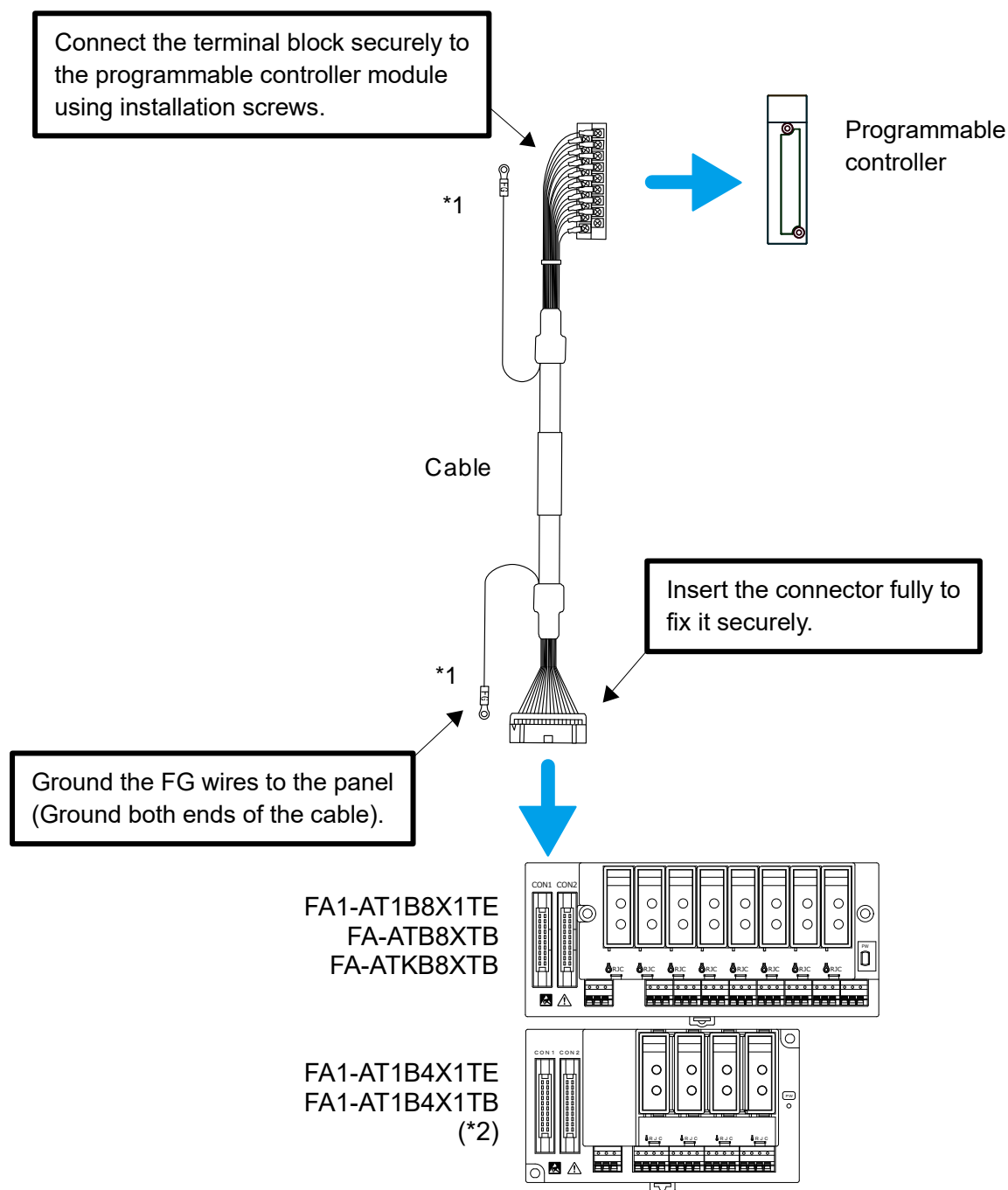

*1: Ground the cable's FG wires on the control panel.

If the values retrieved by the programmable controller vary greatly due to noise, install a ferrite core (such as the ESD-SR-250 manufactured by TOKIN Corporation) on the unshielded part of the cable.

*2: Instead of a 8-channel analog unit, two 4-channel bases can be used. To connect two bases, refer to 7-3.

7-2-2. When a terminal block to connector conversion adapter is used

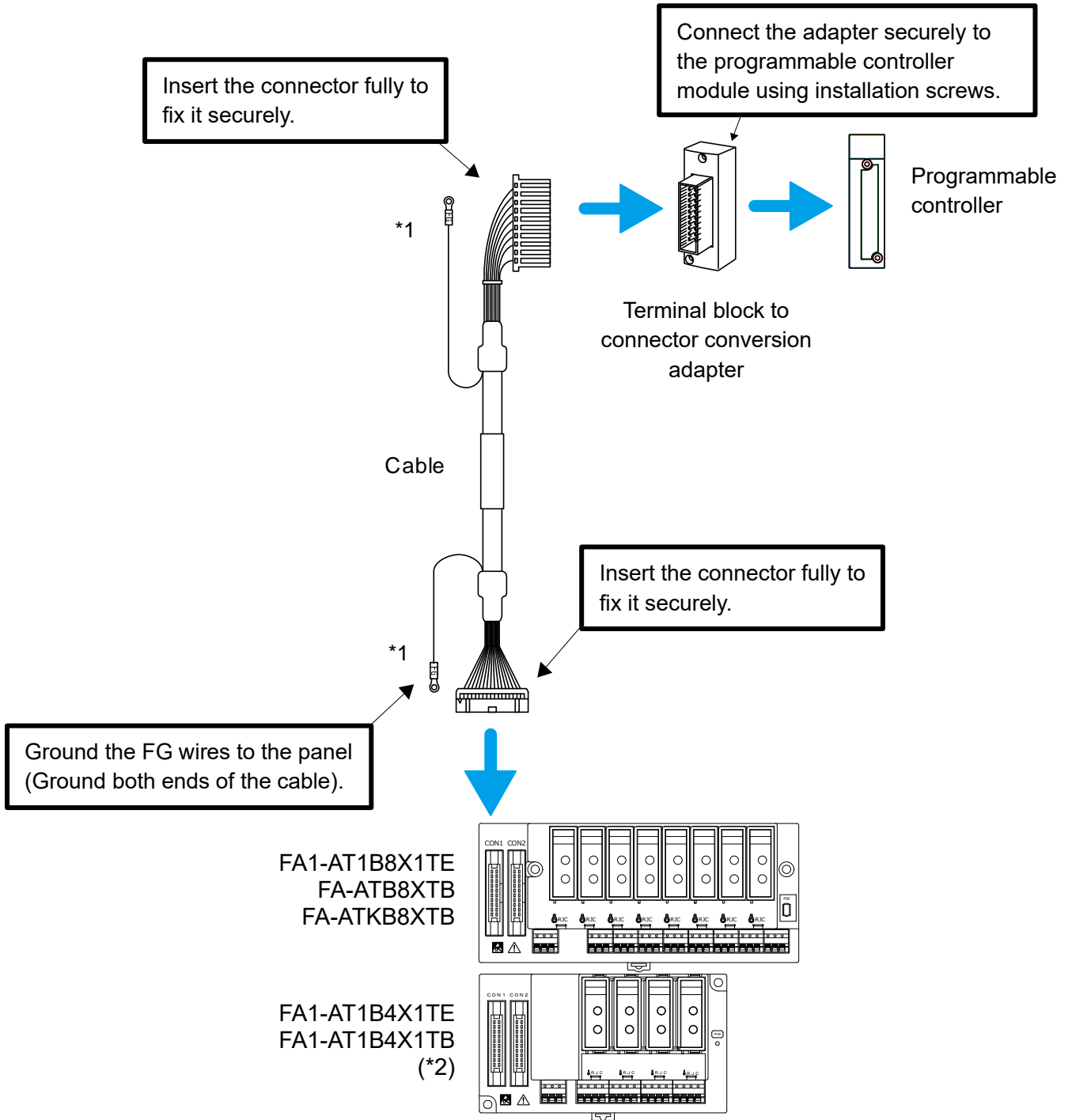

*1: Ground the cable's FG wires on the control panel.

If the values retrieved by the programmable controller vary greatly due to noise, install a ferrite core (such as the ESD-SR-250 manufactured by TOKIN Corporation) on the unshielded part of the cable.

*2: Instead of a 8-channel analog unit, two 4-channel bases can be used. To connect two bases, refer to 7-3.

7-2-3. When a discrete cable is used

CC-Link module, non-Mitsubishi programmable controller, or others

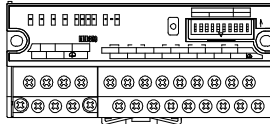

Wire the cable securely to the terminal block of the programmable controller module.

Ground the FG wires to the panel.

Insert the connector fully to fix it securely.

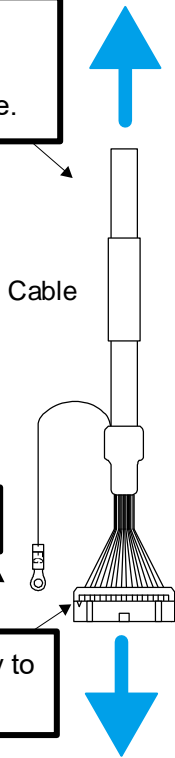

[FA-CBL**ATF pin assignment]

Signal name	Cable color	Dot	Dot color
CH1+	Pink	2	Black
CH1-		2	Red
CH2+	Yellow	2	Black
CH2-		2	Red
CH3+	White	2	Black
CH3-		2	Red
CH4+	Gray	2	Black
CH4-		2	Red
CH5+	Orange	2	Black
CH5-		2	Red
CH6+	Pink	1	Black
CH6-		1	Red
CH7+	Yellow	1	Black
CH7-		1	Red
CH8+	White	1	Black
CH8-		1	Red
NC	Gray	1	Black
NC		1	Red
FG	Orange	1	Black
FG		1	Red

FA1-AT1B8X1TE
FA-ATB8XTB
FA-ATKB8XTB

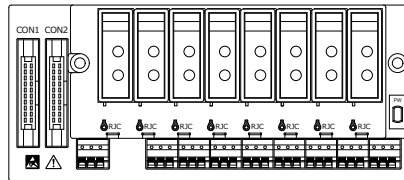

FA1-AT1B4X1TE
FA1-AT1B4X1TB
(*2)

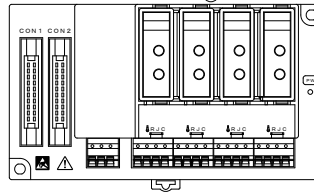

*1: Ground the cable's FG wires on the control panel.

If the values retrieved by the programmable controller vary greatly due to noise, install a ferrite core (such as the ESD-SR-250 manufactured by TOKIN Corporation) on the unshielded part of the cable.

*2: Instead of a 8-channel analog unit, two 4-channel bases can be used. To connect two bases, refer to 7-3.

7-3. Connection example when an additional 4-channel base is used

Connect the base as shown in the figure below.

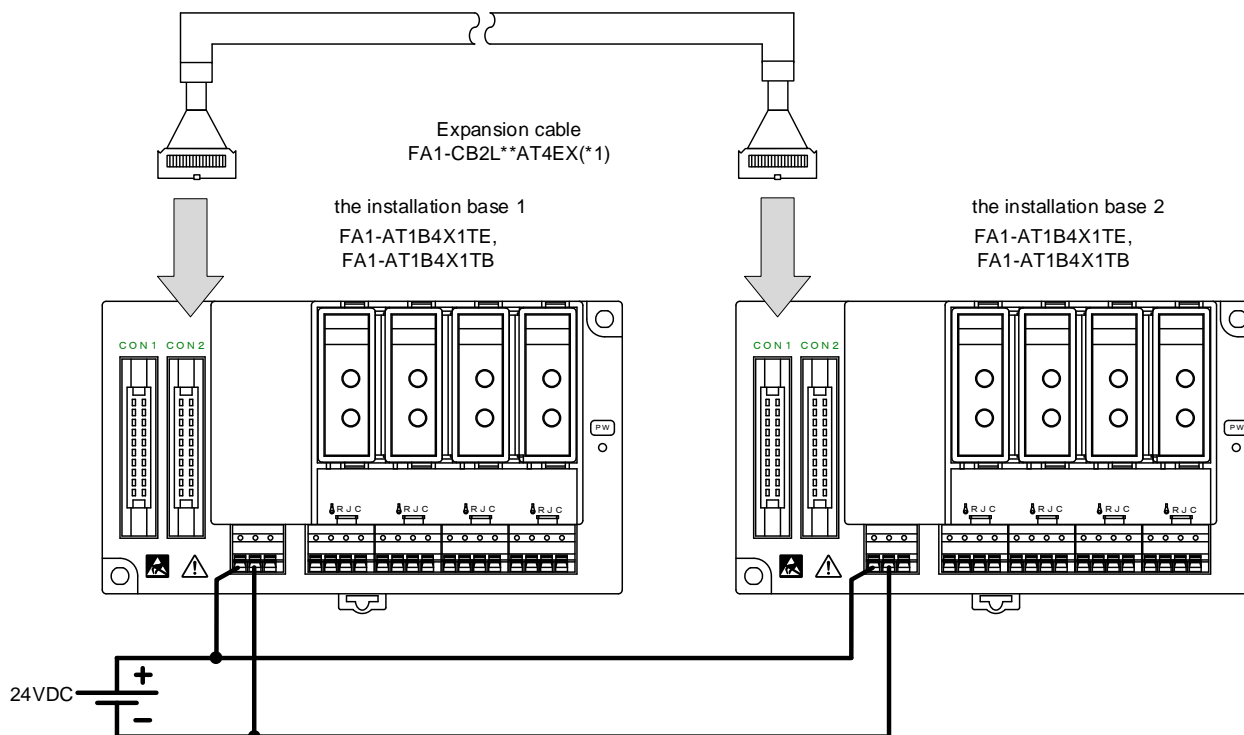

*1: When the base is added, note that CH1 to CH4 and CH5 to CH8 change places with each other. (Refer to the following table.)

Monitor display

Order of channels displayed on the monitor		
When a 8-channel base is used	When a 4-channel base is used	When two 4-channel bases are used*1
CH1	CH1	CH5
CH2	CH2	CH6
CH3	CH3	CH7
CH4	CH4	CH8
CH5	—	CH1
CH6	—	CH2
CH7	—	CH3
CH8	—	CH4

*1: When two 4-channel bases are used, channels of the added base are displayed first.

7-4. Mounting/removing a signal conversion module

(1) How to mount the module to the installation base

1) Align the signal conversion module with a slot of the installation base.

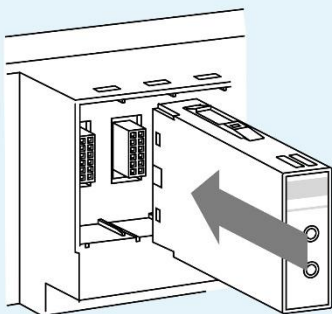

2) Insert the signal conversion module until the mounting/removing hooks are locked (until they click).

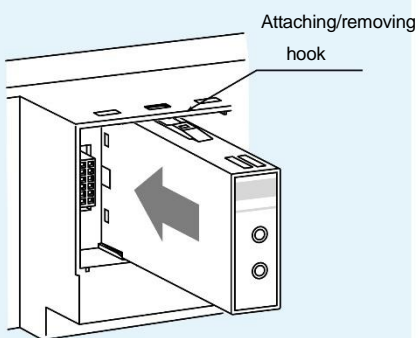

(2) How to remove the module from the installation base

1) Hold both sides of the mounting/removing hooks.

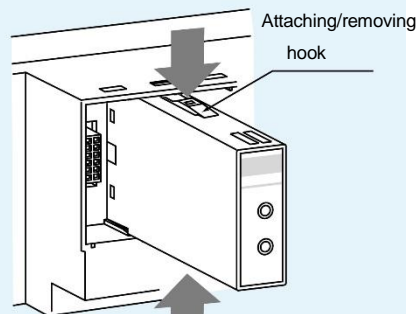

2) Pull out the signal conversion module while holding the hooks.

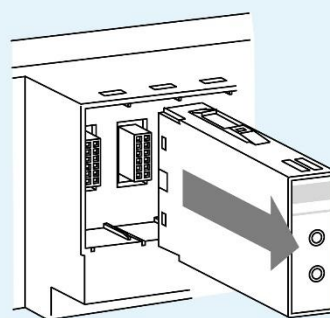

Note
Use an input type signal conversion module (the one with a purple line). Using an output type signal conversion module (the one with an orange line) incorrectly may cause failure of the products.

Points
(1) Hold the installation base, not the signal conversion module, when transporting the installation base with the signal conversion module mounted or when installing it to a panel.
(2) Mount a dummy module (FA-ATNDM) onto an empty slot of the installation base for dust prevention.

7-5. Mounting/removing a conversion adapter (FA-ATKB8XTB)

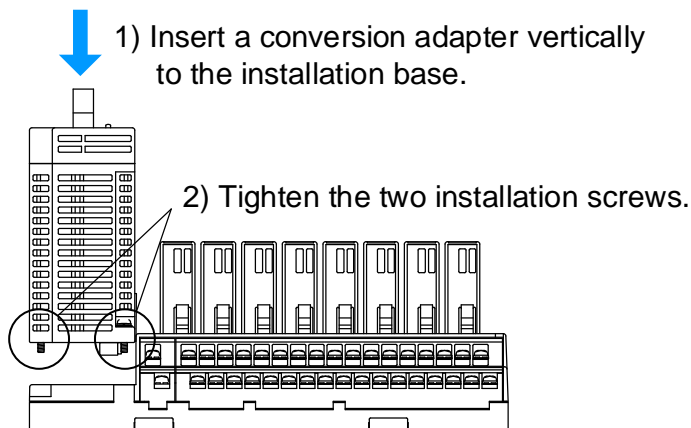

Specified tightening torque range: 36 to 48N·cm (3.7 to 4.8kgf·cm, 3.21 to 4.17lb·in)

7-6. Wiring to a spring clamp terminal block

(1) Wires routing

(a) Fabrication on cable insulator

Strip the wire as follows. If the length of the sheath peeled is too long, a short circuit may occur with neighboring wires. If the length is too short, wires might come off. Wire the stripped cable after twisting it to prevent it from becoming loose. In addition, do not solder it.

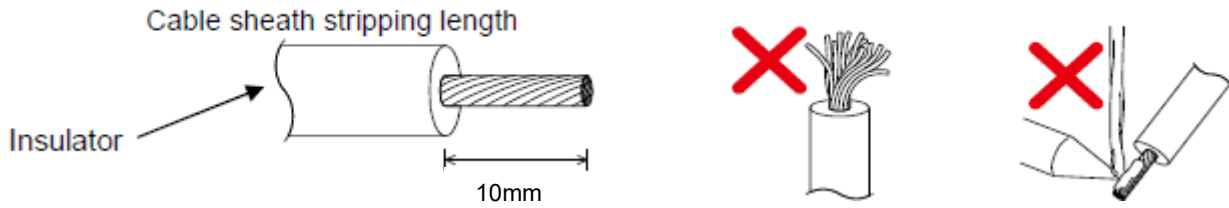

(b) Using a ferrule terminal

Insert wires to a ferrule terminal and crimp it. Make sure that core wire slightly comes out of the ferrule. Check the condition of the ferrule terminal after crimping. Do not use a ferrule terminal of which the crimping is inappropriate, or the face is damaged.

Refer to chapter 9 for the applicable ferrule terminal.

* Ferrule terminals crimped onto one wire are applicable to the terminal block of this product.

If multiple wires need to be installed (such as for the power supply), provide an external common terminal. (For example, ABCOM of a high-speed counter module or COM of a simple motion module)



(c) Inserting wires

The wire with ferrule or solid cable can be inserted into the wire insertion hole. After inserting, pull the wire lightly to confirm that the wire is surely connected.

For the ferrule terminal insertion direction, refer to the figure below.

When binding twisted wires, press the push button using the screw driver, then insert the twisted wires into the wire insertion hole.

* Make sure to insert the wire straight as far as it will go.

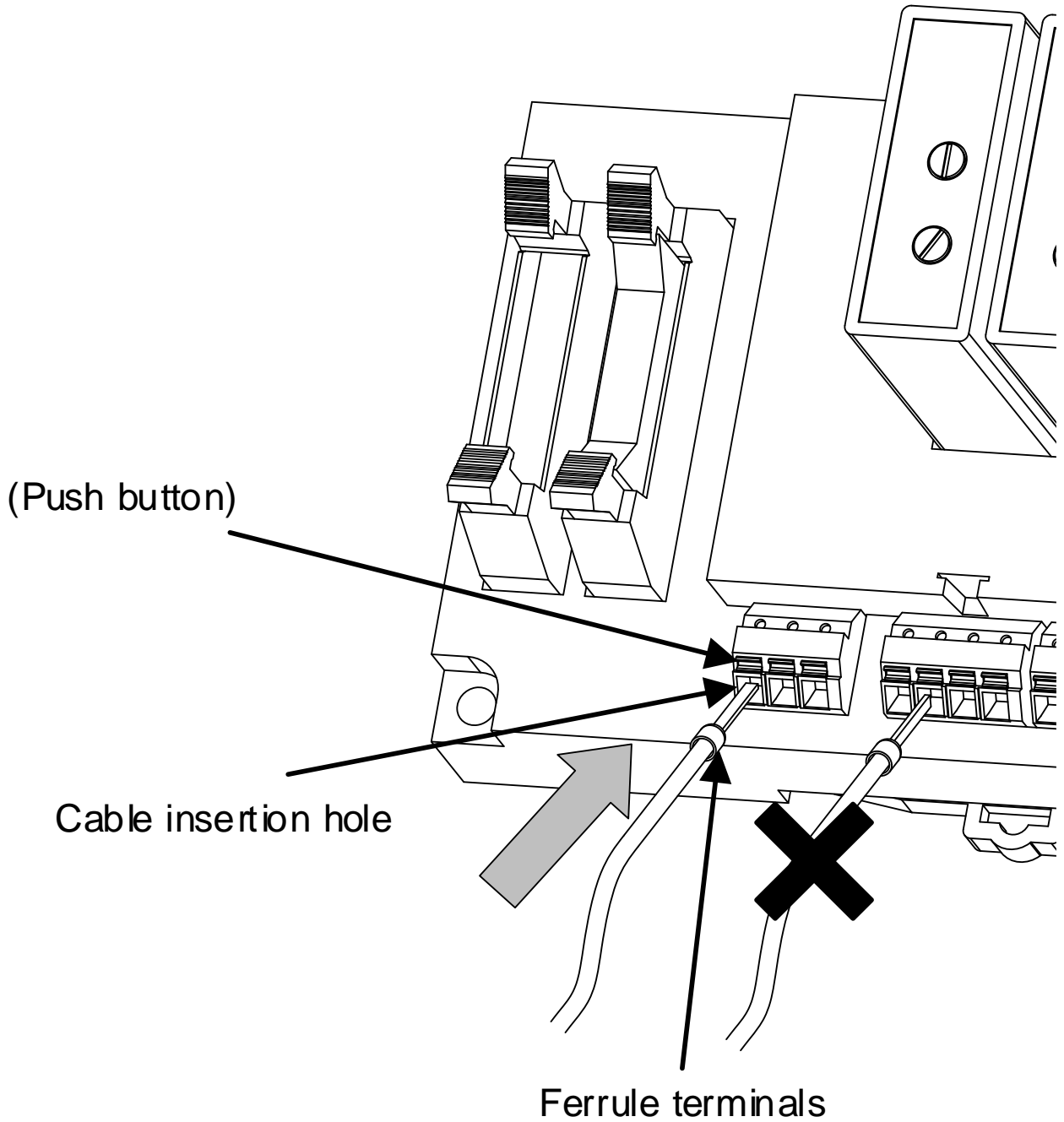

(2) Wires removal

Press the push button all the way using the screw driver, then pull out the wire.

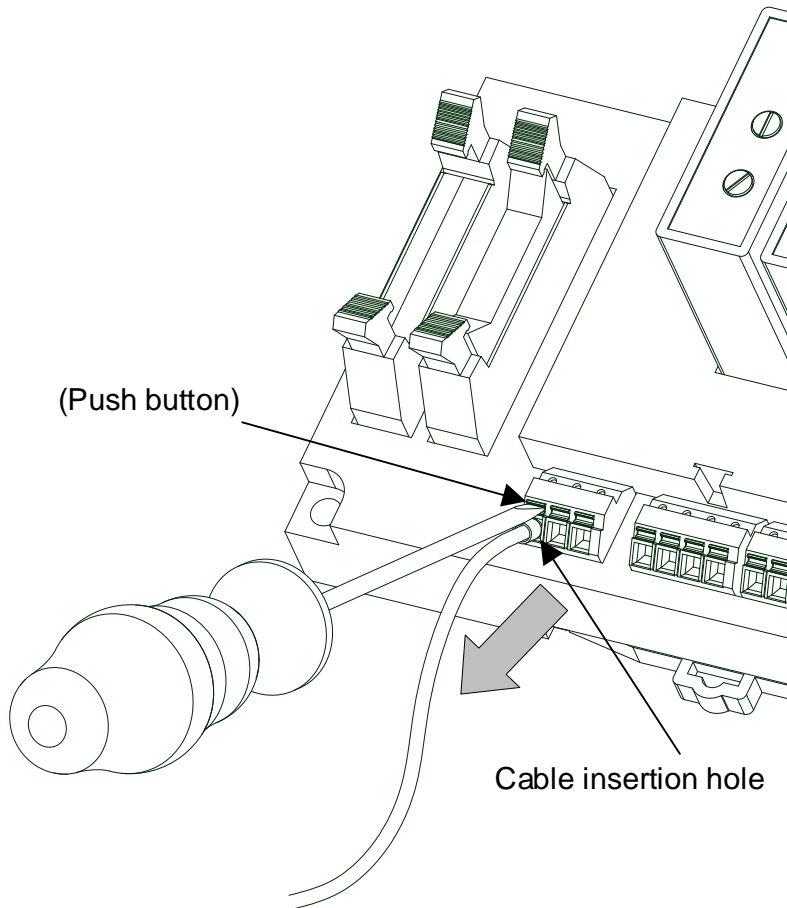

Use the screw driver shown in the table below.

Recommended tool (screw driver)		
Manufacturer	Model	Blade edge size
PHOENIX CONTACT	SZS 0,4x2,5 VDE	2.5x0.4mm

8. EXTERNAL CONNECTION

Connect external wiring as shown in the figure below. (Example for the FA-ATKB8XTB)

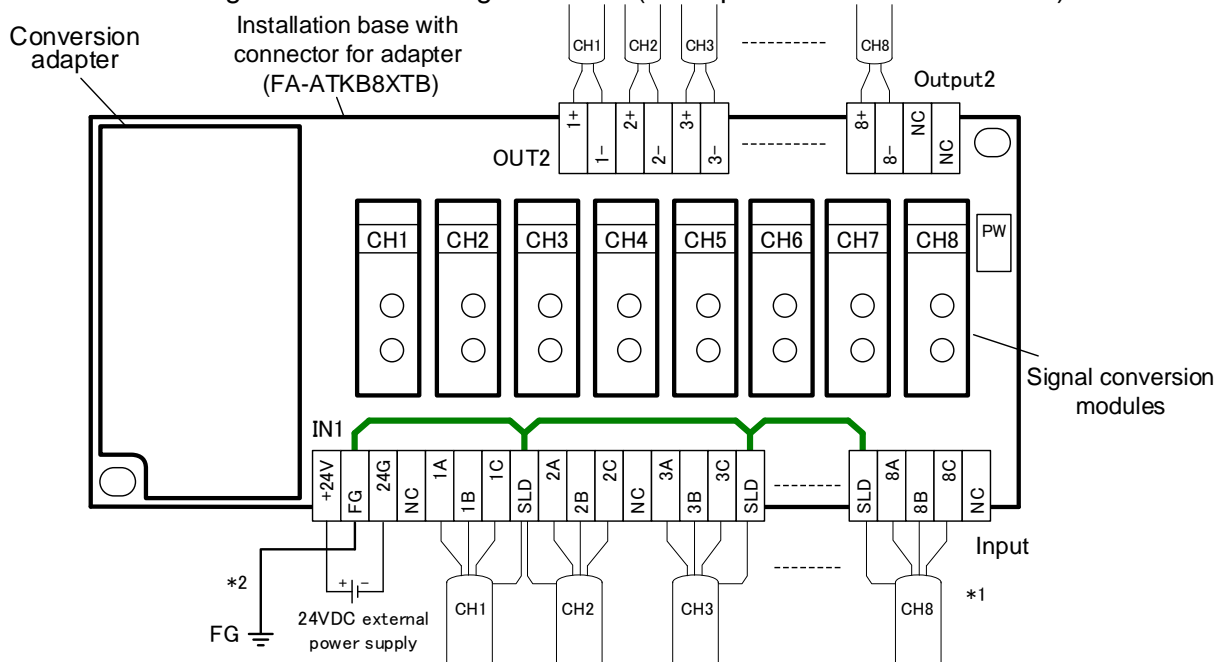

*1: Use shielded wires, and ground the shields. SLD terminals on the input terminal block (IN1) of the FA-ATKB8XTB are internally connected to the FG terminal and can be used as relay terminals to ground the shields of the external cables.

*2: Ground the FG terminal regardless of whether or not SLD terminals are used.

The wiring to the input terminal block (IN1) differs depending on the signal conversion modules and the pass-through modules to be mounted. The wiring between each signal conversion module or pass-through module and the installation base is as follows.

●Wiring diagrams between each signal conversion module or pass-through module and the installation base

<p>Voltage input (FA-ATSVM1XV****)</p> <p>Installation base with connector for adapter</p>	<p>Current input (FA-ATSVM1XA420)</p> <p>Installation base with connector for adapter</p>	<p>2-wire transmitter input (FA-ATSVM1XD)</p> <p>Installation base with connector for adapter</p>	<p>Thermocouple temperature input (FA-ATSVM1XT*)</p> <p>Installation base with connector for adapter</p>
<p>RTD input (FA-ATSVM1XR****)</p> <p>Installation base with connector for adapter</p>	<p>CT input (FA1-AT1CT-1-6)</p> <p>Installation base with connector for adapter</p>	<p>Pass-through module (FA-ATFTMX) *3</p> <p>When signals are passed through</p> <p>Installation base with connector for adapter</p> <p>When current is converted to voltage</p> <p>Installation base with connector for adapter</p>	

- *1: Connect the end (round solderless terminal) of the RJC sensor of the thermocouple temperature input signal conversion module to the terminal block. The round solderless terminal and the internal circuit of the signal conversion module are electrically insulated. Do not pull strongly, twist, or bend the RJC sensor of the thermocouple temperature input signal conversion module. Doing so may cause failure of the RJC sensor.
- *2: For FA1-AT1B8X1TE or FA1-AT1B4X1TE, fix the RJC fixing part as shown in the figure below.

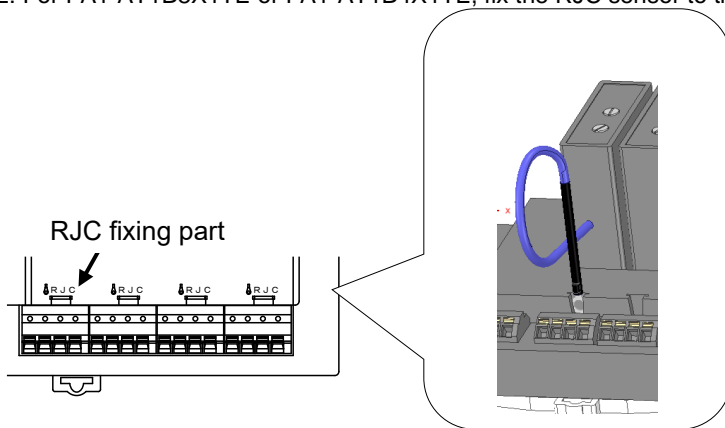

- *3: When the FA-ATKB8XTB is used, only voltage input (1 to 5V) can be used.

9. APPLICABLE SOLDERLESS TERMINALS

Type		Round		Y-shaped	
Manufacture	Applicable wire size	Non-insulated solderless terminal	Insulated solderless terminal	Non-insulated solderless terminal	Insulated solderless terminal
Nichifu Co., Ltd. NTM	0.3 to 1.25mm ²	R1.25-3N R1.25-3.5N	TG _N ^V 1.25-3N TG _N ^V 1.25-3.5N	1.25Y-3 1.25Y-3N 1.25Y-3L 1.25Y-3.5	TG _N ^V 1.25Y-3 TG _N ^V 1.25Y-3N TG _N ^V 1.25Y-3L TG _N ^V 1.25Y-3.5
	1.25 to 2.0mm ²	R2-3N	TG _N ^V 2-3N	2Y-3 2Y-3.5S	TG _N ^V 2Y-3 TG _N ^V 2Y-3.5S
Japan Solderless Terminal Mfg. Co., Ltd. JST	0.3 to 1.25mm ²	1.25-MS3	V1.25-MS3	1.25-B3A 1.25-C3A 1.25-N3A 1.25-C3.5A	V1.25-B3A V1.25-N3A
	1.25 to 2.0mm ²	2-MS3	V2-MS3	2-N3A 2-M3A	V2-N3A
Nippon Tanshi Co., Ltd. NTK	0.3 to 1.25mm ²	R1.25-3ML R1.25-3.5SL	RAV1.25-3ML RAP1.25-3ML	VD1.25-3L VD1.25-3.5SS VD1.25-3.5S	VDAV1.25-3L VDAV1.25-3.5SS VDAV1.25-3.5S
	1.25 to 2.0mm ²	R2-3SL	RAV2-3SL RAP2-3SL	VD2-3S VD2-3.5SS VD2-3.5S	VDAV2-3.5SS VDAV2-3.5S

• Solderless terminal dimensions

[Unit : mm]

Round non-insulated solderless terminal

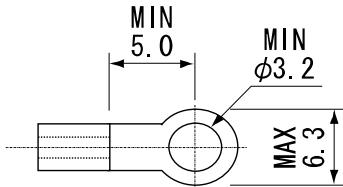

Round insulated solderless terminal

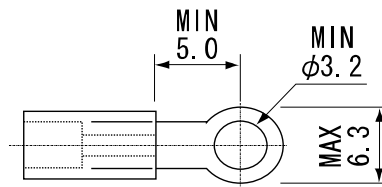

Y-shaped non-insulated solderless terminal

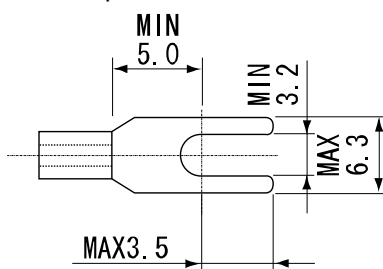

Y-shaped insulated solderless terminal

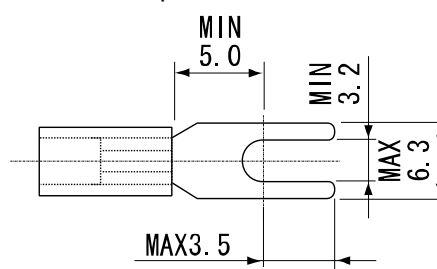

• Terminal block shape

[Unit : mm]

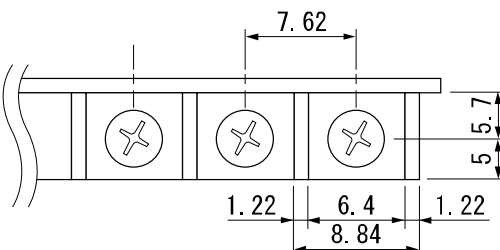

- Applicable solderless terminals (ferrule)

Type		Applicable ferrule	Crimp tool
Manufacturer	Applicable wire size		
PHOENIX CONTACT	0.25 mm ² (AWG24)	AI 0,25-10 YE	CRIMPFOX 6
	0.34 mm ² (AWG22)	AI 0,34-10 TQ	
	0.5 mm ² (AWG20)	AI 0,5-10 WH	
	0.75 mm ² (AWG18)	AI 0,75-10 GY	
	1.0 mm ² (AWG18)	AI 1-10 RD	
	1.5 mm ² (AWG16)	AI 1,5-10 BK	

10. PERCAUTIONS

- (1) Allow the product to warm up for 10 minutes or more to satisfy accuracy specifications of the product.
- (2) Since the signal conversion module had been calibrated at the factory, calibration at the site is not necessary. However, when the calibration is required for the conformity between the signal conversion module and other connected device, make the zero/span adjustment as follows:
(Trimmer operation . . . Turn to the right (in clockwise) for increasing a value,
Turn to the left (in counterclockwise) for decreasing a value)
 - 1) Allow the product to warm up for 10 minutes or more after powering it on.
 - 2) Input the signal equivalent to 0% in the input range, and adjust output signal to 0% by using the zero adjustment trimmer.
 - 3) Input the signal equivalent to 100% in the input range, and adjust output signal to 100% by using the span adjustment trimmer.
 - 4) Complete the zero/span adjustment by repeating the operation in Step 2 and 3.
 - 5) Input the signal of 25%, 50%, and 75% in the input range, and check the output linearity.

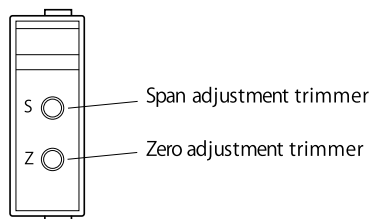

- (3) Since the conversion adapter had been calibrated at the factory, it is not necessary to be calibrated. When the calibration is required for the conformity between the conversion adapter and other connected device, make the zero/span adjustment on the signal conversion module.

11. WARRANTY

Please confirm the following product warranty details prior to product use.

1. Gratis Warranty Term and Gratis Warranty Coverage

If any faults or defects (hereinafter "Failure") found to be the responsibility of Mitsubishi Electric Engineering Company Limited (hereinafter "MEE") occurs during use of the product within the gratis warranty term, the product shall be repaired at no cost via the distributor from whom you made your purchase.

[Gratis Warranty Term]

The gratis warranty term of the product shall be for one (1) year after the date of purchase or delivery to a designated place. Note that the maximum distribution period shall be six (6) months, and the gratis warranty term after shipment from MEE shall be limited to eighteen (18) months.

Additionally, the gratis warranty term for repaired product shall not exceed the gratis warranty term of the product prior to repair.

[Gratis Warranty Coverage]

- (1) The gratis warranty Coverage shall be limited to normal use within the usage state, methods and environment, etc., which follow the conditions and precautions, etc., given in the instruction manual, user's manual and caution labels on the product.
- (2) Even within the gratis warranty term, repairs shall be charged for in the following cases.
 - 1) Failure occurring from inappropriate storage or handling, carelessness or negligence by the user, or Failure caused by the user's hardware or software design.
 - 2) Failure caused by unapproved modifications, etc., to the product by the user.
 - 3) When the MEE product is assembled into a user's device, Failure that could have been avoided if functions or structures, judged as necessary in the legal safety measures the user's device is subject to or as necessary by industry standards, had been provided.
 - 4) Failure that could have been avoided if consumable parts designated in the instruction manual had been correctly serviced or replaced.
 - 5) Failure caused by external irresistible forces such as fires or abnormal voltages, and Failure caused by force majeure such as earthquakes, lightning, wind and water damage.
 - 6) Failure caused by reasons unpredictable by scientific technology standards at the time of shipment from MEE.
 - 7) Any other failure found not to be the responsibility of MEE or that admitted not to be so by the user.

2. Paid Repair Term after Production Discontinuation

- (1) MEE shall offer product paid repair services for seven (7) years after production of the product has been discontinued. Discontinuation of production shall be reported via distributors.
- (2) Product supply (including spare parts) is not possible after production has been discontinued.

3. Overseas Service

Please consult your dealer where you purchased the products.

4. Exclusion of Opportunity Loss and Secondary Loss from Warranty Liability

Regardless of the gratis warranty term, MEE shall not be liable for compensation for damages arising from causes not attributable to MEE, opportunity losses or lost profits incurred by the user due to Failures of the products, damages or secondary damages arising from special circumstances, whether foreseen or unforeseen by MEE, compensation for accidents, compensation for damages to products other than the products, or compensation for replacement work, readjustment of onsite machinery and equipment, startup test runs or other duties carried out by the user.

5. Changes in Product Specifications

The specifications given in the catalogs, user's manuals, and technical documents are subject to change without notice.

12. TRADEMARKS

MELSEC, MELSEC iQ-R, MELSEC iQ-F, CC-Link, CC-Link IE, CC-Link IE Field, CC-Link IE TSN and CC-Link/LT are trademarks or registered trademarks of Mitsubishi Electric Corporation. Other company names and product names in the text are trademarks or registered trademarks of each company.

In some cases, trademark symbols such as '™' or '®' are not specified in this manual.



FOR SAFE OPERATIONS

- This product has been manufactured as a general-purpose part for general industries, and has not been designed or manufactured to be incorporated in a device or system used in purposes related to human life.
- Before using the product for special purposes such as nuclear power, electric power, aerospace, medicine or passenger movement vehicles, consult with Mitsubishi Electric Engineering.
- This product has been manufactured under strict quality control. However, when installing the product where major accidents or losses could occur if the product fails, install appropriate backup or failsafe functions in the system.

MITSUBISHI ELECTRIC ENGINEERING COMPANY LIMITED

NAGOYA ENGINEERING OFFICE | 1-9, Daiko-Minami, 1-Chome, Higashi-ku, Nagoya, Aichi 461-0047 Japan
Phone +81-52-6495 URL:<https://www.mitsubishielectricengineering.com/>

50D-FA9010-122-H(2510)MEE

New Publication effective Oct. 2025
Specifications subject to change without notice.