

Mitsubishi Electric Programmable Controller

Upgrade Tool

Conversion Adapter Anchor Base

Model

ERNT-1CR12F
ERNT-1CR10F
ERNT-1CR8F

User's Manual



50CM-D180423-C(2007)

MITSUBISHI ELECTRIC ENGINEERING COMPANY LIMITED

HEAD OFFICE: Huiic KUDAN BLDG.1-13-5, KUDANKITA CHIYODA-KU, TOKYO 102-0073, JAPAN
NAGOYA ENGINEERING OFFICE: 139 SHIMOYASHIKICHO-SHIMOYASHIKI, KASUGAI, AICHI 486-0906, JAPAN

SAFETY PRECAUTIONS

(Always read these precautions prior to use)

Before using this product, please read this manual carefully and pay full attention to safety to ensure that the product is used correctly.

The precautions presented in this manual are concerned with this product only. For Programmable Controller system safety precautions, refer to "Safety Guidelines" for MELSEC iQ-R Series Modules.

If the equipment is used in a manner not specified by the manufacturer, the protection provided by the equipment may be impaired.

In this manual, the safety precautions are ranked as "WARNING" and "CAUTION."



Indicates that incorrect handling may cause hazardous conditions, resulting in death or severe injury.

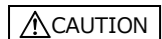

Indicates that incorrect handling may cause hazardous conditions, resulting in medium or minor injury and/or property damage.

Note that failure to observe the CAUTION level instructions may lead to a serious consequence according to the circumstances. Always follow the precautions of both levels because they are important to personal safety.

Please keep this manual in an easy-to-access location for future reference, and be sure to provide the manual to the end user.

[Installation Precautions]

WARNING

- Be sure to shut off all phases of the external power supply before performing installation work. Failure to do so could result in electric shock or product damage.

CAUTION

- Use the conversion adapter anchor base in the environment described in the general specifications in "Safety Guidelines" for MELSEC iQ-R Series Modules. Failure to do so could lead to electric shock, fire, malfunction or product failure or deterioration.
- Fully secure the conversion adapter anchor base using the installation screws, and tighten the installation screws securely within the specified torque range. Failure to do so could cause the product to fall, resulting in damage.

[Startup and Maintenance Precautions]

WARNING

- Be sure to shut off all phases of the external power supply before cleaning and retightening the installation screws. Failure to do so could lead to electric shock. Excessively tightened screws could result in damage, causing the product to fall, a short circuit or product malfunction.

[Disposal Precautions]

CAUTION

- When disposing of the product, treat it as industrial waste.

安全注意事项

(使用前请务必阅读)

使用本产品时, 请仔细阅读本手册, 并充分注意安全, 正确地使用产品。本手册中标注的注意事项仅记载了与本产品相关的内容。关于可编程控制器系统的安全事项, 请参阅所使用的MELSEC-Q系列CPU模块的用户手册。请勿在所记载内容的范围外使用, 否则会损坏产品的保护功能。

在本安全注意事项中, 安全注意事项的等级分为「警告」和「注意」。



警告 表示错误操作可能造成危险后果, 引起死亡或重伤事故。



注意 表示错误操作可能造成危险后果, 引起中度伤害, 轻伤及财产损失。

另外, 根据情况不同, 即使是注意中记载的事项, 也可能引发严重后果。不管哪个记载的都是非常重要的内容, 请务必遵守。请妥善保管本手册, 以便需要时取阅, 并将本手册交给最终用户。

【安装注意事项】

警告

- 必须将外部供应全相断开后再进行安装作业等。如果未全相断开, 可能会导致触电或产品损坏。

注意

- 应在 MELSEC iQ-R 系列“安全使用”中记载的通用规格环境下使用转换适配器固定台。如果在一般规格范围以外的环境中使用, 可能导致触电、火灾、误动作、产品的损坏或劣化。
- 转换适配器固定台应通过安装螺栓切实地加以固定, 安装螺栓应在规定的扭矩范围内切实地拧紧。可能因掉落而导致破损。

【启动和维护注意事项】

警告

- 在清扫或重新紧固端子螺栓时, 必须将外部供应全相断开后再进行。如果未全相断开, 可能会导致触电。如果螺栓拧得过紧, 可能会导致转换适配器或输入/输出模块的破损从而导致掉落、短路或误动作。

【废弃注意事项】

注意

- 废弃时请将本产品作为工业废弃物处理。

1. Overview

This manual describes specifications, handling and other information on the Mitsubishi Electric Programmable Controller Upgrade Tool Conversion Adapter Anchor Base (ERNT-1CR12F, ERNT-1CR10F, ERNT-1CR8F) that secures the bottom of the Conversion Adapter. Before attempting to make a switch from SYMAC C Series to MELSEC iQ-R Series in your installation, consult the user's manual supplied with individual module under the latter series to learn about how they differ in various aspects including performance and function.

Once you have opened the packaging, verify that it contains the following products.

Product	Shape	Qty
Conversion Adapter Anchor Base		1
Conversion Adapter Anchor Base installation screw (M4 x 8)		3
This manual	-	1

2. Specifications

The Conversion Adapter Anchor Base secures the bottom of the Conversion Adapter and is required for Conversion Adapter use. One anchor base is required per base.

Conversion Adapter Anchor Base Model	Specifications		Weight (g)
	Type		
ERNT-1CR12F	12-slot Conversion Adapter Anchor Base	For Main/Extension base unit	785
ERNT-1CR8F	8-slot Conversion Adapter Anchor Base		545
ERNT-1CR10F	10-slot Conversion Adapter Anchor Base	For Extended temperature range main/extension base unit	785

3. Mounting and Installation

3.1 Handling Precautions

- Fully secure the conversion adapter anchor base using the installation screws, and tighten the installation screws securely within the specified torque range. Failure to do so could cause the product to fall, resulting in damage.
- Do not drop or apply heavy impact to the conversion adapter anchor base. Doing so could result in damage.

3.2 Installation Environment

The installation environment is the same as MELSEC iQ-R series CPU Module to use. Refer to "Safety Guidelines" of the MELSEC iQ-R series.

4. Installation Method

MELSEC iQ-R Series Base Unit Conversion Adapter Anchor Base	R312B	R38B	R35B R33B	R612B	R68B	R65B	R310B-HT	R610B-HT
ERNT-1CR12F	○	×	×	○	×	×	×	×
ERNT-1CR8F	○	○	×	○	○	×	×	×
ERNT-1AR5F *1	×	○	○	×	○	○	×	×
ERNT-1CR10F	×	×	×	×	×	×	○	○

○ : Applicable, × : Not applicable

*1: A conversion adapter anchor base for replacing MELSEC-A series with MELSEC iQ-R series must be used. Refer to the ERNT-1AR□□F user's manual (50CM-D180317).

4.1 Installation with Base Adapter (Sold Separately)

Screw hole machining (M4 × three positions) is not required to mount the Conversion Adapter Anchor Base.

Use the screw holes of the base adapter to mount the Conversion Adapter Anchor Base.

Refer to the instruction manual of the Base Adapter for the detail about the installation position.

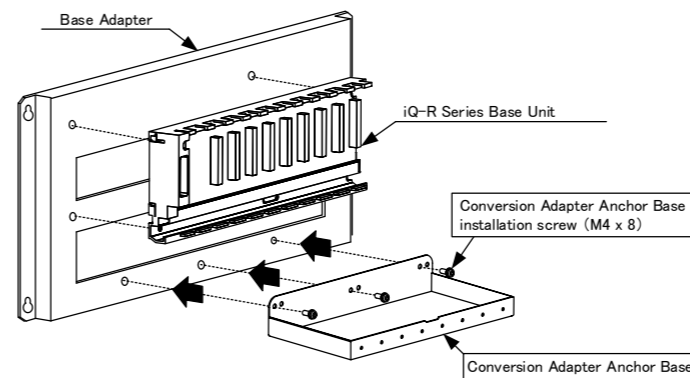

4.2 Installation without Base Adapter (Sold Separately)

Screw hole machining (M4 × three positions) is required to mount the Conversion Adapter Anchor Base.

(1) With Main Base Unit R312B, R38B, R310B-HT

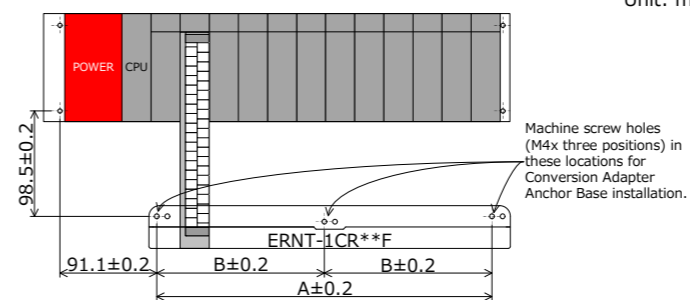

Conversion Adapter Anchor Base	Size (mm)	
	A	B
ERNT-1CR12F	315.6	157.8
ERNT-1CR10F	202.8	101.4
ERNT-1CR8F	202.8	101.4

(2) With Extension Base Unit R612B, R68B, R610B-HT

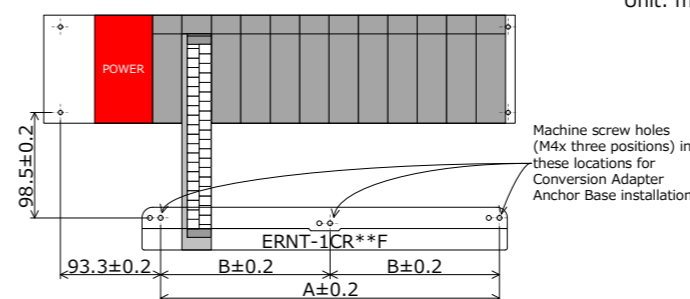

Conversion Adapter Anchor Base	Size (mm)	
	A	B
ERNT-1CR12F	315.6	157.8
ERNT-1CR10F	202.8	101.4
ERNT-1CR8F	202.8	101.4

4.3 Tightening Torque

Tighten the installation screws to the specified torque below. An inappropriate tightening torque could cause the product to fall or result in a short circuit, product failure or malfunction.

Screw Location	Tightening Torque Range
Conversion adapter anchor base installation screw (M4 screw)	1.39 to 1.89 N·m

5. External Dimensions

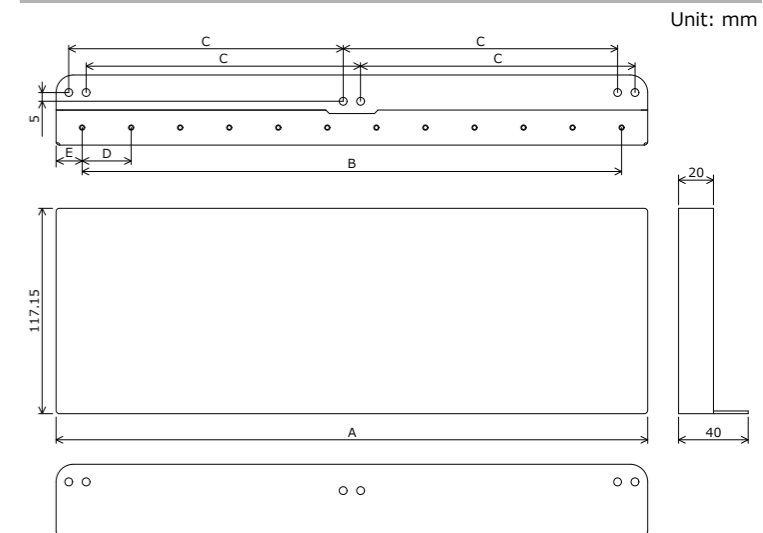

Model	A	B	C	D	E
ERNT-1CR12F	340.2	310.2	157.8	28.2	15
ERNT-1CR8F	227.4	197.4	101.4		
ERNT-1CR10F	340.2	295.2	157.8	32.8	24.2

Duplication Prohibited
This manual may not be reproduced in any form, in part or in whole, without written permission from Mitsubishi Electric Engineering Company Limited.
©2018(2019) MITSUBISHI ELECTRIC ENGINEERING COMPANY LIMITED ALL RIGHTS RESERVED

MELSEC and MELSEC iQ-R is a registered trademark of Mitsubishi Electric Corporation in Japan.
ERNT is a registered trademark of Mitsubishi Electric Engineering Company Limited in Japan.
All company and product names herein are either trademarks or registered trademarks of their respective owners.

Product Warranty Details

Please confirm the following product warranty details prior to product use.

Gratis Warranty Terms and Gratis Warranty Range

If any fault or defect (hereinafter referred to as "Failure") attributable to Mitsubishi Electric Engineering Company Limited (hereinafter referred to as "MEE") should occur within the gratis warranty period, MEE shall repair the product free of charge via the distributor from whom you made your purchase.

Gratis Warranty Period

The gratis warranty period of this product shall be one (1) year from the date of purchase or delivery to the designated place.

Note that after manufacture and shipment from MEE, the maximum distribution period shall be six (6) months, and the gratis warranty period after manufacturing shall be limited to eighteen (18) months.

In addition, the gratis warranty period for repaired products shall not exceed the gratis warranty period established prior to repair.

Gratis Warranty Range

The gratis warranty range shall be limited to normal use based on the usage conditions, methods and environment, etc., defined by the terms and precautions, etc., given in the instruction manual, user's manual and caution labels on the product.

Warranty Period after Discontinuation of Production

(1) MEE shall offer product repair services (fee applied) for seven (7) years after production of the product has been discontinued. Discontinuation of production shall be reported via distributors.

(2) Product supply (including spare parts) is not possible after production has been discontinued.

Exclusion of Opportunity Loss and Secondary Loss from Warranty Liability

Regardless of the gratis warranty period, MEE shall not be liable for compensation for damages arising from causes not attributable to MEE, opportunity losses or lost profits incurred by the user due to Failures of MEE products, damages or secondary damages arising from special circumstances, whether foreseen or unforeseen by MEE, compensation for accidents, compensation for damages to products other than MEE products, or compensation for other work carried out by the user.

Changes in Product Specifications

The specifications given in the catalogs, manuals and technical documents are subject to change without notice.

This document is a new publication, effective July 2020. Specifications are subject to change without notice.