

Mitsubishi Electric Programmable Controller

Renewal Tool

Conversion Adapter

Model

ERNT-2CR216X218X

User's Manual



50CM-D180383-B(2007)

MITSUBISHI ELECTRIC ENGINEERING COMPANY LIMITED

HEAD OFFICE: Hulic KUDAN BLDG.1-13-5, KUDANKITA CHIYODA-KU, TOKYO 102-0073, JAPAN
NAGOYA ENGINEERING OFFICE:139 SHIMOMAYASHIKIHO-SHIMOMAYASHIKI, KASUGAI, AICHI 486-0906, JAPAN

SAFETY PRECAUTIONS

(Always read these precautions prior to use.)

Before using this product, please read this manual carefully and pay full attention to safety to ensure that the product is used correctly.

The precautions presented in this manual are concerned with this product only. For Programmable Controller system safety precautions, refer to the user's manual of the MELSEC iQ-R Series CPU Module to be used.

If the equipment is used in a manner not specified by the manufacturer, the protection provided by the equipment may be impaired.

In this manual, the safety precautions are ranked as "WARNING" and "CAUTION."



Indicates that incorrect handling may cause hazardous conditions, resulting in death or severe injury.



Indicates that incorrect handling may cause hazardous conditions, resulting in medium or minor injury and/or property damage.

Note that failure to observe the CAUTION level instructions may lead to a serious consequence according to the circumstances. Always follow the precautions of both levels because they are important to personal safety.

Please keep this manual in an easy-to-access location for future reference, and be sure to provide the manual to the end user.

Precautions before using



- When making a switch to the MELSEC iQ-R Series, be sure to consult user's manual supplied with individual module under the MELSEC iQ-R Series to confirm differences in various aspects including performance, function, CPU input/output signals between the two modules.

Installation Precautions



- Use the Conversion Adapter in the environmental conditions that are specified in the general specification. If the Products are used in any environment beyond the bounds of the general specification, electric shock, fire, malfunction, or damage to or degradation of the Products will result.
Do not directly touch any conductive parts of Conversion Adapter. Contact will cause malfunction or failure in the system.
Fasten the Conversion Adapter and the Mounting Bracket securely with retaining screws, and tighten the screws by applying torque within specified limits. Loose screws can lead to the dropping of the Conversion Adapter or Mounting Bracket, possibly causing breakage thereof. Excessive tightness of the screws can lead to breakage of the screws, Conversion Adapter, Mounting Bracket, or MELSEC iQ-R Series Module, possibly causing the dropping, shorting, and malfunction thereof.
Always check for correct match between MELSEC iQ-R Series and the Conversion Adapter. Incorrect match can cause damage to the MELSEC iQ-R Series Module.
When installing the Conversion Adapter, take care not to get your hand snagged on the Mounting Bracket or the like. Injury may result.
When installing or removing the MELSEC iQ-R Series Module complete with a Converter Adapter, be sure to hold it with both hands. Dropping may lead to breakage.

Wiring Precautions



- Before attempting to install the Unit or carry out the necessary wiring, make certain that the external power supply, used in the system, is shut off on all three phases. Failure to do so may result in electric shock or damage to the product.



- Carry out wiring for the Conversion Adapter correctly after checking the specification and terminal arrangement for the module used. Connecting a power supply with a different voltage rating or incorrect wiring may cause a fire or failure.
Tighten the connector screws securely by applying torque within the specified limits. Loose screws will cause short circuit, fire or malfunction. Excessive tightening will damage the screws or the Conversion Adapter which in turn will cause dropping of parts, short circuit or malfunction.
Use care to prevent foreign materials including cuttings and wiring debris from entering the Conversion Adapter or the MELSEC iQ-R Series Module. These will be cause for fire, failure or malfunction.

Startup and Maintenance Precautions



- Do not touch live connectors. There is a danger of electric shock or malfunction.
Shut off the external power supply for the system in all phases before cleaning or retightening the terminal screws. Failure to do so may result in electric shock or cause the MELSEC iQ-R Series Module to fail or malfunction. Loose screws can lead to dropping, shorting, and malfunction. Excessive tightness of the screws can lead to breakage of the screws, Conversion Adapter, Mounting Bracket, or MELSEC iQ-R Series Module, possibly causing the dropping, shorting, and malfunction thereof.



- Do not modify the Conversion Adapter or take it apart. Doing so will cause failure, malfunction, personal injury, or fire.
Do not drop the Conversion Adapter and Mounting Bracket or do not give a strong impact to it. This will cause damage.

Disposal Precautions



- When disposing of the product, treat it as industrial waste.

安全注意事项

(使用前请务必阅读)

使用本产品时, 请仔细阅读本手册, 并充分注意安全, 正确地使用产品。本手册中标注的注意事项仅记载了与本产品相关的内容。关于可编程控制器系统的安全注意事项, 请参阅所使用的MELSEC iQ-R系列CPU模块的用户手册。请勿在所记载内容的范围外使用, 否则会损坏产品的保护功能。在本安全注意事项中, 安全注意事项的等级分为「警告」和「注意」。



表示错误操作可能造成危险后果, 引起死亡或重伤事故。



表示错误操作可能造成危险后果, 引起中度伤害, 轻伤及财产损失。

另外, 根据情况不同, 即使是注意中记载的事项, 也可能引发严重后果。不管哪个记载的都是非常重要的内容, 请务必遵守。请妥善保管本手册, 以便需要时取阅, 并将本手册交给最终用户。

使用前的注意事项

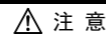

- 替换至 MELSEC iQ-R 系列时, 为确认性能, 功能, CPU 对应的输入输出信号等方面的差异, 请务必参照 MELSEC iQ-R 系列的各模块的手册进行使用。

安装注意事项

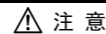

- 应在一般规格环境下使用转换适配器。如果在一般规格范围以外的环境中使用转换适配器, 可能导致触电, 火灾, 误动作, 产品损坏或性能劣化。
请不要直接触摸转换适配器的导电部分。否则可能会造成系统误动作, 故障。
转换适配器及安装配件应通过安装螺钉切实地加以固定, 安装螺钉应在规定的扭矩范围内切实地拧紧。如果螺钉拧得过松, 有可能因掉落而导致转换适配器及安装配件破损。如果螺钉拧得过紧, 有可能造成螺钉, 转换适配器, 安装配件及 MELSEC iQ-R 系列模块破损, 从而导致掉落, 短路或误动作。
请务必确认 MELSEC iQ-R 系列模块和转换适配器的组合是否正确。在错误组合下使用时, 可能会导致 MELSEC iQ-R 系列模块损坏。
安装转换适配器时, 应注意不要使手等身体部分刮到安装配件。否则可能会导致受伤。
在对安装了转换适配器的 MELSEC iQ-R 系列模块进行装卸时, 请务必用双手拿住产品。否则会因落下而导致损坏。

接线注意事项



- 在进行安装, 配线作业等时, 必须将系统使用的外部供应电源全部断开后再进行操作。如果未全部断开, 有可能导致触电或产品损坏。

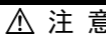

- 请确认所使用模块的规格及端子排列后正确地进行转换适配器的接线。如果输入不符合额定值的电压, 连接不符合额定值的电源或接错线, 可能会导致火灾或故障。
连接器安装螺钉应在规定的扭矩范围内切实地拧紧。如果螺钉拧得过松, 有可能导致短路, 火灾或误动作。如果螺钉拧得过紧, 有可能造成螺钉及转换适配器破损从而导致掉落, 短路或误动作。
请注意不要让切屑或接线头等异物进入转换适配器及 MELSEC-Q 系列模块内。否则可能会导致火灾, 故障, 误动作。

启动和维护注意事项



- 在通电状态下请勿触摸导电部分。否则可能导致触电或误动作。
在清洁模块或重新紧固端子螺钉时, 必须将系统使用的外部供应电源全部断开后再进行操作。如果未全部断开, 有可能导致触电或 MELSEC iQ-R 系列模块故障, 误动作。如果螺钉拧得过松, 有可能导致掉落, 短路或误动作。如果螺钉拧得过紧, 有可能导致螺钉, 转换适配器, 安装配件及 MELSEC iQ-R 系列模块破损, 从而导致掉落, 短路或误动作。

启动和维护注意事项

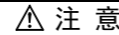

- 请不要拆卸, 改造转换适配器。否则可能会导致故障, 误动作, 受伤或火灾。
请勿使转换适配器及安装配件掉落或受到强烈撞击。否则可能导致破损。

废弃注意事项

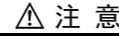

- 废弃时请将本产品作为工业废弃物处理。

EMC AND LOW VOLTAGE DIRECTIVES

Compliance to the EMC Directive, which is one of the EU Directives, has been a legal obligation for the products sold in European countries since 1996 as well as the Low Voltage Directive since 1997. Manufacturers who recognize their products are compliant to the EMC and Low Voltage Directives are required to declare that print a "CE mark" on their products.

Authorized representative in Europe

Authorized representative in Europe is shown below.
Name: Mitsubishi Electric Europe B.V.
Address: Mitsubishi-Electric-Platz 1, 40882 Ratingen, Germany

1. Overview

This manual describes specifications, handling and other information about the Conversion Adapter "ERNT-2CR216X218X" available as Renewal Tools for the Mitsubishi Electric Programmable Controller.

Before attempting to make a switch to MELSEC iQ-R Series in your installation, consult the user's manual supplied with individual module under the latter series to learn about how they differ in various aspects including performance and function.

Once you have opened the packaging, verify that it contains the following products.

Table with 3 columns: Product, Shape, Quantity. Rows include Conversion Adapter (1), Mounting Bracket (1), Mounting Bracket fixing screws (2), and This manual (1).

2. Specifications

2.1 General Specifications

Table with 2 columns: Item, Specifications. Rows include Operating ambient temperature, Storage ambient temperature, Operating ambient humidity, Storage ambient humidity, Vibration resistance, Shock resistance, Operating atmosphere, Operating altitude, Installation location, Overvoltage category, and Pollution degree.

- *1: Do not use or store under pressure higher than the atmospheric pressure of altitude 0m.
*2: The enclosure is suitably designed for those specific environmental conditions, as applicable, and enclosure rate meets IP20 and minimum type 1 of UL 50.
*3: This indicates the section of the power supply to which the equipment is assumed to be connected between the public electrical power distribution network and the machinery within premises. Category II applies to equipment for which electrical power is supplied from fixed facilities.
*4: This index indicates the degree to which conductive material is generated in terms of the environment in which the equipment is used. Pollution level 2 is when only non-conductive pollution occurs. A temporary conductivity caused by condensing must be expected occasionally.

2.2 Hardware Specifications

Table with 2 columns: Item, Specifications. Row: Rated voltage / current, 5-24VDC(+20/-15%), 6mA

3. Product Specifications

For detail specifications which do not appear in the specification comparison charts contained herein, see the user's manual supplied with the MELSEC iQ-R Series Module you use. Also, check that the specifications of the connected devices meet the specifications of the MELSEC iQ-R Series Module.

Table with 7 columns: Conversion Adapter Model, No. of modules, Before replacement SYSMAC C Series Module Model, No. of Input Points, After replacement MELSEC iQ-R Series Module Model, No. of modules, Conversion Adapter Weight (g). Rows for ERNT-2CR216X218X with 1 and 2 modules.

*1 Two sets of MELSEC iQ-R Series Modules and the Conversion Adapter are required (32 points for each set).

*2 This indicates the weight for one Conversion Adapter.

Table with 3 columns: Signal Name, SYSMAC C Series connector, MELSEC iQ-R Series connector. Rows for Module (a) and Module (b).

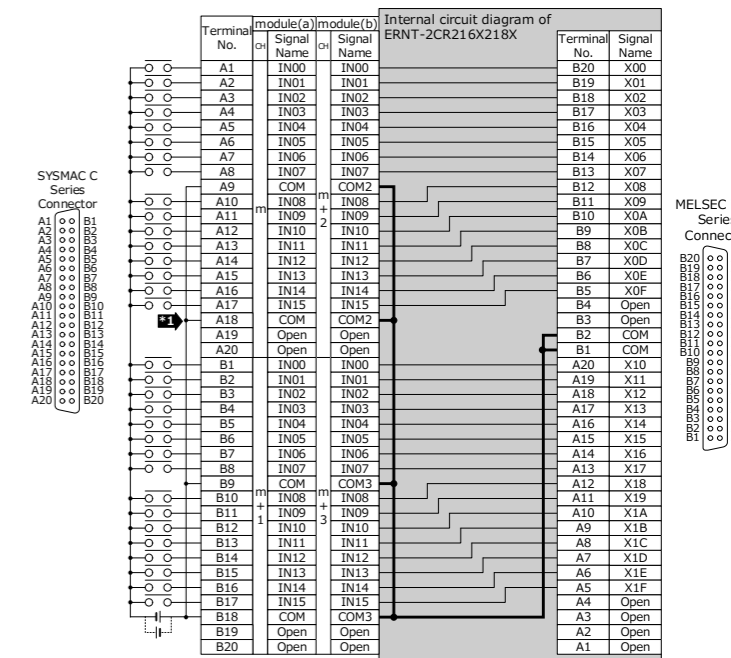

Precautions for wiring

- For the replacement from the CS1W-MD261(input part), CS1W-MD262(input part) or CS1W-MD561(input part), because the switch concerned causes the number of points per common to change from 16 (two circuits) to 32 (one circuit), an alteration to the wiring is required if the commons on the existing modules have been used in separation from each other.

Signal Name	SYSMAC C Series Connector	MELSEC iQ-R Series Connector
module(c)	CS1W-ID231	RX41C4 RX41C6HS

Signal Name	SYSMAC C Series connector	MELSEC iQ-R Series connector	No. of modules
Module (d)	C200H-ID217	RX41C4	2
	C200H-ID219	RX41C6HS	
	C200H-ID111	RX71C4	
Module (e)	CS1W-ID261	RX41C4 RX41C6HS	2

Signal Name	SYSMAC C Series connector	MELSEC iQ-R Series connector	No. of modules
module(f)	C500-ID219	RX41C4 RX41C6HS	2
	C500-ID114	RX71C4	

<Specification Comparison Chart>

Model	SYSMAC C Series		MELSEC iQ-R Series	
	CS1W-MD561 (input part) (Positive/Negative common Shared Type)	RX61C6HS (Positive/Negative common Shared Type)	RX71C4 (Positive/Negative common Shared Type)	RX41C4 (Positive/Negative common Shared Type)
Specifications				
Number of input points	32 points	32 points	32 points	32 points
Rated input voltage	5VDC±10%	5VDC (4.25 to 6VDC)	5VDC(4.25 to 6VDC)	5VDC(4.25 to 6VDC)
Rated input current	Approx 3.5mA (5VDC)	6.0mA TYP.(5VDC)	1.7mA TYP. (5VDC) 4.8mA TYP. (12VDC)	1.7mA TYP. (5VDC) 4.8mA TYP. (12VDC)
ON voltage/ON current	3.0V or higher	3.5V or higher/ 3mA or higher	3.5V or higher/ 1mA or higher	3.5V or higher/ 1mA or higher
OFF voltage/OFF current	1.0V or lower	1V or lower/ 1mA or lower	1V or lower/ 0.1mA or lower	1V or lower/ 0.1mA or lower
Input resistance	1.1kΩ	600Ω	2.3kΩ	2.3kΩ
Response time	OFF→ON	8.0ms or less	0.1/0.2/0.4/0.6/1/5/10/20/70ms or less	0.2/0.3/0.5/0.6/1/5/10/20/70ms or less
	ON→OFF	8.0ms or less	0.1/0.2/0.4/0.6/1/5/10/20/70ms or less	0.21/0.3/0.5/0.6/1/5/10/20/70ms or less
Internal current consumption	270mA or lower/module	150mA (TYP. all points ON)	140mA (TYP. all points ON)	140mA (TYP. all points ON)
Wiring method for common	16 points/common (2 circuits)	32 points/common	32 points/common	32 points/common
External connection system	40-pin connector	40-pin connector	40-pin connector	40-pin connector

Make sure the [] section of the above table meets the specification of the machines and equipment connected to the MELSEC iQ-R Series module.

Model	SYSMAC C Series			MELSEC iQ-R Series
	CQM1-ID112 (Positive/Negative common Shared Type)	C200H-ID111 (Positive/Negative common Shared Type)	C500-ID114 (Positive/Negative common Shared Type)	RX71C4 (Positive/Negative common Shared Type)
Specifications				
Number of input points *1	32 points	64 points	64 points	32 points
Rated input voltage	12VDC (+10%/-15%)	12VDC (+10%/-15%)	12VDC (+10%/-15%)	5VDC (4.25 to 6VDC) 12VDC (10.2 to 14.4VDC)
Rated input current	4mA TYP. (12VDC)	4.1mA TYP. (12VDC)	7mA TYP. (12VDC)	1.7mA TYP. (5VDC) 4.8mA TYP. (12VDC)
ON voltage/ON current	8.0V or higher	8.0V or higher	8.0V or higher	3.5V or higher/ 1mA or higher
OFF voltage/OFF current	3.0V or lower	3.0V or lower	3.0V or lower	1V or lower/ 0.1mA or lower
Input resistance	2.2kΩ	2.7kΩ	1.5kΩ	2.3kΩ
Response time	OFF→ON	8ms or less	1.0ms or less	1.5ms or less
	ON→OFF	8ms or less	1.0ms or less	1.5ms or less
Internal current consumption	170mA or lower	120mA or lower	340mA or lower	140mA (TYP. all points ON)
Wiring method for Common	32 points/common	32 points/common (2 circuits)	8 points/common (8 circuits)	32 points/common
External connection system	40-pin connector	40-pin connector	40-pin connector x2	40-pin connector

Make sure the [] section of the above table meets the specification of the machines and equipment connected to the MELSEC iQ-R Series module.

*1: To replace the C200H-ID111 or C500-ID114, two sets of MELSEC iQ-R Series Modules and the Conversion Adapter are required.

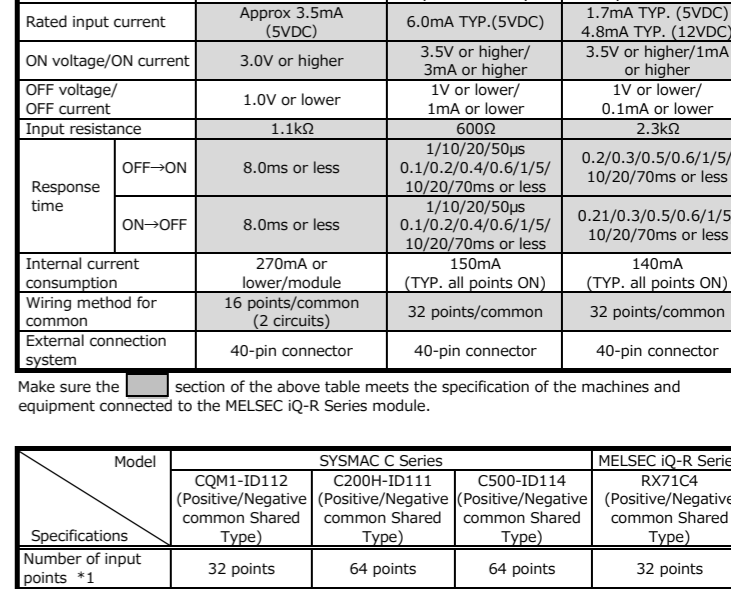
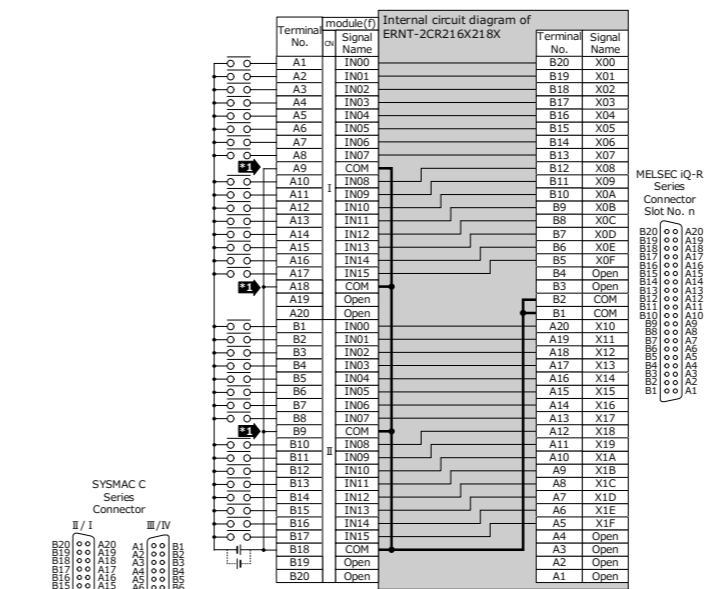
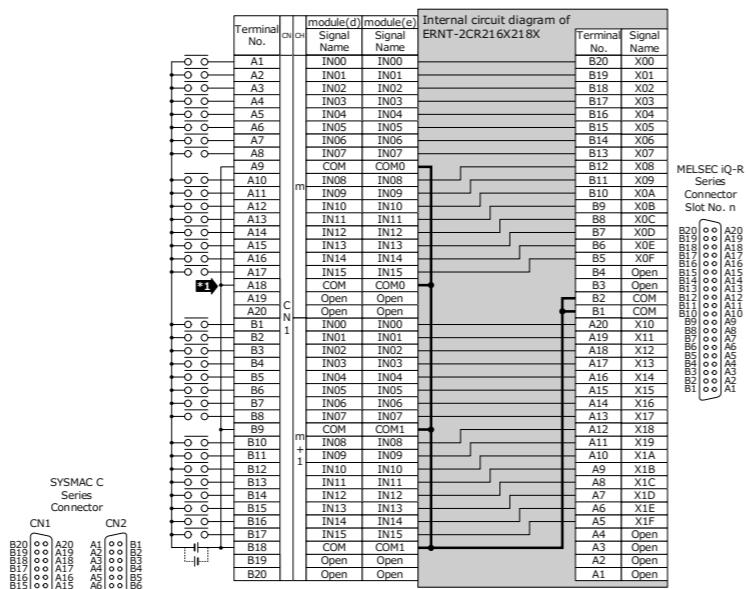
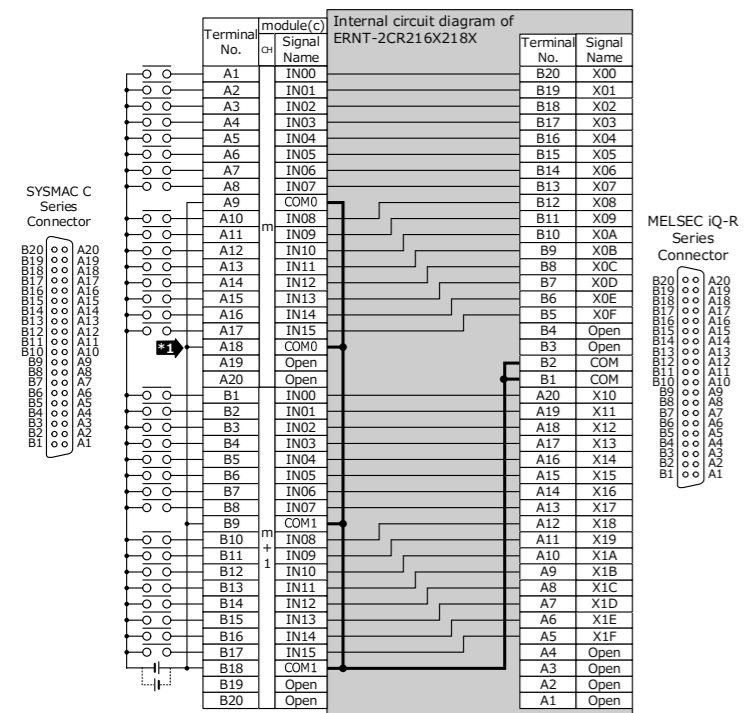

Precautions for wiring

*1 Because the switch concerned causes the number of points per common to change from 16 (two circuits) to 32 (one circuit), an alteration to the wiring is required if the commons on the existing modules have been used in separation from each other.

Precautions for wiring

*1 For the replacement from the CS1W-ID261, because the switch concerned causes the number of points per common to change from 16 (four circuits) to 32 (two modules), an alteration to the wiring is required if the commons on the existing modules have been used in separation from each other.

Precautions for wiring

*1 Because the switch concerned causes the number of points per common to change from 8 (eight circuits) to 32 (two modules), an alteration to the wiring is required if the commons on the existing modules have been used in separation from each other.

<Specification Comparison Chart>

Model	SYSMAC C Series				MELSEC iQ-R Series	
	C200H-ID216 (Positive/Negative common Shared Type)	C200H-ID218 (Positive/Negative common Shared Type)	C200H-ID217 (Positive/Negative common Shared Type)	C200H-ID219 (Positive/Negative common Shared Type)	RX41C4 (Positive/Negative common Shared Type)	RX41C6HS (Positive/Negative common Shared Type)
Specifications						
Number of input points *1	32 points	32 points	64 points	64 points	32 points	32 points
Rated input voltage	24VDC (+10%/-15%)	24VDC (+10%/-15%)	24VDC (+10%/-15%)	24VDC (+10%/-15%)	24VDC (20.4 to 28.8VDC)	24VDC (20.4 to 28.8VDC)
Rated input current	4.1mA TYP. (24VDC)	6mA TYP. (24VDC)	4.1mA TYP. (24VDC)	6mA TYP. (24VDC)	4.0mA TYP. (at 24VDC)	6.0mA TYP. (at 24VDC)
ON voltage/ON current	14.4V or higher	15.4V or higher / 3.5mA or higher	14.4V or higher	15.4V or higher / 3.5mA or higher	19V or higher / 3mA or higher	19V or higher / 4mA or higher
OFF voltage/OFF current	5.0V or lower	5.0V or lower / 1mA or lower	5.0V or lower	5.0V or lower / 1mA or lower	6V or lower / 1.0mA or lower	6V or lower / 1.7mA or lower
Input resistance	5.6kΩ	3.9kΩ	5.6kΩ	3.9kΩ	5.3kΩ	4kΩ
Response time	OFF→ON	1.0ms or less	1.0ms or less	1.0ms or less	0.1/0.2/0.4/0.6/1/5/10/20/70ms or less	1/10/20/50μs 0.1/0.2/0.4/0.6/1/5/10/20/70ms or less
	ON→OFF	1.0ms or less	1.0ms or less	1.0ms or less	1.0ms or less	0.2/0.3/0.5/0.7/1/5/10/20/70ms or less
Internal current consumption	100mA or lower	100mA or lower	120mA or lower	120mA or lower	150mA (TYP. All points ON)	150mA (TYP. All points ON)
Wiring method for common	32 points/common	32 points/common	32 points/common (2 circuits)	32 points/common (2 circuits)	32 points/common	32 points/common
External connection system	40-pin connector	40-pin connector	40-pin connector x2	40-pin connector x2	40-pin connector	40-pin connector

Make sure the [] section of the above table meets the specification of the machines and equipment connected to the MELSEC iQ-R Series module.
*1: To replace the C200H-ID217 or C200H-ID219, two sets of MELSEC iQ-R Series Modules and the Conversion Adapter are required.

<Specification Comparison Chart>

Model	SYSMAC C Series				MELSEC iQ-R Series	
	CS1W-ID231 (Positive/Negative common Shared Type)	CS1W-ID261 (Positive/Negative common Shared Type)	CS1W-MD261 (input part) (Positive/Negative common Shared Type)	CS1W-MD262 (input part) (Positive/Negative common Shared Type)	RX41C4 (Positive/Negative common Shared Type)	RX41C6HS (Positive/Negative common Shared Type)
Specifications						
Number of input points *1	32 points	64 points	32 points	32 points	32 points	32 points
Rated input voltage	20.4 to 26.4VDC	20.4 to 26.4VDC	20.4 to 26.4VDC	20.4 to 26.4VDC	24VDC (20.4 to 28.8VDC)	24VDC (20.4 to 28.8VDC)
Rated input current	6mA TYP. (24VDC)	6mA TYP. (24VDC)	6mA TYP. (24VDC)	6mA TYP. (24VDC)	4.0mA TYP. (at 24VDC)	6.0mA TYP. (at 24VDC)
ON voltage/ON current	15.4V or higher / 3mA or higher	15.4V or higher / 3mA or higher	15.4V or higher / 3mA or higher	15.4V or higher / 3mA or higher	19V or higher / 3mA or higher	19V or higher / 4mA or higher
OFF voltage/OFF current	5V or lower / 1mA or lower	5V or lower / 1mA or lower	5V or lower / 1mA or lower	5V or lower / 1mA or lower	6V or lower / 1.0mA or lower	6V or lower / 1.7mA or lower
Input resistance	3.9kΩ	3.9kΩ	3.9kΩ	3.9kΩ	5.3kΩ	4kΩ
Response time	OFF→ON	8.0ms or less	8.0ms or less	8.0ms or less	0.1/0.2/0.4/0.6/1/5/10/20/70ms or less	1/10/20/50μs 0.1/0.2/0.4/0.6/1/5/10/20/70ms or less
	ON→OFF	8.0ms or less	8.0ms or less	8.0ms or less	8.0ms or less	0.2/0.3/0.5/0.7/1/5/10/20/70ms or less
Internal current consumption	150mA or lower	150mA or lower	270mA or lower/module	270mA or lower/module	150mA (TYP. all points ON)	150mA (TYP. all points ON)
Wiring method for common	16 points/common (2 circuits)	16 points/common (4 circuits)	16 points/common (2 circuits)	16 points/common (2 circuits)	32 points/common	32 points/common
External connection system	40-pin connector	40-pin connector x2	40-pin connector	40-pin connector	40-pin connector	40-pin connector

Make sure the [] section of the above table meets the specification of the machines and equipment connected to the MELSEC iQ-R Series module.
*1: To replace the CS1W-ID261, two sets of MELSEC iQ-R Series Modules and the Conversion Adapter are required.

<Specification Comparison Chart>

Specifications	SYSMAC C Series		MELSEC iQ-R Series	
	CQM1-ID213 (Positive/Negative common Shared Type)	CQM1-ID214 (Positive/Negative common Shared Type)	RX41C4 (Positive/Negative common Shared Type)	RX41C6HS (Positive/Negative common Shared Type)
Number of input points	32 points	32 points	32 points	32 points
Rated input voltage	24VDC (+10%/-15%)	24VDC (+10%/-15%)	24VDC (20.4V to 28.8VDC)	24VDC (20.4V to 28.8VDC)
Rated input current	5mA TYP. (24VDC)	6mA TYP. (24VDC)	4.0mA TYP. (24VDC)	6.0mA TYP. (24VDC)
ON voltage/ ON current	14.4V or higher	15.4V or higher/ 3.5mA or higher	19V or higher/ 3mA or higher	19V or higher/ 4mA or higher
OFF voltage/ OFF current	5.0V or lower	5.0V or lower/ 1mA or lower	6V or lower/ 1.0mA or lower	6V or lower/ 1.7mA or lower
Input resistance	4.7kΩ	3.9kΩ	5.3kΩ	4kΩ
Response time	OFF→ON	8.0ms or less	0.1/0.2/0.4/0.6/1/5/10/20/70ms or less	1/10/20/50μs 0.1/0.2/0.4/0.6/1/5/10/20/70ms or less
	ON→OFF	8.0ms or less	0.2/0.3/0.5/0.7/1/5/10/20/70ms or less	1/10/20/50μs 0.1/0.2/0.4/0.6/1/5/10/20/70ms or less
Internal current consumption	170mA or lower	170mA or lower	150mA (TYP. all points ON)	150mA (TYP. all points ON)
Wiring method for common	32 points/ common	32 points/ common	32 points/ common	32 points/ common
External connection system	40-pin connector	40-pin connector	40-pin connector	40-pin connector

Make sure the [] section of the above table meets the specification of the machines and equipment connected to the MELSEC iQ-R Series module.

Specifications	Model	SYSMAC C Series		MELSEC iQ-R Series	
		C500-ID219 (Positive/Negative common Shared Type)	RX41C4 (Positive/Negative common Shared Type)	RX41C6HS (Positive/Negative common Shared Type)	RX41C6HS (Positive/Negative common Shared Type)
Number of input points *1		64 points	32 points	32 points	32 points
Rated input voltage		24VDC (+10%/-15%)	24VDC (20.4V to 28.8VDC)	24VDC (20.4V to 28.8VDC)	24VDC (20.4V to 28.8VDC)
Rated input current		7mA TYP. (24VDC)	4.0mA TYP. (24VDC)	6.0mA TYP. (24VDC)	6.0mA TYP. (24VDC)
ON voltage/ ON current		16.0V or higher	19V or higher/ 3mA or higher	19V or higher/ 3mA or higher	19V or higher/ 4mA or higher
OFF voltage/ OFF current		5.0V or lower	6V or lower/ 1.0mA or lower	6V or lower/ 1.0mA or lower	6V or lower/ 1.7mA or lower
Input resistance		3.3kΩ	5.3kΩ	4kΩ	4kΩ
Response time	OFF→ON	1.5ms or less	0.1/0.2/0.4/0.6/1/5/10/20/70ms or less	1/10/20/50μs 0.1/0.2/0.4/0.6/1/5/10/20/70ms or less	1/10/20/50μs 0.1/0.2/0.4/0.6/1/5/10/20/70ms or less
	ON→OFF	1.5ms or less	0.2/0.3/0.5/0.7/1/5/10/20/70ms or less	1/10/20/50μs 0.1/0.2/0.4/0.6/1/5/10/20/70ms or less	1/10/20/50μs 0.1/0.2/0.4/0.6/1/5/10/20/70ms or less
Internal current consumption		340mA or less	150mA (TYP. all points ON)	150mA (TYP. all points ON)	150mA (TYP. all points ON)
Wiring method for common		8 points/common (8 circuits)	32 points/common	32 points/common	32 points/common
External connection system		40-pin connector x2	40-pin connector	40-pin connector	40-pin connector

Make sure the [] section of the above table meets the specification of the machines and equipment connected to the MELSEC iQ-R Series module.

*1: To replace the C500-ID219, two sets of MELSEC iQ-R Series Modules and the Conversion Adapter are required.

4. Mounting and Installation

4.1 Handling Precautions

- Before attempting to install the Unit or carry out the necessary wiring, make certain that the external power supply, used in the system, is shut off on all three phases. Failure to do so may result in electric shock or damage to the product.
- Do not touch live connectors. There is a danger of electric shock or malfunction.
- Do not modify the Conversion Adapter or take it apart. Doing so will cause failure, malfunction, personal injury, or fire.
- Do not touch the energized part of the Conversion Adapter directly. Contact will cause malfunction or failure in the system.
- Fasten the Conversion Adapter and the Mounting Bracket securely with retaining screws, and tighten the screws by applying torque within specified limits. Loose screws can lead to the dropping of the Conversion Adapter, or Mounting Bracket, possibly causing breakage thereof. Excessive tightness of the screws can lead to breakage of the screws, Converter Adapter, Mounting Bracket, or MELSEC iQ-R Series Module, possibly causing the dropping, shorting, and malfunction thereof.
- Use care to prevent foreign materials including cuttings and wiring debris from entering the Conversion Adapter or the MELSEC iQ-R Series Module. These will be cause for fire, failure or malfunction.
- Do not drop the Conversion Adapter and Mounting Bracket or do not give a strong impact to it. This will cause damage.
- Conversion Adapter is intended for indoor use only.

4.2 Use Precautions

Item	Use Precautions														
	SYSMAC C Series (C200H,CS,CQM1 Series)	SYSMAC C Series (C500 Series)													
Depth dimension	The depth dimension increases as follows. Verification prior to installation is required.														
	<table border="1"> <thead> <tr> <th colspan="4">CQM1 Series</th> <th rowspan="2">Unit:mm</th> </tr> <tr> <th>C200H Series</th> <th>CS Series</th> <th>Installation with the DIN rail</th> <th>Installation with the Control panel</th> </tr> </thead> <tbody> <tr> <td> </td> <td> </td> <td> </td> <td> </td> <td rowspan="2"> </td> </tr> </tbody> </table>		CQM1 Series				Unit:mm	C200H Series	CS Series	Installation with the DIN rail	Installation with the Control panel				
CQM1 Series				Unit:mm											
C200H Series	CS Series	Installation with the DIN rail	Installation with the Control panel												
<p>* The depth dimension is the dimension from each surface. SYSMAC C Series (C200H and CS Series): Base unit + Input/output module + Connector SYSMAC C Series (CQM1 Series): Input/output module + connector MELSEC iQ-R Series + Renewal Tool: Base unit + Input/output module + Conversion Adapter + connector</p>															
Connector direction	Since the Conversion Adapter and connector directions of the following modules are upside down, check that the cable can be connected to the Conversion Adapter. If the existing FCN connector cable comes out from the bottom as shown in the right figure, the cable may not be long enough for rotating 180 degrees.														
	<table border="1"> <thead> <tr> <th colspan="2">Target models</th> </tr> </thead> <tbody> <tr> <td>32-point input module</td> <td>64-point input module</td> </tr> </tbody> </table>	Target models		32-point input module	64-point input module	<table border="1"> <tbody> <tr> <td> CS1W-ID231 </td> <td> C200H-ID217 (only the connector on the left side) C200H-ID219 (only the connector on the left side) CS1W-ID261 (only the connector on the left side) </td> </tr> <tr> <td colspan="2">No constraint</td> </tr> </tbody> </table>	CS1W-ID231 	C200H-ID217 (only the connector on the left side) C200H-ID219 (only the connector on the left side) CS1W-ID261 (only the connector on the left side) 	No constraint						
Target models															
32-point input module	64-point input module														
CS1W-ID231 	C200H-ID217 (only the connector on the left side) C200H-ID219 (only the connector on the left side) CS1W-ID261 (only the connector on the left side) 														
No constraint															

4.3 Installation Environment

Refer to "Safety Guidelines" for MELSEC iQ-R Series Modules.

4.4 Wiring module power source

External connection to 24VDC power supply circuit of Conversion Adapter must be powered from approved source that meets of SELV/PELV, Class 2, and limited energy according to UL 61010-2-201.

5. Part Names and Installation Method

In the case one module (32 points)

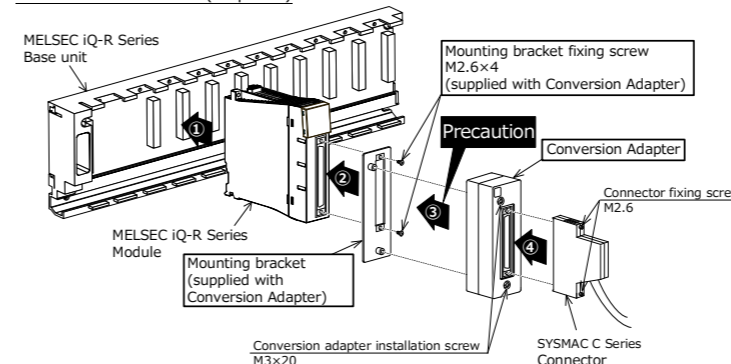

In the case two modules (64 points)

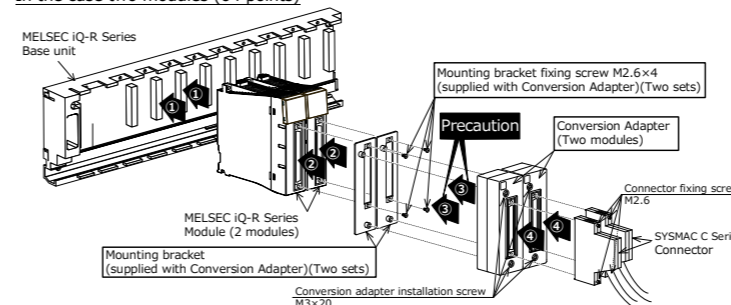

5.1 Installation Method

Installation with the Control panel	Installation with the DIN rail
Install the MELSEC iQ-R Series Base Unit on the control panel. For how to install the Base Unit on the control panel, refer to the MELSEC iQ-R Module Configuration Manual.	Install the DIN rail mounting adapter manufactured by Mitsubishi Electric to the MELSEC iQ-R Series Base Unit. For how to install the Base Unit on the DIN rail, refer to the MELSEC iQ-R Module Configuration Manual.

- Mount the MELSEC iQ-R Series module to the MELSEC iQ-R Series base unit.
 - Secure the Mounting Bracket to the MELSEC iQ-R Series Module using the Mounting Bracket fixing screws [M2.6 x 4 (Conversion Adapter accessory); two upper/lower locations].
 - Mount the Conversion Adapter onto the Mounting Bracket, and secure the Conversion Adapter using the Conversion Adapter installation screws (M3 x 20; 2 locations).
- Precaution**
Before tightening the installation screws, check that the Conversion Adapter has been securely installed on the MELSEC iQ-R Series Module. Tightening the screws in floating-off state or tilting state will damage the Conversion Adapter installation screws and the Mounting Bracket.
- Secure the connector of the SYSMAC C Series to the Conversion Adapter with the connector installation screws (M2.6; two upper/lower locations).

5.2 Tightening Torque

Tighten the installation screws to the specified torque below. An inappropriate tightening torque could cause the product to fall or result in a short circuit, product failure or malfunction.

Screw Location	Tightening Torque Range
Mounting Bracket fixing screw (M2.6x4)	0.20 to 0.29N·m
Conversion Adapter installation screw (M3x20)	0.43 to 0.57N·m
Connector installation screw (M2.6)	0.20 to 0.29N·m

6. External Dimensions

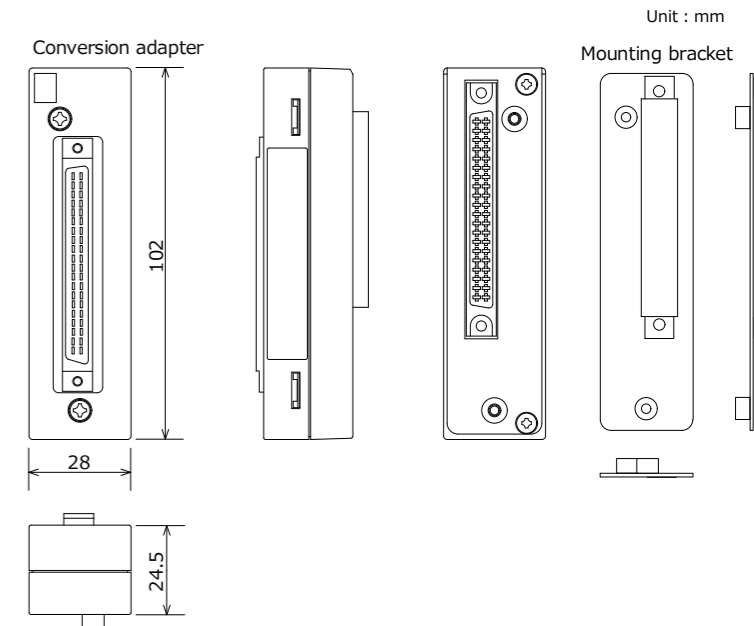

Duplication Prohibited
This manual may not be reproduced in any form, in part or in whole, without written permission from Mitsubishi Electric Engineering Company Limited.
©2018 MITSUBISHI ELECTRIC ENGINEERING COMPANY LIMITED ALL RIGHTS RESERVED

MELSEC and MELSEC iQ-R is a registered trademark of Mitsubishi Electric Corporation in Japan.
ERNT is a registered trademark of Mitsubishi Electric Engineering Company Limited in Japan.
All company and product names herein are either trademarks or registered trademarks of their respective owners.

Product Warranty Details

Please confirm the following product warranty details prior to product use.

Gratis Warranty Terms and Gratis Warranty Range

If any fault or defect (hereinafter referred to as "Failure") attributable to Mitsubishi Electric Engineering Company Limited (hereinafter referred to as "MEE") should occur within the gratis warranty period, MEE shall repair the product free of charge via the distributor from whom you made your purchase.

■ Gratis Warranty Period

The gratis warranty period of this product shall be one (1) year from the date of purchase or delivery to the designated place.
Note that after manufacture and shipment from MEE, the maximum distribution period shall be six (6) months, and the gratis warranty period after manufacturing shall be limited to eighteen (18) months.
In addition, the gratis warranty period for repaired products shall not exceed the gratis warranty period established prior to repair.

■ Gratis Warranty Range

The gratis warranty range shall be limited to normal use based on the usage conditions, methods and environment, etc., defined by the terms and precautions, etc., given in the instruction manual, user's manual and caution labels on the product.

Warranty Period after Discontinuation of Production

- MEE shall offer product repair services (fee applied) for seven (7) years after production of the product has been discontinued. Discontinuation of production shall be reported via distributors.
- Product supply (including spare parts) is not possible after production has been discontinued.

Exclusion of Opportunity Loss and Secondary Loss from Warranty Liability

Regardless of the gratis warranty period, MEE shall not be liable for compensation for damages arising from causes not attributable to MEE, opportunity losses or lost profits incurred by the user due to Failures of MEE products, damages or secondary damages arising from special circumstances, whether foreseen or unforeseen by MEE, compensation for accidents, compensation for damages to products other than MEE products, or compensation for other work carried out by the user.

Changes in Product Specifications

The specifications given in the catalogs, manuals and technical documents are subject to change without notice.

This document is a new publication, effective July 2020. Specifications are subject to change without notice.