

# Mitsubishi Electric Programmable Controller Upgrade Tool

## Conversion Adapter

Model  
**ERNT-ASQTY80**



## User's Manual

50CM-D180338-A(1804)

### MITSUBISHI ELECTRIC ENGINEERING COMPANY LIMITED

HEAD OFFICE: Huliic KUDAN BLDG.1-13-5, KUDANKITA CHIYODA-KU, TOKYO 102-0073, JAPAN  
NAGOYA ENGINEERING OFFICE:139 SHIMOYASHIKI-KO-SHIMOYASHIKI, KASUGAI, AICHI 486-0906, JAPAN

### SAFETY PRECAUTIONS

(Always read these precautions prior to use.)

Before attempting to use the Conversion Adapter (or the Products), read all instructions contained in this manual carefully to ensure safe and correct operation.

The safety instructions appearing in this manual are limited to those that apply to the Products. For safety instructions to be heeded in regard to your programmable controller system as a whole, refer to the following manuals.

- MELSEC-Q series: QCPU User's Manual (SH-080483ENG)
- MELSEC iQ-R series: Safety Guidelines (IB-0800525E)

In this manual, the safety precautions are ranked as "WARNING" and "CAUTION."

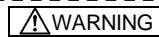

Indicates an immediately hazardous situation which, if not properly dealt with, will result in death or serious injury.



Indicates a hazardous situation which, if not properly dealt with, will result in moderate or mild injury, or property damage alone.

Even a safety instruction marked with "CAUTION" could have serious consequences under certain conditions. All the safety instructions, regardless of their classification of criticality, carry important points to be noted. Observe them without fail.

Save this manual for reference when needed while at the same time ensuring that it is always passed on to the ultimate user.

#### [Precautions: Prior to use]

### CAUTION

- When making a switch from the MELSEC-AnS Series to the MELSEC-Q Series or MELSEC iQ-R Series, be sure to consult user's manual supplied with individual module under the Programmable Controller Module to confirm differences in various aspects including performance and function between the two series.

#### [Installation Precautions]

### CAUTION

- Use the Conversion Adapter in the environmental conditions that are specified in the general specification in the following manuals. If the Products are used in any environment beyond the bounds of the general specification, electric shock, fire, malfunction, or damage to or degradation of the Products will result..
  - Q Series: QCPU User's Manual (SH-080483ENG)
  - MELSEC iQ-R Series: Safety Guidelines (IB-0800525E)
- Do not touch live uninsulated part directly. Contact will cause malfunction or failure in the system.
- Fasten the Conversion Adapter and the Fittings securely with retaining screws, and tighten the screws by applying torque within specified limits. Loose screws can lead to the dropping of the converter adapter or fittings, possibly causing breakage thereof. Excessive tightness of the screws can lead to breakage of the screws, converter adapter, fittings, or Programmable Controller module, possibly causing the dropping, shorting, and malfunction thereof.
- Always check for correct match between MELSEC-Q Series or MELSEC iQ-R Series and the Conversion Adapter. Incorrect match can cause damage to the Programmable Controller module.
- When installing the converter adapter, take care not to get your hand snagged on the fittings or the like. Injury may result.
- When installing or removing the MELSEC-Q Series or MELSEC iQ-R Series Module complete with a Converter Adapter, be sure to hold it with both hands. Dropping may lead to breakage.

#### [Wiring Precautions]

### WARNING

- Before attempting to install the Unit or carry out the necessary wiring, make certain that the external power supply, used in the system, is shut off on all three phases. Failure to do so may result in electric shock or damage to the product.
- When energizing the Products or putting them into operation after the completion of installation or wiring work, always have a cover placed over the terminal block for the MELSEC-AnS Series components. Without the cover placed in position, electric shock can result.

### CAUTION

- Carry out wiring for the Conversion Adapter correctly after checking the specification and terminal arrangement for the module used. Connecting a power supply with a different voltage rating or incorrect wiring may cause a fire or failure.
- Tighten the MELSEC-AnS Series terminal attaching screws and terminal screw securely by applying torque within the specified limits. Loose screws will cause short circuit, fire or malfunction. Excessive tightening will damage the screws or the Conversion Adapter which in turn will cause dropping of parts, short circuit or malfunction.
- Use care to prevent foreign materials including cuttings and wiring debris from entering the Conversion Adapter or the Programmable Controller module. These will be cause for fire, failure or malfunction.

#### [Startup and Maintenance Precautions]

### WARNING

- Do not touch live terminals. There is a danger of electric shock or malfunction.
- Shut off the external power supply for the system in all phases before cleaning or retightening the terminal screws. Failure to do so may result in electric shock or cause the MELSEC-Q Series or MELSEC iQ-R Series module to fail or malfunction. Loose screws can lead to dropping, shorting, and malfunction. Excessive tightness of the screws can lead to breakage of the screws, converter adapter, fittings, or MELSEC-Q Series or MELSEC iQ-R Series Module, possibly causing the dropping, shorting, and malfunction thereof.

### CAUTION

- Do not modify the Conversion Adapter or take it apart. Doing so will cause failure, malfunction, personal injury, or fire.
- The Conversion Adapter comes in a resin case. Do not drop the Adapter or give a strong impact to it. This will cause damage to the Adapter.

#### [Disposal Precautions]

### CAUTION

- When you dispose of the Products, handle them as industrial waste.

#### EMC AND LOW VOLTAGE DIRECTIVES

Compliance to the EMC Directive, which is one of the EU Directives, has been a legal obligation for the products sold in European countries since 1996 as well as the Low Voltage Directive since 1997.

Manufacturers who recognize their products are compliant to the EMC and Low Voltage Directives are required to declare that print a "CE mark" on their products.

#### Authorized representative in Europe

Authorized representative in Europe is shown below.

Name: Mitsubishi Electric Europe B.V.

Address: Mitsubishi-Electric-Platz 1, 40882 Ratingen, Germany

## 1. Overview

This manual describes the Mitsubishi Electric Programmable Controller Upgrade Tool conversion adapter (ERNT-ASQTY80). The conversion adapter is a product that converts the differences in MELSEC-AnS series (hereinafter called AnS Series) and MELSEC-Q series (hereinafter called Q Series) or MELSEC iQ-R series (hereinafter called iQ-R Series) pin assignments.

When replacing the AnS Series with the Q Series or iQ-R Series, be sure to refer to the Programmable Controller Module manuals to check the differences in performance, functionality, CPU input/output signals, buffer memory addresses and the like. Once you have opened the packaging, verify that it contains the following products.

Product	Shape	Quantity
Conversion adapter		1
Mounting bracket		1
Mounting bracket fixing screw (M3.5 x 6)		2
Terminal block cover		1
This manual	—	1

## 2. General Specifications

Item	Specifications					
Operating ambient temperature	0 to 55°C (Maximum surrounding air temperature 55°C)					
Storage ambient temperature	-25 to 75°C					
Operating ambient humidity	5 to 95%RH, non-condensing					
Storage ambient humidity	5 to 95%RH, non-condensing					
Vibration resistance	Compliant with JIS B 3502 and IEC 61131-2	Under intermittent vibration	Frequency	Constant acceleration	Half amplitude	Sweep count
			5 to 8.4Hz	—	3.5mm	
		Under continuous vibration	8.4 to 150Hz	9.8m/s <sup>2</sup>	—	10 times each in X, Y, Z directions
			5 to 8.4Hz	—	1.75mm	
Shock resistance	Compliant with JIS B 3502 and IEC 61131-2 (147 m/s <sup>2</sup> , 3 times each in 3 directions X, Y, Z)					
	Compliant with JIS B 3502 and IEC 61131-2 (147 m/s <sup>2</sup> , 3 times each in 3 directions X, Y, Z)					
Operating atmosphere	No corrosive gases					
Operating altitude *1	0 to 2000m					
Installation location	Inside a control panel					
Overvoltage category *2	II or less					
Pollution degree *3	2					

\*1 : Do not use or store under pressure higher than the atmospheric pressure of altitude 0m.

\*2 : This indicates the section of the power supply to which the equipment is assumed to be connected between the public electrical power distribution network and the machinery within premises. Category II applies to equipment for which electrical power is supplied from fixed facilities.

\*3 : This index indicates the degree to which conductive material is generated in terms of the environment in which the equipment is used. Pollution level 2 is when only non-conductive pollution occurs. A temporary conductivity caused by condensing must be expected occasionally.

## 3. Conversion Adapter Product Specifications

Conversion Adapter Model	AnS Series Module Model	Number of output points	Module Model		Conversion Adapter Weight (g)
			Q Series	iQ-R Series	
ERNT-ASQTY80	A1SY80	16	QY80	RY40PT5P	75

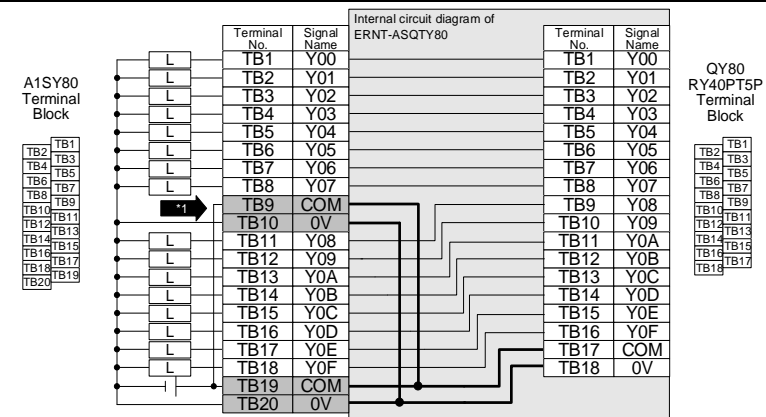

#### <Specification Comparison Chart>

Model	AnS Series	Q Series	iQ-R Series
	A1SY80 (Source Type)	QY80 (Source Type)	RY40PT5P (Source Type)
Specifications			
Number of output points	16 points	16 points	16 points
Isolation method	Photocoupler isolation	Photocoupler isolation	—
Rated load voltage	12/24VDC	12-24VDC (+20/-15%)	12/24VDC (allowable voltage range: 10.2 to 28.8VDC)
Maximum load current	0.8A/point 3.2A/common	0.5A/point 4A/common	0.5A/point, Pilot Duty 5A/common
Maximum inrush current	8A 10ms or less	4A 10ms or less	Current is to be limited by the overload protection function
OFF leakage current	0.1mA or less	0.1mA or less	0.1mA or less
Maximum voltage drop at power-ON	1.5VDC(MAX.) 0.8A	0.2VDC(TYP.) 0.5A 0.3VDC(MAX.) 0.5A	0.2VDC(TYP.) 0.5A 0.3VDC(MAX.) 0.5A
Response time	OFF to ON	2ms or less	1ms or less
	ON to OFF	2ms or less (resistance load)	1ms or less (rated load and resistance load)
Surge killer	Zener diode	Zener diode	Zener diode
Fuse	5A (one/common) non-replaceable	6.7A (one/common) non-replaceable	None
Internal current consumption	120mA (TYP. All points ON)	80mA (TYP. All points ON)	130mA (TYP. All points ON)
External power supply	Voltage	12/24VDC (10.2 to 30VDC)	12-24VDC (+20/-15%, ripple rate within 5%)
	Current	20mA (TYP. 24VDC per common)	20mA (24VDC)
Wiring method for common	8 points/common	16 points/common	16 points/common

#### Note:

- Because the switch concerned causes the number of points per common to change from 8 (two circuits) to 16, an alteration to the wiring is required if the terminal numbers TB9 and TB19, and TB10 and TB20, on the AnS-side terminal block have been used in separation from each other.
- For detailed and general specifications not described in the module specification comparison chart, refer to the user's manual of the module used. Those parts of the specification that differ between the AnS Series and the Q Series or iQ-R Series are where a switch from the first series to the second is subjected to specification-related restrictions. Check the specification of the devices to be connected for more details.

## 4. Mounting and Installation

### 4.1 Handling Precautions

- Before attempting to install the Unit or carry out the necessary wiring, make certain that the external power supply, used in the system, is shut off on all three phases. Failure to do so may result in electric shock or damage to the product.
- Do not touch the terminals during energization. Doing so could result in electric shock or malfunction.
- Do not disassemble or modify the conversion adapter. Doing so could result in failure, malfunction, injury or fire.
- Do not come in direct contact with the conductive area of the conversion adapter. Doing so could result in system malfunction or failure.
- Fasten the Conversion Adapter and the Fittings securely with retaining screws, and tighten the screws by applying torque within specified limits. Loose screws can lead to the dropping of the converter adapter, or fittings, possibly causing breakage thereof. Excessive tightness of the screws can lead to breakage of the screws, converter adapter, fittings, or the Programmable Controller Module, possibly causing the dropping, shorting, and malfunction thereof.
- Take care to prevent foreign materials including cutting chips and wire scraps from entering the Conversion Adapter or the Programmable Controller Module, possibly causing fire, failure or malfunction thereof.
- Do not drop the Conversion Adapter and Fittings, and avoid giving a strong impact to them. Otherwise, breakage will result.
- If the existing system is installed on a DIN rail, the Base Adaptor is not necessary. The Q Series or iQ-R Series Base Module you use can be mounted onto a DIN rail.

### 4.2 Use Precautions

Item	AnS Series → Q Series	AnS Series → iQ-R Series
Width dimension of module	<p>Because the module is reduced in width dimension (34.5mm→27.4mm) and thus in area available for wiring, check dimensional data before installing the module.</p> <p>Unit: mm</p>	<p>Because the module is reduced in width dimension (34.5mm→27.8mm) and thus in area available for wiring, check dimensional data before installing the module.</p> <p>Unit: mm</p>
Depth dimension of module	<p>Because the module is increased in depth dimension, check dimensional data before installing the module.</p> <p>Unit: mm</p>	<p>Because the module is increased in depth dimension, check dimensional data before installing the module.</p> <p>Unit: mm</p>
Terminal block cover	<p>The terminal block cover for AnS Series is bigger than the width of the Q Series Module. Therefore, it is necessary to replace it with the terminal block cover supplied with the converter adapter.</p> <p>Unit: mm</p>	<p>The terminal block cover for AnS Series is bigger than the width of the iQ-R Series Module. Therefore, it is necessary to replace it with the terminal block cover supplied with the converter adapter.</p> <p>Unit: mm</p>

### 4.3 Installation Environment

Refer to the manual supplied with the Q Series or iQ-R Series module you use.

- Q Series: QCPU User's Manual (SH-080483ENG)
- iQ-R Series: Safety Guidelines (IB-0800525E)

## 5. Part Names and Installation Method

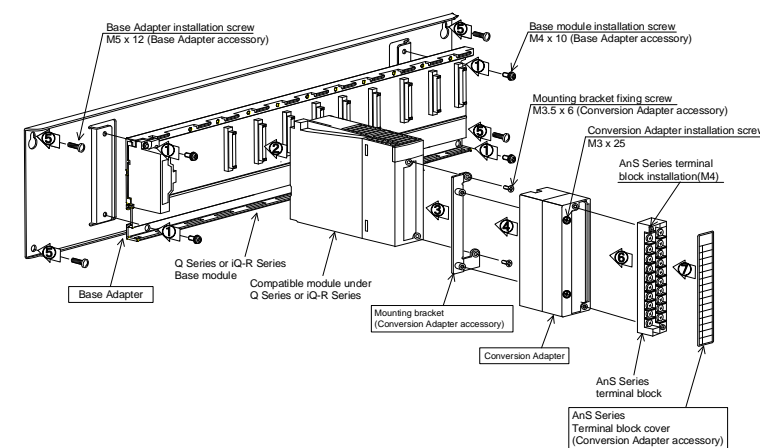

### 5.1 Installation Method

- Secure the Q Series or iQ-R Series Base Module to the Base Adapter with the supplied installation screws (M4 x 10). (Secure it in four places.)

#### Precaution

If the existing system is installed on a DIN rail, the Base Adaptor is not necessary. The Base Module you use can be mounted onto the DIN rail. Take note that a DIN rail installation adaptor made by Mitsubishi is required to mount Base Module onto a DIN rail. The separately-sold Conversion Adapter DIN rail Mounting Bracket (ERNT-ASQDIN□) is required to use the Conversion Adapter with a fixture on this Base module.

- Mount the Programmable Controller Module to the Base Module.
- Secure the mounting bracket to the Programmable Controller Module using the mounting bracket fixing screws (M3.5 x 6). (Secure it in two places, top and bottom.)
- Mount the Conversion Adapter onto the mounting bracket and secure it with the Conversion Adapter attaching screws (M3 x 25). (Secure it in two places, top and bottom.)

#### Precaution

Before tightening the installation screws, check that the Conversion Adapter has been securely installed on the Programmable Controller Module. Tightening the screws in floating-off state or tilting state will damage the Conversion Adapter installation screws and the mounting bracket.

- Secure the Base Adapter to the panel with the supplied attaching screws (M5 x 12). (Secure it in four places.)
- Secure the AnS Series terminal block to the Conversion Adapter with the supplied attaching screws (M4).
- Remove the terminal block cover from the AnS Series terminal block and fit the terminal block cover supplied with the Conversion Adapter in place.

### 5.2 Tightening Torque

Tighten the module installation screws to the specified torque below. An inappropriate tightening torque could cause the product to fall or result in a short circuit, product failure or malfunction.

Screw Location	Tightening Torque Range
Base Adapter installation screw (M5 screw)	2.75 to 3.63N·m
Base module installation screw (M4 screw)	1.39 to 1.89N·m
Mounting bracket fixing screw (M3.5 screw)	0.68 to 0.92N·m
Conversion adapter installation screw (M3 screw)	0.43 to 0.57N·m
AnS series terminal block installation screw (M4 screw)	0.78 to 1.18N·m

## 6. External Dimensions

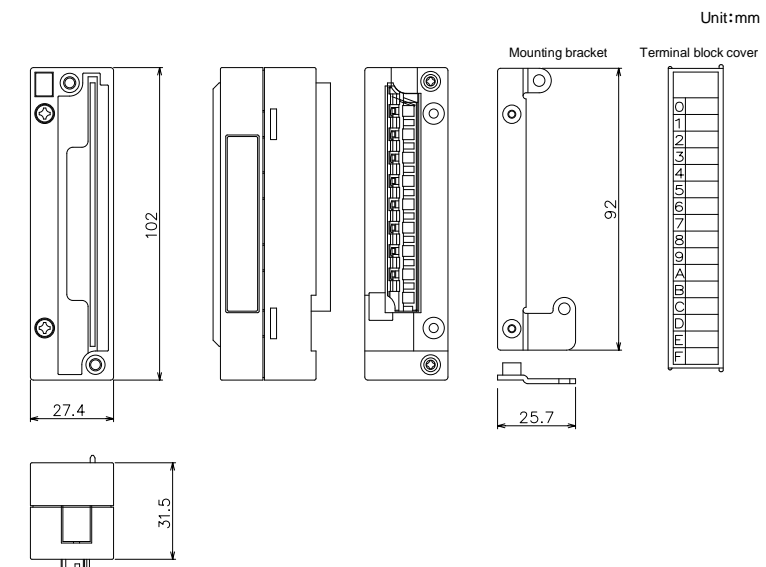

### Duplication Prohibited

This manual may not be reproduced in any form, in part or in whole, without written permission from Mitsubishi Electric Engineering Company Limited.  
©2018 MITSUBISHI ELECTRIC ENGINEERING COMPANY LIMITED ALL RIGHTS RESERVED

MELSEC is a registered trademark of Mitsubishi Electric Corporation in Japan.

### Product Warranty Details

Please confirm the following product warranty details prior to product use.

#### Gratis Warranty Terms and Gratis Warranty Range

If any fault or defect (hereinafter referred to as "Failure") attributable to Mitsubishi Electric Engineering Company Limited (hereinafter referred to as "MEE") should occur within the gratis warranty period, MEE shall repair the product free of charge via the distributor from whom you made your purchase.

#### Gratis Warranty Period

The gratis warranty period of this product shall be one (1) year from the date of purchase or delivery to the designated place. Note that after manufacture and shipment from MEE, the maximum distribution period shall be six (6) months, and the gratis warranty period after manufacturing shall be limited to eighteen (18) months.

In addition, the gratis warranty period for repaired products shall not exceed the gratis warranty period established prior to repair.

#### Gratis Warranty Range

The gratis warranty range shall be limited to normal use based on the usage conditions, methods and environment, etc., defined by the terms and precautions, etc., given in the instruction manual, user's manual and caution labels on the product.

#### Warranty Period after Discontinuation of Production

- MEE shall offer product repair services (fee applied) for seven (7) years after production of the product has been discontinued. Discontinuation of production shall be reported via distributors.
- Product supply (including spare parts) is not possible after production has been discontinued.

#### Exclusion of Opportunity Loss and Secondary Loss from Warranty Liability

Regardless of the gratis warranty period, MEE shall not be liable for compensation for damages arising from causes not attributable to MEE, opportunity losses or lost profits incurred by the user due to Failures of MEE products, damages or secondary damages arising from special circumstances, whether foreseen or unforeseen by MEE, compensation for accidents, compensation for damages to products other than MEE products, or compensation for other work carried out by the user.

#### Changes in Product Specifications

The specifications given in the catalogs, manuals and technical documents are subject to change without notice.

This document is a new publication, effective April 2018. Specifications are subject to change without notice.