

Mitsubishi Electric Programmable Controller Upgrade Tool

Conversion Adapter

Model
ERNT-1AR68AD



50CM-D180322-B(1806)

MITSUBISHI ELECTRIC ENGINEERING COMPANY LIMITED
HEAD OFFICE: Huijic KUDAN BLDG. 1-13-5, KUDANKITA CHIYODA-KU, TOKYO 102-0073, JAPAN
NAGOYA ENGINEERING OFFICE: 139 SHIMOYASHIKI-KO-SHIMOMAYASHIKI, KASUGAI, AICHI 486-0906, JAPAN

SAFETY PRECAUTIONS

(Always read these precautions prior to use.)

Before using this product, please read this manual carefully and pay full attention to safety to ensure that the product is used correctly.

The precautions presented in this manual are concerned with this product only. For Programmable Controller system safety precautions, refer to "Safety Guidelines" for MELSEC iQ-R Series Modules.

If the equipment is used in a manner not specified by the manufacturer, the protection provided by the equipment may be impaired.

In this manual, the safety precautions are ranked as "WARNING" and "CAUTION."

WARNING

Indicates that incorrect handling may cause hazardous conditions, resulting in death or severe injury.

CAUTION

Indicates that incorrect handling may cause hazardous conditions, resulting in medium or minor injury and/or property damage.

Note that failure to observe the CAUTION level instructions may lead to a serious consequence according to the circumstances. Always follow the precautions of both levels because they are important to personal safety. Please keep this manual in an easy-to-access location for future reference, and be sure to provide the manual to the end user.

Precautions before using

CAUTION

- When replacing the MELSEC-A Series with the MELSEC iQ-R Series, be sure to refer to the Programmable Controller Module manuals to check the differences in performance, functionality, CPU input/output signals, buffer memory addresses and the like.

Installation Precautions

CAUTION

- Use the conversion adapter and conversion adapter anchor base in the environment conditions described in the general specifications in "Safety Guidelines" for MELSEC iQ-R Series Modules. Failure to do so could lead to electric shock, fire, malfunction or product failure or deterioration.
- Do not come in direct contact with the conductive area of the conversion adapter. Doing so could lead to system malfunction or failure.
- Fully secure the conversion adapter and conversion adapter anchor base using the installation screws, and tighten the installation screws securely within the specified torque range. Failure to do so could cause the conversion adapter and anchor base to fall, resulting in conversion adapter and conversion adapter anchor base damage.
- Always check for correct match between MELSEC iQ-R Series and the conversion adapter. Incorrect match can cause damage to the MELSEC iQ-R Series module.

Wiring Precautions

WARNING

- Be sure to shut off all phases of the external power supply before performing installation or wiring work. Failure to do so could result in electric shock or product damage.
- If you want to energize and run the unit after completing the installation and wiring work, be sure to close the terminal block cover attached to the MELSEC-A series terminal block. Failure to do so could result in electric shock.

CAUTION

- Properly wire the conversion adapter after verifying the specifications and terminal layout of the module to be used. Connecting a power supply with a different rating or improper wiring could lead to fire or product failure.
- Securely tighten the conversion adapter installation screws, conversion adapter anchor base installation screws and MELSEC-A series terminal block installation screws within the specified torque range. A loose screw may result in a short circuit, fire or malfunction. An excessively tightened screw may result in screw or conversion adapter damage, causing the conversion adapter to fall, a short circuit or product malfunction.
- Do not allow foreign matter such as cuttings or wiring shavings to enter the conversion adapter or module. Doing so could lead to fire, failure or malfunction.

Startup and Maintenance Precautions

WARNING

- Do not touch the terminals during energization. Doing so could result in electric shock or malfunction.
- Be sure to shut off all phases of the external power supply before cleaning and retightening the terminal screws. Failure to do so could lead to electric shock. Excessively tightened screws could result in conversion adapter or input/output module damage, causing the conversion adapter to fall, a short circuit or product malfunction.

CAUTION

- Do not disassemble or modify the conversion adapter. Doing so could lead to failure, malfunction, injury or fire.
- The conversion adapter case is made of resin. Do not drop or apply excessive impact to the case. Doing so could lead to conversion adapter damage.

Disposal Precautions

CAUTION

- When disposing of the product, treat it as industrial waste.

安全注意事项

(使用前请务必阅读)

使用本产品时, 请仔细阅读本手册, 并充分注意安全。正确地使用产品。
本手册中标注的注意事项仅记载了与本产品相关的内容。关于可编程控制器系统的安全注意事项, 请参阅MELSEC iQ-R系列的“安全使用”。

在本安全注意事项中, 安全注意事项的等级分为「警告」和「注意」。

警告

表示错误操作可能造成危险后果, 引起死亡或重伤事故。

注意

表示错误操作可能造成危险后果, 引起中度伤害, 轻伤及财产损失。

另外, 根据情况不同, 即使是「注意」中记载的事项, 也可能引发严重后果。不管哪个记载的都是非常重要的内容, 请务必遵守。
请妥善保管本手册, 以便需要时取阅, 并请将该手册交给最终用户。

【使用前的注意事项】

注意

- 从 MELSEC-A 系列替换为 MELSEC iQ-R 系列时, 为了对性能、功能、针对 CPU 的输入输出信号、缓冲存储器地址等的差异进行确认, 必须参照对象可编程控制器模块的手册使用。

【安装注意事项】

注意

- 应在 MELSEC iQ-R 系列“安全使用”中记载的通用规格环境下使用转换适配器及转换适配器固定台。如果在一般规格范围以外的环境中使用, 可能导致触电、火灾、误动作、产品的损坏或劣化。
- 请不要直接接触转换适配器的导电部分。否则可能会造成系统误动作、故障。
- 转换适配器及转换适配器固定台应通过安装螺栓切实地加以固定。安装螺栓应在规定的扭矩范围内切实地拧紧。可能因掉落而导致转换适配器及转换适配器固定台被损。
- 请务必确认 MELSEC iQ-R 系列模块和转换适配器的组合是否正确。在错误组合下使用时, 可能会导致 MELSEC iQ-R 系列模块损坏。

【接线注意事项】

警告

- 必须将外部供应全相断开后再进行安装作业等。如果未全相断开, 可能会导致触电或产品损坏。
- 安装、配线作业完成之后再进行通电、运行时, 必须关闭 MELSEC-A 系列端子排的端子排盖板。如果未关闭端子排盖板, 可能会导致触电。

注意

- 请确认所使用模块的规格及端子排列后正确地进行转换适配器的接线。连接不符合额定值的电源或误配线, 会导致火灾或故障。
- 转换适配器安装螺栓、转换适配器固定台安装螺栓、MELSEC-A 系列端子排安装螺栓应在规定的扭矩范围内切实地拧紧。如果螺栓拧得过松, 会导致短路、火灾或误动作。如果螺栓拧得过紧, 有可能造成螺栓及转换适配器被损从而导致掉落、短路或误动作。
- 请注意不要让切屑或接线头等异物进入转换适配器及模块内。会导致火灾、故障、误动作。

【启动和维护注意事项】

警告

- 在通电状态下请勿触摸端子。可能会导致触电或误动作。
- 在清扫或重新紧固端子螺栓时, 必须将外部供应全相断开后再进行。如果未全相断开, 可能会导致触电。如果螺栓拧得过紧, 可能会造成转换适配器或输入/输出模块的破损从而导致掉落、短路或误动作。

注意

- 请不要拆卸、改造转换适配器。否则可能会导致故障、误动作、受伤或火灾。
- 转换适配器的外壳由树脂制成。因此请避免掉落或使其受到剧烈冲击。否则可能会损坏转换适配器。

【废弃注意事项】

注意

- 废弃时请将本产品作为工业废弃物处理。

EMC AND LOW VOLTAGE DIRECTIVES

Compliance to the EMC Directive, which is one of the EU Directives, has been a legal obligation for the products sold in European countries since 1996 as well as the Low Voltage Directive since 1997.

Manufacturers who recognize their products are compliant to the EMC and Low Voltage Directives are required to declare that print a "CE mark" on their products.

Authorized representative in Europe

Authorized representative in Europe is shown below.
Name: Mitsubishi Electric Europe B.V.
Address: Mitsubishi-Electric-Platz 1, 40882 Ratingen, Germany

1. Overview

This manual describes the Mitsubishi Electric Programmable Controller Upgrade Tool conversion adapter (ERNT-1AR68AD). The conversion adapter is a product that converts the differences in MELSEC-A series (hereinafter called A Series) and MELSEC iQ-R series (hereinafter called iQ-R Series) pin assignments.

When replacing the A Series with the iQ-R Series, be sure to refer to the Programmable Controller Module manuals to check the differences in performance, functionality, CPU input/output signals, buffer memory addresses and the like. Once you have opened the packaging, verify that it contains the following products.

Product	Shape	Quantity
Conversion adapter		1
Mounting bracket		1
Mounting bracket fixing screw (M3.5 x 6)		2
This manual	—	1

2. Specifications

2.1 General Specifications

Item	Specifications					
Operating ambient temperature	0 to 55°C (Maximum surrounding air temperature 55°C)					
Storage ambient temperature	-25 to 75°C					
Operating ambient humidity	5 to 95%RH, non-condensing					
Storage ambient humidity						
Vibration resistance	Compliant with JIS B 3502 and IEC 61131-2	Under intermittent vibration	Frequency	Constant acceleration	Half amplitude	
			5 to 8.4Hz	—	3.5mm	
		Under continuous vibration	8.4 to 150Hz	9.8m/s ²	—	10 times each in X, Y, Z directions
			5 to 8.4Hz	—	1.75mm	
8.4 to 150Hz	4.9m/s ²	—	—			
Shock resistance	Compliant with JIS B 3502 and IEC 61131-2 (147 m/s ² , 3 times each in 3 directions X, Y, Z)					
Operating atmosphere	No corrosive gases					
Operating altitude *1	0 to 2000m					
Installation location	Inside a control panel *2					
Overvoltage category *3	II or less					
Pollution degree *4	2					

- *1: Do not use or store under pressure higher than the atmospheric pressure of altitude 0m.
- *2: The enclosure is suitably designed for those specific environmental conditions, as applicable, and enclosure rate meets IP20 and minimum type 1 of UL 50.
- *3: This indicates the section of the power supply to which the equipment is assumed to be connected between the public electrical power distribution network and the machinery within premises. Category II applies to equipment for which electrical power is supplied from fixed facilities.
- *4: This index indicates the degree to which conductive material is generated in terms of the environment in which the equipment is used. Pollution level 2 is when only non-conductive pollution occurs. A temporary conductivity caused by condensing must be expected occasionally.

2.2 Hardware Specifications

Item	Specifications
Rated voltage / current	±15VDC, 30mA

3. Conversion Adapter Product Specifications

For detail specifications which do not appear in the specification comparison charts contained herein, see the user's manual supplied with the MELSEC iQ-R Series module you use. Also, check that the specifications of the connected devices meet the specifications of the MELSEC iQ-R Series Module.

Conversion Adapter Model	A Series Module Model	Number of analog input points	iQ-R Series Module Model	Conversion Adapter Weight (g)
ERNT-1AR68AD	A68AD (voltage input)	8 points (8 channels)	R60ADV8	135
	A68AD (current input)		R60ADI8	
	A68AD-S2 (voltage input)		R60ADV8	
	A68AD-S2 (current input)		R60ADI8	

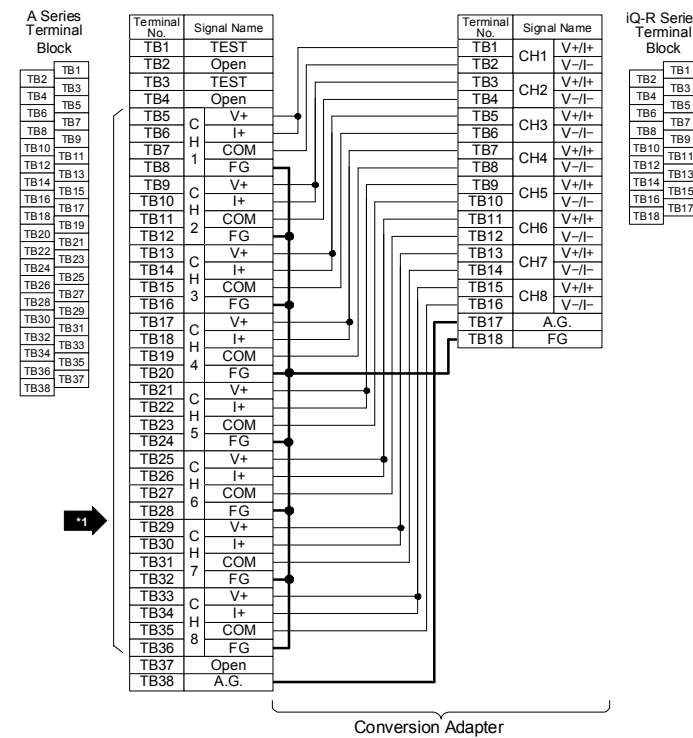

Precautions for wiring

With R60ADV8, R60ADI8 analog input, voltage input and current input cannot be used together in a single module.

< Specification Comparison Chart >

Specifications		Model		
		A Series	iQ-R Series	
Analog input	Voltage	A68AD, A68AD-S2 -10 to 0 to 10VDC (Input resistance hardware version K or later: 1MΩ; hardware version J or earlier: 30kΩ)	R60ADV8 -10 to 10VDC (input resistance: 1MΩ)	R60ADI8 —
	Current	4 to 20mA DC (input resistance: 250Ω)	—	0 to 20mA DC (input resistance: 250Ω)
Digital output		ACPU: 16-bit signed binary (-2048 to +2047) K2ACPU: Signed +16 bit binary (± 2047)	16-bit signed binary (-32768 to 32767)	
input/output characteristics	Voltage	Analog Input	Analog Input Range	
		+10V	0 to 10V	
		+5V or +20mA	0 to 5V	
		0V or +4mA	1 to 5V	
		-5V or -12mA	1 to 5V(extended mode)	
Maximum resolution	Current	-10V	-10 to 10V	
		-2000	-32000 to 32000	
		—	User range setting	
		—	0 to 20mA	
		—	4 to 20mA	
Overall accuracy		±1.0% (±20)	Ambient temperature 25±5°C: within ±0.1%(±32digit) Ambient temperature 0 to 55°C: within ±0.3%(±96digit)	
Maximum conversion speed		Maximum 2.5ms/channel	80μs/channel	
Absolute maximum	Voltage	±15V	±15V	
	Current	±30mA	—	
Number of analog input points		8 channels/module	8 channels/module	
Isolation method	Between input terminal and PLC power supply	Photocoupler isolation		Photocoupler isolation
	Between channels	Non-isolated		Non-isolated
No. of occupied points		32 points	16 points	
Connected terminal block		38-point terminal block	18-point terminal block	
Current consumption		Hardware version K or later: 0.39A Hardware version J or earlier: 0.9A	0.23A	0.22A

Make sure the section of the above table meets the specification of the machines and equipment connected to the iQ-R Series module.

Precautions for programming

- R60ADV8/R60ADI8 does not have an offset/gain setting terminal. For offset/gain setting, refer to the R60ADV8/R60ADI8 user's manual.
- For A68AD and A68AD-S2, R60ADV8/R60ADI8 conversion speed is slower. As a result, the possibility exists that noise that did not occur with A68AD or A68AD-S2 may occur with R60ADV8/R60ADI8 as an analog signal. In such a case, remove the noise using the average processing function.
- Program changes (changes to the number of occupied input/output points, input/output signals, and buffer memory addresses) are required.

4. Products Required by the Conversion Adapter

(1) Conversion Adapter Anchor Base (Sold Separately)

The conversion adapter anchor base secures the bottom of the conversion adapter and is required for conversion adapter use. One anchor base is required per base.

Conversion Adapter Anchor Base Model	Specifications	
	Type	Weight (g)
ERNT-1AR12F	12-slot conversion adapter anchor base	775
ERNT-1AR8F	8-slot conversion adapter anchor base	540
ERNT-1AR5F	5-slot conversion adapter anchor base	360

(2) Base Adapter (Sold Separately)

The base adapter enables iQ-R series installation using the installation holes of the A series base unit. (Additional hole machining not required)

Base Adapter Model	Specifications			
	A Series Compliant Module	iQ-R Series Compliant Module	Conversion Adapter Anchor Base	Weight (g)
ERNT-AQB38N	A38B, A38B-UL, A38B-E A38HB, A38HBEU	R312B R38B	ERNT-1AR12F	970
ERNT-AQB68N	A68B, A68B-UL	R612B R68B	ERNT-1AR8F	930
ERNT-AQB58N	A58B, A58B-UL	R68B	ERNT-1AR8F	870
ERNT-AQB35N	A35B, A35B-UL, A35B-E	R38B R35B	ERNT-1AR8F ERNT-1AR5F	795
ERNT-AQB65N	A65B, A65B-UL	R65B	ERNT-1AR8F	790
ERNT-AQB55N	A55B, A55B-UL		ERNT-1AR5F	655

5. Mounting and Installation

5.1 Handling Precautions

- Do not touch the terminals during energization. Doing so could result in electric shock or malfunction.
- Do not disassemble or modify the conversion adapter. Doing so could result in failure, malfunction, injury or fire.
- Do not come in direct contact with the conductive area of the conversion adapter. Doing so could result in system malfunction or failure.
- Fully secure the conversion adapter and conversion adapter anchor base using the installation screws, and securely tighten the screws within the specified torque range. Failure to do so could cause the conversion adapter and anchor base to fall, resulting in conversion adapter and conversion adapter anchor base damage.
- Conversion Adapter is intended for indoor use only.

5.2 Use Precautions

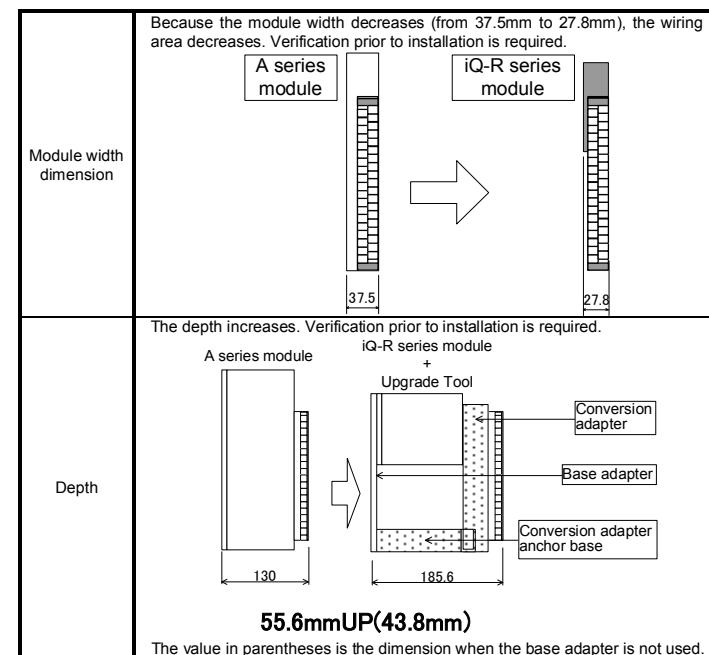

5.3 Installation Environment

Refer to "Safety Guidelines" for iQ-R Series Modules.

5.4 Wiring module power source

External connection to 24VDC power supply circuit of Conversion Adapter must be powered from approved source that meets of SELV/PELV, Class 2, and limited energy according to UL 61010-2-201.

6. Part Names and Installation Method

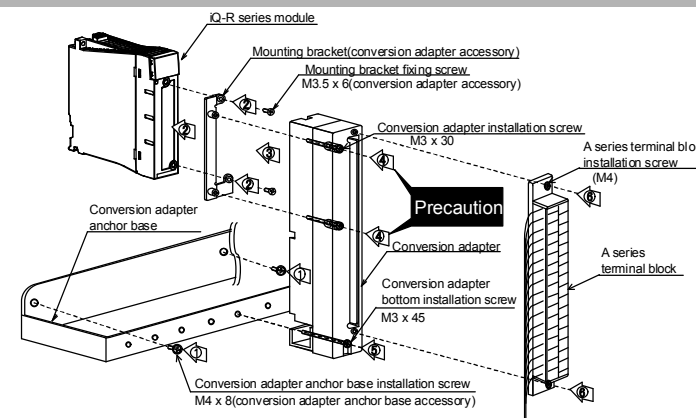

6.1 Installation Method

- Secure the conversion adapter anchor base to the base adapter or control panel using the conversion adapter anchor base installation screws (M4 × 8; 2 locations at both sides, 1 location at the center) provided as an accessory.
- Secure the mounting bracket to the Programmable Controller Module using the mounting bracket fixing screws (M3.5 × 6; 2 upper/lower locations).
- Mount the conversion adapter onto the mounting bracket.
- Secure the conversion adapter using the conversion adapter installation screws (M3 × 30; 2 locations).

Precaution
Before tightening the installation screws, check that the Conversion Adapter has been securely installed on the Programmable Controller Module. Tightening the screws in floating-off state or tilting state will damage the Conversion Adapter installation screws and the mounting bracket.

- Secure the conversion adapter using the conversion adapter bottom installation screw (M3 × 45; 1 location).
- Secure the A series terminal block to the conversion adapter using the terminal block installation screws (M4; two upper/lower locations).

6.2 Tightening Torque

Tighten the module installation screws to the specified torque below. An inappropriate tightening torque could cause the product to fall or result in a short circuit, product failure or malfunction.

Screw Location	Tightening Torque Range
Conversion adapter anchor base installation screw (M4 screw)	1.39 to 1.89 N·m
Mounting bracket fixing screw (M3.5 screw)	0.68 to 0.92 N·m
Conversion adapter bottom installation screw (M3 screw)	0.43 to 0.57 N·m
Conversion adapter installation screw (M3 screw)	
A series terminal block installation screw (M4 screw)	1.02 to 1.38 N·m

7. External Dimensions

Unit: mm

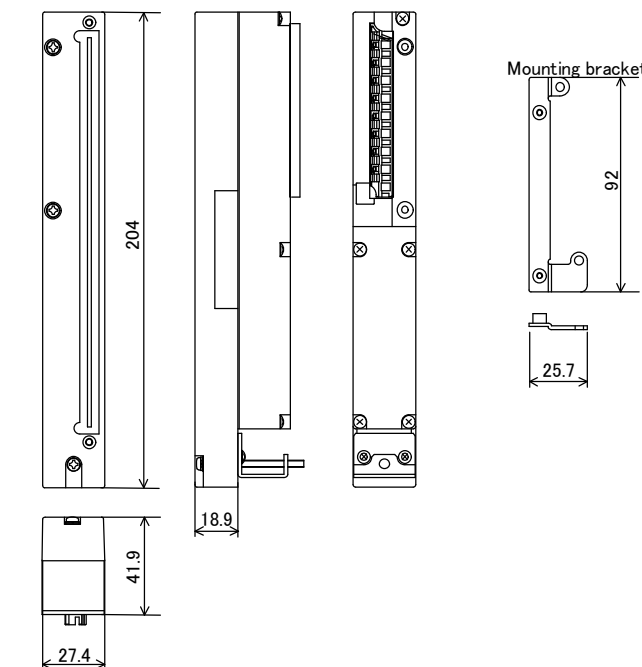

Duplication Prohibited
This manual may not be reproduced in any form, in part or in whole, without written permission from Mitsubishi Electric Engineering Company Limited.
©2018 MITSUBISHI ELECTRIC ENGINEERING COMPANY LIMITED ALL RIGHTS RESERVED

MELSEC is a registered trademark of Mitsubishi Electric Corporation in Japan.

Product Warranty Details

Please confirm the following product warranty details prior to product use.

Gratis Warranty Terms and Gratis Warranty Range

If any fault or defect (hereinafter referred to as "Failure") attributable to Mitsubishi Electric Engineering Company Limited (hereinafter referred to as "MEE") should occur within the gratis warranty period, MEE shall repair the product free of charge via the distributor from whom you made your purchase.

- Gratis Warranty Period**
The gratis warranty period of this product shall be one (1) year from the date of purchase or delivery to the designated place. Note that after manufacture and shipment from MEE, the maximum distribution period shall be six (6) months, and the gratis warranty period after manufacturing shall be limited to eighteen (18) months. In addition, the gratis warranty period for repaired products shall not exceed the gratis warranty period established prior to repair.
- Gratis Warranty Range**
The gratis warranty range shall be limited to normal use based on the usage conditions, methods and environment, etc., defined by the terms and precautions, etc., given in the instruction manual, user's manual and caution labels on the product.

Warranty Period after Discontinuation of Production

- MEE shall offer product repair services (fee applied) for seven (7) years after production of the product has been discontinued. Discontinuation of production shall be reported via distributors.
- Product supply (including spare parts) is not possible after production has been discontinued.

Exclusion of Opportunity Loss and Secondary Loss from Warranty Liability

Regardless of the gratis warranty period, MEE shall not be liable for compensation for damages arising from causes not attributable to MEE, opportunity losses or lost profits incurred by the user due to Failures of MEE products, damages or secondary damages arising from special circumstances, whether foreseen or unforeseen by MEE, compensation for accidents, compensation for damages to products other than MEE products, or compensation for other work carried out by the user.

Changes in Product Specifications

The specifications given in the catalogs, manuals and technical documents are subject to change without notice.

This document is a new publication, effective June 2018. Specifications are subject to change without notice.