

Mitsubishi Electric Programmable Controller Upgrade Tool

Conversion Adapter

Model ERNT-ASQT20

User's Manual



50CM-D180420-B(2006)

MITSUBISHI ELECTRIC ENGINEERING COMPANY LIMITED

HEAD OFFICE: HUIIC KUDAN BLDG.1-13-5, KUDANKITA CHIYODA-KU, TOKYO 102-0073, JAPAN
NAGOYA ENGINEERING OFFICE: 139 SHIMOYASHIKICHO-SHIMOYASHIKI, KASUGAI, AICHI 486-0906, JAPAN

SAFETY PRECAUTIONS

(Always read these precautions prior to use.)

Before attempting to use the Conversion Adapter (or the Products), read all instructions contained in this manual carefully to ensure safe and correct operation. The safety instructions appearing in this manual are limited to those that apply to the Products. For safety instructions to be heeded in regard to your programmable controller system as a whole, refer to the following manuals.

- MELSEC-Q series: QCPU User's Manual (SH-080483ENG)
- MELSEC iQ-R series: Safety Guidelines (IB-0800525E)

If the equipment is used in a manner not specified by the manufacturer, the protection provided by the equipment may be impaired.

In this manual, the safety precautions are ranked as "WARNING" and "CAUTION."

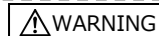

WARNING Indicates that incorrect handling may cause hazardous conditions, resulting in death or severe injury.

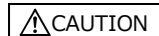

CAUTION Indicates that incorrect handling may cause hazardous conditions, resulting in medium or minor injury and/or property damage.

Note that failure to observe the CAUTION level instructions may lead to a serious consequence according to the circumstances. Always follow the precautions of both levels because they are important to personal safety. Please keep this manual in an easy-to-access location for future reference, and be sure to provide the manual to the end user.

Precautions before using



- When making a switch to the MELSEC-Q Series or MELSEC iQ-R Series, be sure to consult user's manual supplied with individual module under the MELSEC-Q Series or MELSEC iQ-R Series to confirm differences in various aspects including performance, function, CPU input/output signals between the two modules.

Installation Precautions



- Use the Conversion Adapter in the environmental conditions that are specified in the general specification in the following manuals. If the Products are used in an environment beyond the bounds of the general specification, electric shock, fire, malfunction, or damage to or degradation of the Products will result.
 - MELSEC-Q Series: QCPU User's Manual (SH-080483ENG)
 - MELSEC iQ-R Series: Safety Guidelines (IB-0800525E)
- Do not directly touch any conductive parts of Conversion Adapter. Contact will cause malfunction or failure in the system.
- Fasten the Conversion Adapter and the Mounting Bracket securely with retaining screws, and tighten the screws by applying torque within specified limits. Loose screws can lead to the dropping of the Conversion Adapter or Mounting Bracket, possibly causing breakage thereof. Excessive tightness of the screws can lead to breakage of the screws, Conversion Adapter, Mounting Bracket, or MELSEC-Q Series Module, possibly causing the dropping, shorting, and malfunction thereof.
- When installing the Conversion Adapter, take care not to get your hand snagged on the Mounting Bracket or the like. Injury may result.
- When installing or removing the MELSEC-Q Series or MELSEC iQ-R Series Module complete with a Converter Adapter, be sure to hold it with both hands. Dropping may lead to breakage.

Wiring Precautions



- Before attempting to install the Unit or carry out the necessary wiring, make certain that the external power supply, used in the system, is shut off on all three phases. Failure to do so may result in electric shock or damage to the product.
- After installation and wiring, close the terminal block cover before turning on the module for operation. Failure to do so may result in electric shock.



- Carry out wiring for the Conversion Adapter correctly after checking the specification and terminal arrangement for the module used. Connecting a power supply with a different voltage rating or incorrect wiring may cause a fire or failure.
- Tighten the terminal installation screws and terminal screw securely by applying torque within the specified limits. Loose screws will cause short circuit, fire or malfunction. Excessive tightening will damage the screws or the Conversion Adapter which in turn will cause dropping of parts, short circuit or malfunction.
- Use care to prevent foreign materials including cuttings and wiring debris from entering the Conversion Adapter or the MELSEC-Q Series Module. These will be cause for fire, failure or malfunction.

Startup and Maintenance Precautions



- Do not touch live terminals. There is a danger of electric shock or malfunction.
- Shut off the external power supply for the system in all phases before cleaning or retightening the terminal screws. Failure to do so may result in electric shock or causing the MELSEC-Q Series or MELSEC iQ-R Series module to fail or malfunction. Loose screws can lead to dropping, shorting, and malfunction. Excessive tightness of the screws can lead to breakage of the screws, converter adapter, fittings, or MELSEC-Q Series or MELSEC iQ-R Series Module, possibly causing the dropping, shorting, and malfunction thereof.

CAUTION

- Do not modify the Conversion Adapter or take it apart. Doing so will cause failure, malfunction, personal injury, or fire.
- The Conversion Adapter comes in a resin case. Do not drop the Adapter or give a strong impact to it. This will cause damage to the Adapter.

Disposal Precautions

CAUTION

- When disposing of the product, treat it as industrial waste.

EMC AND LOW VOLTAGE DIRECTIVES
Compliance to the EMC Directive, which is one of the EU Directives, has been a legal obligation for the products sold in European countries since 1996 as well as the Low Voltage Directive since 1997. Manufacturers who recognize their products are compliant to the EMC and Low Voltage Directives are required to declare that print a "CE mark" on their products.

Authorized representative in Europe
Authorized representative in Europe is shown below.
Name: Mitsubishi Electric Europe BV
Address: Mitsubishi-Electric-Platz 1, 40882 Ratingen, Germany

1. Overview

This manual describes the Mitsubishi Electric Programmable Controller Upgrade Tool conversion adapter (ERNT-ASQT20). When replacing the current module with the MELSEC-Q Series or the MELSEC iQ-R Series, be sure to refer to the Programmable Controller Module manuals to check the differences in performance, functionality, CPU input/output signals, buffer memory addresses and the like. Once you have opened the packaging, verify that it contains the following products.

Product	Shape	Qty	Product	Shape	Qty
Conversion Adapter		1	Mounting bracket fixing screws (M3.5x6)		2
Mounting bracket		1	Terminal block		1
			This manual	-	1

2. Specifications

2.1 General Specifications

Item	Specifications
Operating ambient temperature	0 to 55°C (Maximum surrounding air temperature 55°C)
Storage ambient temperature	-25 to 75°C
Operating ambient humidity	5 to 95%RH, non-condensing
Storage ambient humidity	
Vibration resistance	Compliant with JIS B 3502 and IEC 61131-2
Shock resistance	Compliant with JIS B 3502 and IEC 61131-2 (147m/s ² , 3 times each in 3 directions X, Y, Z)
	No corrosive gases
Operating atmosphere	0 to 2000m
Operating altitude *1	Inside a control panel *2
Installation location	II or less
Overvoltage category *3	2
Pollution degree *4	2

- Do not use or store under pressure higher than the atmospheric pressure of altitude 0m.
- The enclosure is suitably designed for those specific environmental conditions, as applicable, and enclosure rate meets IP20 and minimum type 1 of UL 50.
- This indicates the section of the power supply to which the equipment is assumed to be connected between the public electrical power distribution network and the machinery within premises. Category II applies to equipment for which electrical power is supplied from fixed facilities.
- This index indicates the degree to which conductive material is generated in terms of the environment in which the equipment is used. Pollution level 2 is when only non-conductive pollution occurs. A temporary conductivity caused by condensing must be expected occasionally.

3. Conversion Adapter Product Specifications

For detail specifications which do not appear in the specifications of the MELSEC-Q Series Module or the MELSEC iQ-R Series Module, see the user's manual supplied with the Programmable Controller Module you use. Also, check that the specifications of the connected devices meet the specifications of the Programmable Controller Module.

(1) MELSEC-Q Series, MELSEC iQ-R Series module
The conversion adapter can be used in combination with the following MELSEC-Q or MELSEC iQ-R series module.

Input/Output	MELSEC-Q Series module model				
Input	QX10	QX28	QX40	QX40-S1	QX40H
Output	QY10	QY18A	QY22	QY40P	QY50
I/O Combined	QX48Y57	QY80			QY68A

Input/Output	MELSEC iQ-R Series module model				
Input	RX10	RX28	RX40C7	RX40PC6H	RX40NC6H
Output	RY10R2	RY18R2A	RY20S6	RY40NT5P	RY40PT5P

(2) Specifications of the terminal block (conversion adapter accessory)

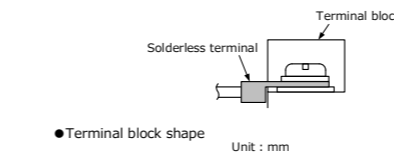
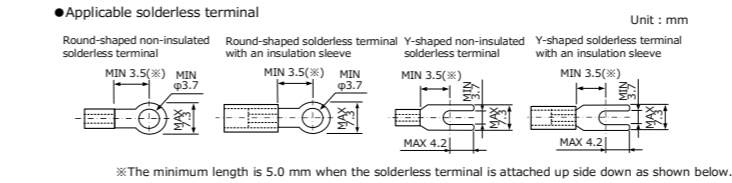

(3) Internal connection

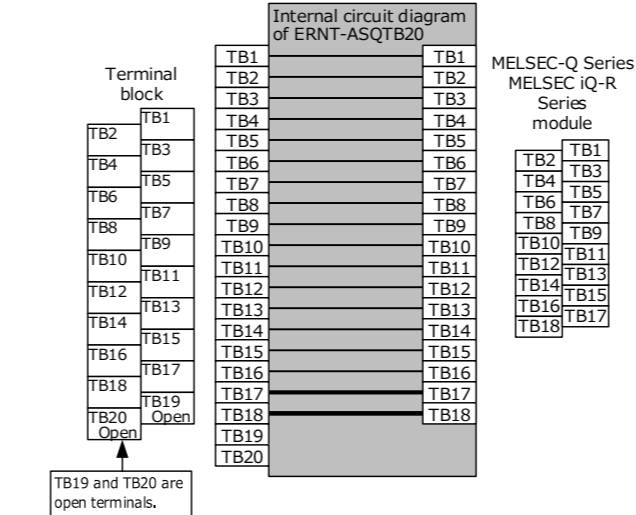

(4) External connection

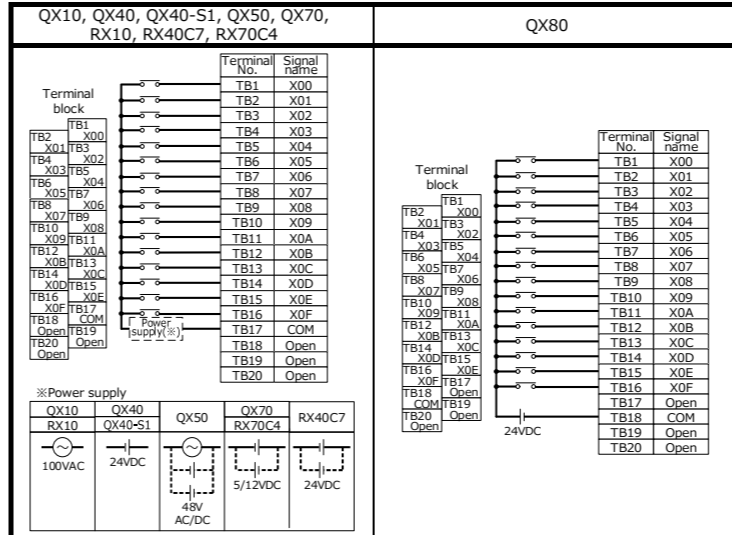

QX28, RX28

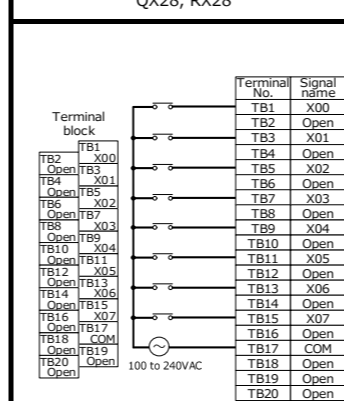

QX40H, QX70H, QX80H, QX90H, RX40PC6H, RX40NC6H

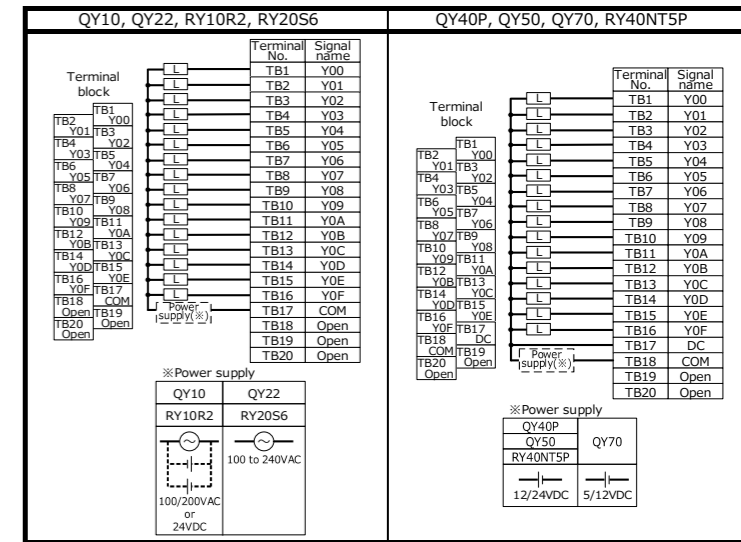
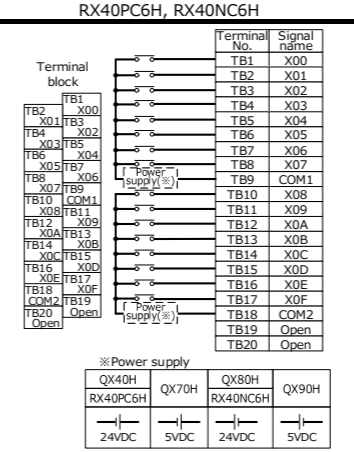

QY80, RY40PT5P

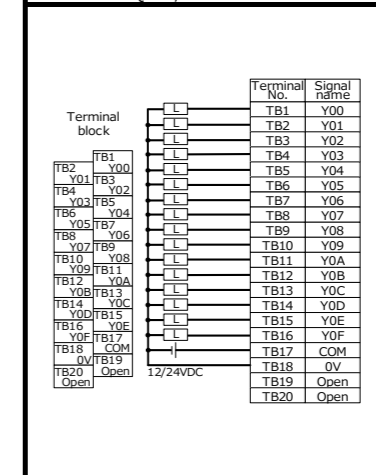

QY18A, RY18R2A

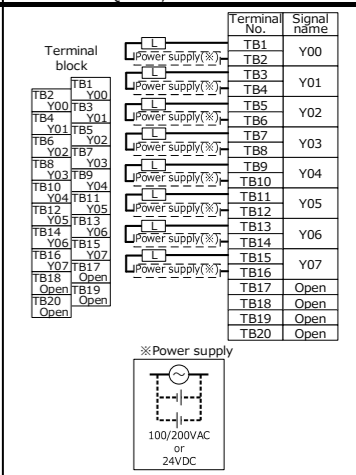

QY68A

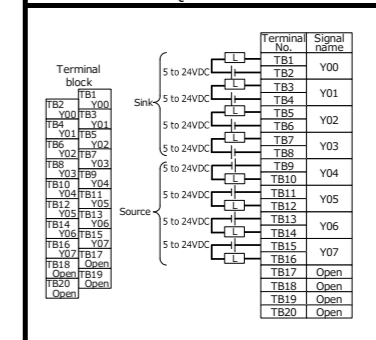

QX48Y57

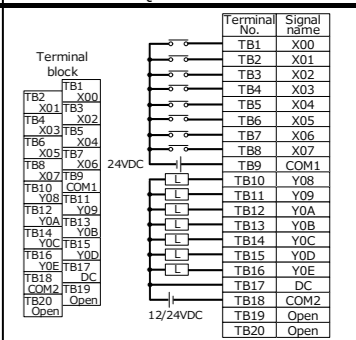

(5) MELSEC-Q Series module, MELSEC iQ-R Series module specification

① Input module

Specification	MELSEC-Q Series	
	QX10	QX28
Number of input points	16 points	8 points
Rated input voltage	100 to 120VAC (+10/-15%) 50/60Hz(±3Hz)	100 to 240VAC (+10/-15%) 50/60Hz(±3Hz)
Rated input current	Approx. 8mA(100VAC,60Hz) Approx. 7mA(100VAC,50Hz)	Approx. 1.7mA(200VAC,60Hz) Approx. 1.4mA(200VAC,50Hz) Approx. 8mA(100VAC,60Hz) Approx. 7mA(100VAC,50Hz)
Inrush current	Max. 200mA within 1ms (132VAC)	Max. 950mA within 1ms (264VAC)
ON voltage/ON current	80VAC or higher/ 5mA or higher(50Hz,60Hz)	80VAC or higher/ 5mA or higher(50Hz,60Hz)
OFF voltage/OFF current	30VAC or lower/ 1.7mA or lower(50Hz,60Hz)	30VAC or lower/ 1.7mA or lower(50Hz,60Hz)
Input impedance	Approx. 12kΩ(60Hz) Approx. 15kΩ(50Hz)	Approx. 12kΩ(60Hz) Approx. 15kΩ(50Hz)
Response time	OFF to ON 15ms or less (100VAC,50Hz,60Hz)	10ms or less (200VAC,50Hz,60Hz)
Isolation method	Photocoupler isolation	Photocoupler isolation
Internal current consumption (SVDC)	50mA (TYP. All points ON)	50mA (TYP. All points ON)
Wiring method for common	16 points/common	8 points/common

50CM-D180420-H03-B

Specification	MELSEC-Q Series					
	QX40 (Positive common)	QX40-S1 (Positive common)	QX50 (Positive/Negative shared common, AC)	QX70 (Positive/Negative shared common)	QX80 (Negative common)	QX40H (Positive common)
Number of input points	16 points	16 points	16 points	16 points	16 points	16 points
Rated input voltage	24VDC (+20/-15%)	24VDC (+20/-15%)	48VDC (+20/-15%) 50/60Hz(±3Hz)	5VDC(+20/-10%) 12VDC(+20/-15%)	24VDC (+20/-15%)	24VDC (+20/-15%)
Rated input current	Approx. 4mA	Approx. 6mA	Approx. 4mA	Approx. 1.2mA	Approx. 3.3mA	Approx. 6mA
ON voltage/ON current	19V or higher/ 3mA or higher	19V or higher/ 4.0mA or higher	28V or higher/ 2.5mA or higher	3.5V or higher/ 1mA or higher	19V or higher/ 3mA or higher	13V or higher/ 3mA or higher
OFF voltage/OFF current	11V or lower/ 1.7mA or lower	11V or lower/ 1.7mA or lower	10V or lower/ 1.0mA or lower	1V or lower/ 0.1mA or lower	11V or lower/ 1.7mA or lower	8V or lower/ 1.6mA or lower
Input resistance	Approx. 5.6kΩ	Approx. 3.9kΩ	Approx. 11.2kΩ	Approx. 3.3kΩ	Approx. 5.6kΩ	Approx. 3.9kΩ
Response time	OFF to ON 1/5/10/20/70ms or less ON to OFF 1/5/10/20/70ms or less	0.1/0.2/0.4/0.6/1ms or less 0.1/0.2/0.4/0.6/1ms or less	5ms or less 20ms or less	15ms or less 20ms or less	1/5/10/20/70ms or less 1/5/10/20/70ms or less	0.1/0.2/0.4/0.6/1ms or less 0.1/0.2/0.4/0.6/1ms or less
Isolation method	Photocoupler isolation	Photocoupler isolation	Photocoupler isolation	Photocoupler isolation	Photocoupler isolation	Photocoupler isolation
Internal current consumption (5VDC)	50mA (TYP. All points ON)	60mA (TYP. All points ON)	50mA (TYP. All points ON)	55mA (TYP. All points ON)	50mA (TYP. All points ON)	80mA (TYP. All points ON)
Wiring method for common	16 points/common	16 points/common	16 points/common	16 points/common	16 points/common	8 points/common

Specification	MELSEC-Q Series		
	QX70H (Positive common)	QX80H (Negative common)	QX90H (Negative common)
Number of input points	16 points	16 points	16 points
Rated input voltage	5VDC(+20/-15%)	24VDC(+20/-15%)	5VDC(+20/-15%)
Rated input current	Approx. 6mA	Approx. 6mA	Approx. 6mA
ON voltage/ON current	3.5V or higher/ 3mA or higher	13V or higher/ 3mA or higher	3.5V or higher/ 3mA or higher
OFF voltage/OFF current	1V or lower/ 1mA or lower	8V or lower/ 1.6mA or lower	1V or lower/ 1mA or lower
Input resistance	Approx. 470Ω	Approx. 3.9kΩ	Approx. 470Ω
Response time	OFF to ON 0.1/0.2/0.4/0.6/1ms or less ON to OFF 0.1/0.2/0.4/0.6/1ms or less	0.1/0.2/0.4/0.6/1ms or less 0.1/0.2/0.4/0.6/1ms or less	0.1/0.2/0.4/0.6/1ms or less 0.1/0.2/0.4/0.6/1ms or less
Isolation method	Photocoupler isolation	Photocoupler isolation	Photocoupler isolation
Internal current consumption (5VDC)	80mA (TYP. All points ON)	80mA (TYP. All points ON)	80mA (TYP. All points ON)
Wiring method for common	8 points/common	8 points/common	8 points/common

Specification	MELSEC iQ-R Series			
	RX10	RX28	RX40C7 (Positive/Negative Common Shared Type)	RX70C4 (Positive/Negative Common Shared Type)
Number of input points	16 points	8 points	16 points	16 points
Rated input voltage	100-120VAC (+10%/-15%) 50/60Hz(±3Hz)	100-240VAC (+10%/-15%) 50/60Hz(±3%)	24VDC (20.4 to 28.8VDC)	5VDC(4.25 to 6VDC) 12VDC(10.2 to 14.4VDC)
Rated input current	8.2mA (100VAC 60Hz) 6.8mA (100VAC 50Hz)	16.4mA (200VAC 60Hz) 13.7mA (200VAC 50Hz) 8.2mA (100VAC 60Hz) 6.8mA (100VAC 50Hz)	7.0mA TYP. (24VDC)	1.7mA TYP. (5VDC) 4.8mA TYP. (12VDC)
Inrush current	200mA maximum, with in 1ms	950mA maximum, with in 1ms	-	-
ON voltage/ON current	80VAC or higher/ 5mA or higher (50Hz, 60Hz)	80VAC or higher/ 5mA or higher (50Hz, 60Hz)	15V or higher/ 4mA or higher	3.5V or higher/1mA or higher
OFF voltage/OFF current	30VAC or lower/ 1.7mA or lower (50Hz, 60Hz)	30VAC or lower/ 1.7mA or lower (50Hz, 60Hz)	8V or lower/ 2mA or lower	1V or lower/0.1mA or lower
Input impedance	12.2kΩ (60Hz) 14.6kΩ (50Hz)	12.1kΩ (60Hz) 14.5kΩ (50Hz)	3.3kΩ	2.3kΩ
Response time	OFF to ON 15ms or less (100VAC 50Hz,60Hz) ON to OFF 20ms or less (100VAC 50Hz,60Hz)	10ms or less (200VAC 50Hz,60Hz) 20ms or less (200VAC 50Hz,60Hz)	0.1/0.2/0.4/0.6/1/5/10/20/70ms 0.35/0.4/0.5/0.7/1/5/10/20/70ms	0.2/0.3/0.4/0.5/1/5/10/20/70ms 0.41/0.5/0.6/0.7/1/5/10/20/70ms
Internal current consumption (5VDC)	110mA (TYP. All points ON)	90mA (TYP. All points ON)	110mA (TYP. All points ON)	100mA (TYP. All points ON)
Wiring method for common	16 points/common	8 points/common	16 points/common	16 points/common

② Output module

Specification	MELSEC-Q Series	
	QY10	QY18A
Number of output points	16 points	8 points
Rated switching voltage current	24VDC 2A(resistive load)/point 240VAC 2A(COSφ=1)/point 8A/common	24VDC 2A(resistive load)/point 240VAC 2A(COSφ=1)/point 8A/module
Minimum switching load	5VDC 1mA	5VDC 1mA
Maximum switching load	264VAC 125VDC	264VAC 125VDC
Response Time	OFF to ON 10ms or less ON to OFF 12ms or less	10ms or less 12ms or less
Surge suppressor	None	None
Fuse	None	None
Isolation method	Relay isolation	Relay isolation
Internal current consumption (5VDC)	430mA(TYP. all points ON)	240mA(TYP. all points ON)
Wiring method for common	16 points/common	All points independent

Specification	MELSEC-Q Series			
	QY22	QY40P(Sink type)	QY50(Sink type)	QY70(Sink type)
Number of output points	16 points	16 points	16 points	16 points
Rated load voltage	100 to 240VAC 50/60Hz±5%	12 to 24VDC (+20/-15%)	12 to 24VDC (+20/-15%)	5 to 12VDC (+25/-10%)
Maximum load current	0.6A/point, 4.8A/common	0.1A/point, 1.6A/common	0.5A/point, 4A/common	16mA/point, 256mA/common
Maximum inrush current	20A cycle or less	0.7A 10ms or less	4A 10ms or less	40mA 10ms or less
Leaked current at OFF	3mA or lower(240V 60Hz) 1.5mA or lower(120V 60Hz)	0.1mA or lower	0.1mA or lower	V _{OL} : 3.5VDC (V _{CC} =5VDC, I _{OL} =0.4mA)
Maximum voltage drop at ON	1.5V or lower	0.1VDC(TYP.)0.1A 0.2VDC(MAX.)0.1A	0.2VDC(TYP.)0.5A 0.3VDC(MAX.)0.5A	V _{OL} : DC0.3V
Response time	OFF to ON 1ms + 0.5 cycles or less ON to OFF 1ms + 0.5 cycles or less (rated load, resistive load)	1ms or less 1ms or less (rated load, resistive load)	1ms or less 1ms or less (rated load, resistive load)	0.5ms or less (resistive load)
Surge suppressor	CR absorber	Zener diode	Zener diode	None
Fuse	None	None	6.7A(unchangeable) (fuse capacity : 50A)	1.6A (unchangeable) (fuse capacity : 50A)
Protection function	None	Yes(overload protection, overheat protection)	None	None
Isolation method	Photocoupler isolation	Photocoupler isolation	Photocoupler isolation	Photocoupler isolation
Internal current consumption (5VDC)	250mA (MAX. All points ON)	65mA (TYP. All points ON)	80mA (TYP. All points ON)	95mA (TYP. All points ON)
Wiring method for common	16 points/common	16 points/common	16 points/common	16 points/ common

Specification	MELSEC-Q Series	
	QY68A(Sink/Source type)	QY80(Source type)
Number of output points	8 points	16 points
Rated load voltage	5 to 24VDC (+20/-10%)	12 to 24VDC(+20/-15%)
Maximum load current	2A/point, 8A/module	0.5A/point, 4A/common
Maximum inrush current	8A 10ms or less	4A 10ms or less
Leaked current at OFF	0.1mA or less	0.1mA or less
Maximum voltage drop at ON	0.3VDC (MAX.)2A	0.2VDC(TYP.)0.5A 0.3VDC(MAX.)0.5A
Response time	OFF to ON 3ms or less ON to OFF 10ms or less (resistive load)	1ms or less (rated load, resistive load)
Surge suppressor	Zener diode	Zener diode
Fuse	None	6.7A(unchangeable) (fuse capacity : 50A)
Protection function	None	None
Isolation method	Photocoupler isolation	Photocoupler isolation
Internal current consumption (5VDC)	110mA(TYP. All points ON)	80mA(TYP. All points ON)
Wiring method for common	All points independent	16 points/common

Specification	MELSEC iQ-R Series	
	RY10R2	RY18R2A
Number of output points	16 points	8 points
Rated switching voltage, current	24VDC 2A/point(resistance load) 240VAC 2A/point(COSφ=1) 8A/common	24VDC 2A/point(resistance load) 240VAC 2A/point(COSφ=1) 8A/module
Minimum switching load	5VDC 1mA	5VDC 1mA
Maximum switching voltage	264VAC 125VDC	264VAC 125VDC
Response time	OFF to ON 10ms or less ON to OFF 12ms or less	10ms or less 12ms or less
Surge suppressor	None	None
Fuse	None	None
Internal current consumption (5VDC)	450mA (TYP. All points ON)	260mA (TYP. All points ON)
Wiring method for common	16 points/common	All points independent

Specification	MELSEC iQ-R Series		
	RY20S6	RY40NT5P(Sink type)	RY40PT5P(source type)
Number of output points	16 points	16 points	16 points
Rated load voltage	100 to 240VAC(+10%/-15%), 50/60Hz(±3Hz)	12/24VDC (10.2 to 28.8VDC)	12/24VDC (10.2 to 28.8VDC)
Maximum load current	0.6A/point 4.8A/common	0.5A/point, Pilot Duty, 5A/common	0.5A/point, Pilot Duty, 5A/common
Minimum load voltage/current	24VAC 100mA 100VAC 25mA 240VAC 25mA	-	-
Maximum inrush current	20A cycle or lower	Current is to be limited by the overload protection function	Current is to be limited by the overload protection function
OFF leakage current	3mA or lower (240V 60Hz), 1.5mA or lower (120V 60Hz)	0.1mA or lower	0.1mA or lower
Maximum voltage drop at power-ON	1.5VAC or lower (at load current of 0.6A)	0.2VDC(TYP.) 0.5A, 0.3VDC(MAX.) 0.5A	0.2VDC(TYP.) 0.5A, 0.3VDC(MAX.) 0.5A
Response time	OFF to ON 1ms + 0.5 cycles or less ON to OFF 1ms + 0.5 cycles or less (rated load and resistive load)	0.5ms or less 1ms or less (rated load and resistive load)	0.5ms or less 1ms or less (rated load and resistive load)
Surge suppressor	CR absorber	Zener diode	Zener diode
Fuse	None (Attaching a fuse to each external wiring is recommended)	None	None
Internal current consumption (5VDC)	280mA(TYP. All points ON)	140mA (TYP. All points ON)	130mA (TYP. All points ON)
Wiring method for common	16 points/common	16 points/common	16 points/common

③ I/O Combined module

<Input specification>

Specification	Model	
	QX48Y57(Input specification)	Input(Positive common)
Number of input points	8 points	
Rated input voltage	24VDC (+20/-15%)	
Rated input current	Approx. 4mA	
ON voltage/ON current	19V or higher/3mA or higher	
OFF voltage/OFF current	11V or lower/1.7mA or lower	
Input resistance	Approx. 5.6kΩ	
Response time	OFF to ON 1/5/10/20/70ms or less ON to OFF 1/5/10/20/70ms or less	
Isolation method	Photocoupler isolation	
Internal current consumption (5VDC)	80mA(TYP. all points ON)	
Wiring method for common	8 points/common	

Specification	Model	
	QX48Y57(Output specification)	Output(Sink type)
Number of output points	7 points	
Rated load voltage	12 to 24VDC (+20/-15%)	
Maximum load current	0.5A/point, 2A/common	
Maximum inrush current	4A 10ms or less	
Leaked current at OFF	0.1mA or less	
Maximum voltage drop at ON	0.2VDC(TYP.)0.5A 0.3VDC(MAX.)0.5A	
Response time	OFF to ON 1ms or less ON to OFF 1ms or less(rated load, resistive load)	
Surge suppressor	Zener diode	
Fuse	4A(unchangeable)(fuse capacity : 50A)	
Protection function	No	
Isolation method	Photocoupler isolation	
Wiring method for common	7 points/common	

4. Mounting and Installation

4.1 Handling Precautions

- Before attempting to install the Unit or carry out the necessary wiring, make certain that the external power supply, used in the system, is shut off on all three phases. Failure to do so may result in electric shock or damage to the product.
- Do not touch live terminals. There is a danger of electric shock or malfunction.
- Do not modify the Conversion Adapter or take it apart. Doing so will cause failure, malfunction, personal injury, or fire.
- Do not touch the energized part of the Conversion Adapter directly. Contact will cause malfunction or failure in the system.
- Fully secure the conversion adapter and conversion adapter anchor base using the installation screws, and securely tighten the screws within the specified torque range. Failure to do so could cause the conversion adapter and anchor base to fall, resulting in conversion adapter and conversion adapter anchor base damage.
- Take care to prevent foreign materials including cutting chips and wire scraps from entering the Conversion Adapter or the Programmable Controller Module, possibly causing fire, failure or malfunction thereof.
- Do not drop the Conversion Adapter or do not give a strong impact to it. This will cause damage.
- Conversion Adapter is intended for indoor use only.

4.2 Use Precautions

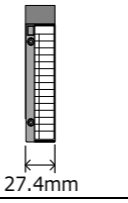
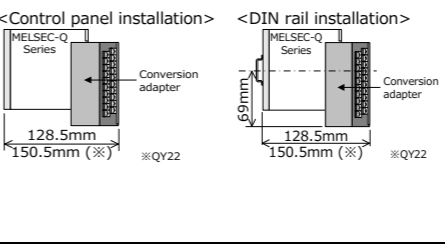
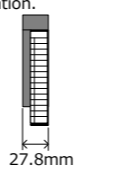
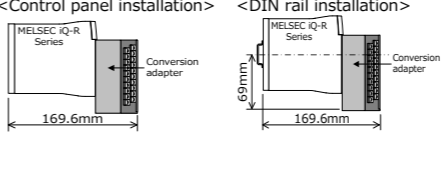
Item	Width dimension of module	Depth dimension
MELSEC-Q	The module width dimension is 27.4mm. Check the conditions for wiring space and installation. 	The depth required for installation is 128.5 mm (150.5 mm for QY22). Check the installation condition. <p><Control panel installation> <DIN rail installation></p> 
MELSEC iQ-R	The module width dimension is 27.8mm. Check the conditions for wiring space and installation. 	The depth required for installation is 169.6mm. Check the installation condition. <p><Control panel installation> <DIN rail installation></p> 

4.3 Installation Environment

- Refer to the manual supplied with the MELSEC-Q Series or MELSEC iQ-R Series module you use.
- MELSEC-Q Series: QCPU User's Manual (SH-080483ENG)
 - MELSEC iQ-R Series: Safety Guidelines (IB-0800525E)

5. Part Names and Installation Method

[Installation with the Control panel]

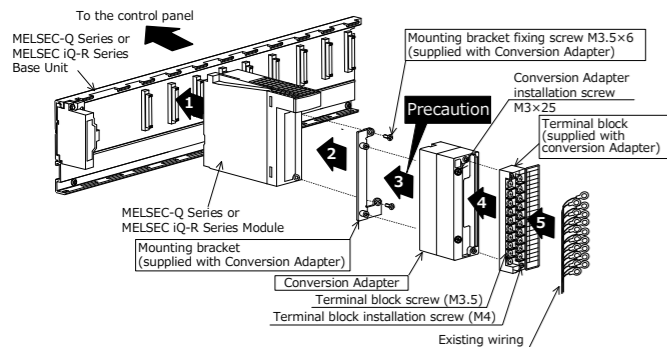

For using the conversion adapter with a fixture and the disconnection detector connector conversion cable for the temperature control module on the same base unit, use a separately-sold base adapter (ERNT-ASQB□□N). Refer to the user's manual of the base adapter for information on how to install the base adapter.

- | | |
|--------------------------------------|---|
| <Conversion Adapters with a fixture> | <Disconnection detector connector conversion cable> |
| ·ERNT-ASQT68AD-G | ·ERNT-ASQT64TCTTBW |
| ·ERNT-ASQT68TD-H01 | ·ERNT-ASQT64TCRTBW |
| ·ERNT-ASQT68TD-H02 | ·ERNT-ASQT62TCTTBW |
| ·ERNT-ASQTD61 | ·ERNT-ASQT62TCRTBW |
| ·ERNT-ASQTD62 | |
| ·ERNT-ASQTD62D | |

[Installation with the DIN rail]

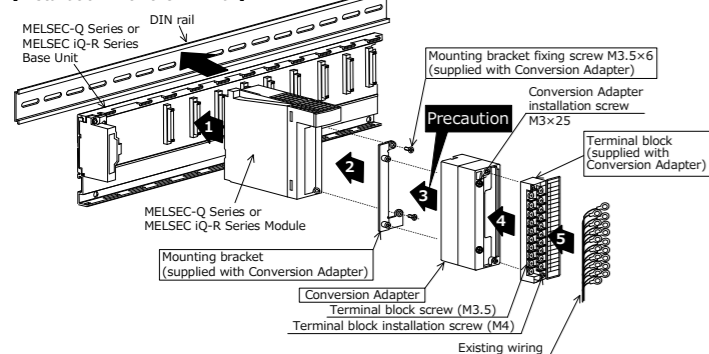

For using the conversion adapter with a fixture and the disconnection detector connector conversion cable for the temperature control module on the same base unit, use a separately-sold conversion adapter DIN rail mounting bracket (ERNT-ASQDIN□□□). Refer to the user's manual of the conversion adapter DIN rail mounting bracket for information on how to install the bracket.

- | | |
|--------------------------------------|---|
| <Conversion Adapters with a fixture> | <Disconnection detector connector conversion cable> |
| ·ERNT-ASQT68AD-G | ·ERNT-ASQT64TCTTBW |
| ·ERNT-ASQT68TD-H01 | ·ERNT-ASQT64TCRTBW |
| ·ERNT-ASQT68TD-H02 | ·ERNT-ASQT62TCTTBW |
| ·ERNT-ASQTD61 | ·ERNT-ASQT62TCRTBW |
| ·ERNT-ASQTD62 | |
| ·ERNT-ASQTD62D | |

5.1 Installation Method

Installation with the Control panel

Mount the MELSEC-Q Series or MELSEC iQ-R Series Base Unit to the control panel.

For how to mount the Base Unit to the control panel, refer to the following.

- MELSEC-Q series: QCPU User's Manual (SH-080483ENG)
- MELSEC iQ-R series: MELSEC iQ-R Module Configuration Manual (SH-081262ENG)

Installation with the DIN rail

Mount the DIN rail mounting adapter manufactured by Mitsubishi Electric to the MELSEC-Q Series or MELSEC iQ-R Series Base Unit.

For how to mount the DIN rail mounting adapter to the DIN rail, refer to the following.

- MELSEC-Q series: QCPU User's Manual (SH-080483ENG)
- MELSEC iQ-R series: MELSEC iQ-R Module Configuration Manual (SH-081262ENG)

- Install the Programmable Controller Module to the MELSEC-Q Series or MELSEC iQ-R Series Base Unit. In addition, remove the terminal block attached with the Programmable Controller Module after loosening the terminal block installation screws (2 places up and down).

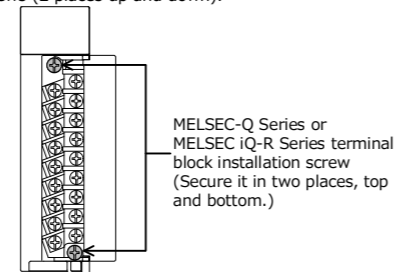

- Secure the mounting bracket to the Programmable Controller Module using the mounting bracket fixing screws (M3.5 × 6). (2 places)

- Install the Conversion Adapter to the mounting bracket, and secure it using the Conversion Adapter installation screws (M3 × 25). (2 places)

Precaution

Before tightening the installation screws, check that the Conversion Adapter has been securely installed on the Programmable Controller Module. Tightening the screws in floating-off state or tilting state will damage the Conversion Adapter installation screws and the mounting bracket.

- Secure the terminal block to the Conversion Adapter with the supplied terminal block installation screw (M4). (2 places, top and bottom.)

- Connect the existing wiring to the terminal block.
When any wires are left unconnected, connect them to open terminals or insulate them.

5.2 Tightening Torque

Tighten the module installation screws to the specified torque below. An inappropriate tightening torque could cause the product to fall or result in a short circuit, product failure or malfunction.

Screw Location	Tightening Torque Range
Mounting bracket fixing screw (M3.5×6)	0.68 to 0.92 N·m
Conversion adapter installation screw (M3×25)	0.43 to 0.57 N·m
Terminal block installation screw (M4 screw)	0.78 to 1.18 N·m
Terminal block screw (M3.5 screw)	0.59 to 0.88 N·m

6. External Dimensions

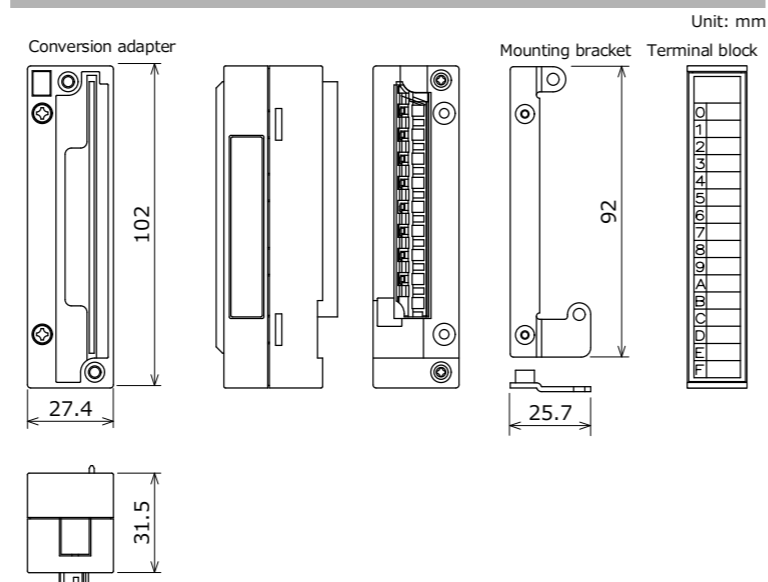

Weight: 140g

Duplication Prohibited

This manual may not be reproduced in any form, in part or in whole, without written permission from Mitsubishi Electric Engineering Company Limited.
©2018 MITSUBISHI ELECTRIC ENGINEERING COMPANY LIMITED ALL RIGHTS RESERVED

MELSEC and MELSEC iQ-R is a registered trademark of Mitsubishi Electric Corporation in Japan.
ERNT is a registered trademark of Mitsubishi Electric Engineering Company Limited in Japan.

Product Warranty Details

Please confirm the following product warranty details prior to product use.

Gratis Warranty Terms and Gratis Warranty Range

If any fault or defect (hereinafter referred to as "Failure") attributable to Mitsubishi Electric Engineering Company Limited (hereinafter referred to as "MEE") should occur within the gratis warranty period, MEE shall repair the product free of charge via the distributor from whom you made your purchase.

Gratis Warranty Period

The gratis warranty period of this product shall be one (1) year from the date of purchase or delivery to the designated place.

Note that after manufacture and shipment from MEE, the maximum distribution period shall be six (6) months, and the gratis warranty period after manufacturing shall be limited to eighteen (18) months.

In addition, the gratis warranty period for repaired products shall not exceed the gratis warranty period established prior to repair.

Gratis Warranty Range

The gratis warranty range shall be limited to normal use based on the usage conditions, methods and environment, etc., defined by the terms and precautions, etc., given in the instruction manual, user's manual and caution labels on the product.

Warranty Period after Discontinuation of Production

(1) MEE shall offer product repair services (fee applied) for seven (7) years after production of the product has been discontinued. Discontinuation of production shall be reported via distributors.

(2) Product supply (including spare parts) is not possible after production has been discontinued.

Exclusion of Opportunity Loss and Secondary Loss from Warranty Liability

Regardless of the gratis warranty period, MEE shall not be liable for compensation for damages arising from causes not attributable to MEE, opportunity losses or lost profits incurred by the user due to Failures of MEE products, damages or secondary damages arising from special circumstances, whether foreseen or unforeseen by MEE, compensation for accidents, compensation for damages to products other than MEE products, or compensation for other work carried out by the user.

Changes in Product Specifications

The specifications given in the catalogs, manuals and technical documents are subject to change without notice.

This document is a new publication, effective June 2020. Specifications are subject to change without notice.