

Mitsubishi Electric Programmable Controller Renewal Tool

Conversion Adapter

Model
ERNT-ASLTY22



User's Manual

50CM-D180166-D(1612)

MITSUBISHI ELECTRIC ENGINEERING COMPANY LIMITED

HEAD OFFICE: HULLIC KUDAN BLDG. 1-13-5, KUDANKITA CHIYODA-KU, TOKYO 102-0073, JAPAN
NAGOYA ENGINEERING OFFICE: 139 SHIMOHASHIKICHO-SHIMOHASHIKI, KASUGAI, AICHI 486-0906, JAPAN

SAFETY PRECAUTIONS

(Always read these precautions prior to use.)

Before using this product, please read this manual carefully and pay full attention to safety to ensure that the product is used correctly.

The precautions presented in this manual are concerned with this product only. For Programmable Controller system safety precautions, refer to the user's manual of the MELSEC-L series CPU module to be used.

In this manual, the safety precautions are ranked as "WARNING" and "CAUTION."

	Indicates that incorrect handling may cause hazardous conditions, resulting in death or severe injury.
	Indicates that incorrect handling may cause hazardous conditions, resulting in medium or minor injury and/or property damage.

Note that failure to observe the CAUTION level instructions may lead to a serious consequence according to the circumstances. Always follow the precautions of both levels because they are important to personal safety.

Please keep this manual in an easy-to-access location for future reference, and be sure to provide the manual to the end user.

Precautions before using

CAUTION

- When making a switch from the MELSEC-AnS Series to the MELSEC-L Series, be sure to consult user's manual supplied with individual module under the MELSEC-L Series to confirm differences in various aspects including performance, function, CPU input/output signals and buffer memory addresses between the two series.

Installation Precautions

CAUTION

- Use the Conversion Adapter in the environmental conditions that are specified in the general specification. If the Products are used in any environment beyond the bounds of the general specification, electric shock, fire, malfunction, or damage to or degradation of the Products will result.
- Do not directly touch any conductive parts of Conversion Adapter. Contact will cause malfunction or failure in the system.
- Fasten the Conversion Adapter and the Mounting Bracket securely with retaining screws, and tighten the screws by applying torque within specified limits. Loose screws can lead to the dropping of the Conversion Adapter or Mounting Bracket, possibly causing breakage thereof. Excessive tightness of the screws can lead to breakage of the screws, Conversion Adapter, Mounting Bracket, or MELSEC-L Series Module, possibly causing the dropping, shorting, and malfunction thereof.
- Always check for correct match between MELSEC-L Series and the Conversion Adapter. Incorrect match can cause damage to the MELSEC-L Series Module.
- When installing the Conversion Adapter, take care not to get your hand snagged on the Mounting Bracket or the like. Injury may result.
- When installing or removing the MELSEC-L Series Module complete with a Converter Adapter, be sure to hold it with both hands. Dropping may lead to breakage.

Wiring Precautions

WARNING

- Before attempting to install the Unit or carry out the necessary wiring, make certain that the external power supply, used in the system, is shut off on all three phases. Failure to do so may result in electric shock or damage to the product.
- After installation and wiring, close the terminal block cover before turning on the module for operation. Failure to do so may result in electric shock.

Wiring Precautions

CAUTION

- Carry out wiring for the Conversion Adapter correctly after checking the specification and terminal arrangement for the module used. Connecting a power supply with a different voltage rating or incorrect wiring may cause a fire or failure.
- Tighten the MELSEC-AnS Series terminal installation screws and terminal screw securely by applying torque within the specified limits. Loose screws will cause short circuit, fire or malfunction. Excessive tightening will damage the screws or the Conversion Adapter which in turn will cause dropping of parts, short circuit or malfunction.
- Use care to prevent foreign materials including cuttings and wiring debris from entering the Conversion Adapter or the MELSEC-L Series Module. These will be cause for fire, failure or malfunction.

Startup and Maintenance Precautions

WARNING

- Do not touch live terminals. There is a danger of electric shock or malfunction.
- Shut off the external power supply for the system in all phases before cleaning or retightening the terminal screws. Failure to do so may result in electric shock or cause the MELSEC-L Series module to fail or malfunction. Loose screws can lead to dropping, shorting, and malfunction. Excessive tightness of the screws can lead to breakage of the screws, Conversion Adapter, Mounting Bracket, or MELSEC-L Series Module, possibly causing the dropping, shorting, and malfunction thereof.

CAUTION

- Do not modify the Conversion Adapter or take it apart. Doing so will cause failure, malfunction, personal injury, or fire.
- Do not drop the Conversion Adapter and Mounting Bracket or do not give a strong impact to it. This will cause damage.

Disposal Precautions

CAUTION

- When disposing of the product, treat it as industrial waste.

EMC AND LOW VOLTAGE DIRECTIVES

Compliance to the EMC Directive, which is one of the EU Directives, has been a legal obligation for the products sold in European countries since 1996 as well as the Low Voltage Directive since 1997.

Manufacturers who recognize their products are compliant to the EMC and Low Voltage Directives are required to declare that print a "CE mark" on their products.

Authorized representative in Europe

Authorized representative in Europe is shown below.

Name: Mitsubishi Electric Europe B.V.

Address: Mitsubishi-Electric-Platz 1, 40882 Ratingen, Germany

1. Overview

This manual describes specifications, handling and other information about the Conversion Adapter "ERNT-ASLTY22" available as Renewal Tools for the Mitsubishi Electric Programmable Controller. The Conversion Adapter is a product for effecting conversion to transcend difference in pin assignment between the MELSEC-AnS Series and the MELSEC-L Series.

Before attempting to make a switch from MELSEC-AnS Series to MELSEC-L Series in your installation, consult the user's manual supplied with individual module under the latter series to learn about how they differ in various aspects including performance and function.

Once you have opened the packaging, verify that it contains the following products.

Product	Shape	Quantity
Conversion Adapter		1
Mounting bracket		1
Mounting bracket fixing screws (M3.5 x 6)		1
Terminal block cover		1
This manual	—	1

2. General Specifications

Item	Specifications					
Operating ambient temperature	0 to 55°C (Maximum surrounding air temperature 55°C)					
Storage ambient temperature	-25 to 75°C					
Operating ambient humidity	5 to 95%RH, non-condensing					
Storage ambient humidity	5 to 95%RH, non-condensing					
Vibration resistance	Compliant with JIS B 3502 and IEC 61131-2	Under intermittent vibration	5 to 8.4Hz	—	3.5mm	10 times each in X, Y, Z directions
		Under continuous vibration	8.4 to 150Hz	9.8m/s ²	—	
			5 to 8.4Hz	—	1.75mm	
Shock resistance	Compliant with JIS B 3502 and IEC 61131-2 (147 m/s ² , 3 times each in 3 directions X, Y, Z)					
Operating atmosphere	No corrosive gases					
Operating altitude *1	0 to 2000m					
Installation location	Inside a control panel					
Overvoltage category *2	II or less					
Pollution degree *3	2					

*1 : Do not use or store under pressure higher than the atmospheric pressure of altitude 0m.

*2 : This indicates the section of the power supply to which the equipment is assumed to be connected between the public electrical power distribution network and the machinery within premises. Category II applies to equipment for which electrical power is supplied from fixed facilities.

*3 : This index indicates the degree to which conductive material is generated in terms of the environment in which the equipment is used. Pollution level 2 is when only non-conductive pollution occurs. A temporary conductivity caused by condensing must be expected occasionally.

3. Product Specifications

For detail specifications which do not appear in the specification comparison charts contained herein, see the user's manual supplied with the MELSEC-L Series module you use. Those parts of the specification that differ between the MELSEC-AnS Series and the MELSEC-L Series are where a switch from the first series to the second is subjected to specification-related restrictions. Check the specification of the devices to be connected for more details.

Furthermore, it is recommended to refer to the "Transition from MELSEC-AnS/QnAS (Small Type) Series to L Series Handbook (Fundamentals): L (NA)-08258ENG" issued by Mitsubishi Electric.

Conversion Adapter Model	Before replacement MELSEC-AnS Series Module Model	No. of output points	After replacement MELSEC-L Series Module Model	No. of modules	Conversion Adapter Weight (g)
ERNT-ASLTY22	A1SY22	16	LY20S6	1	75

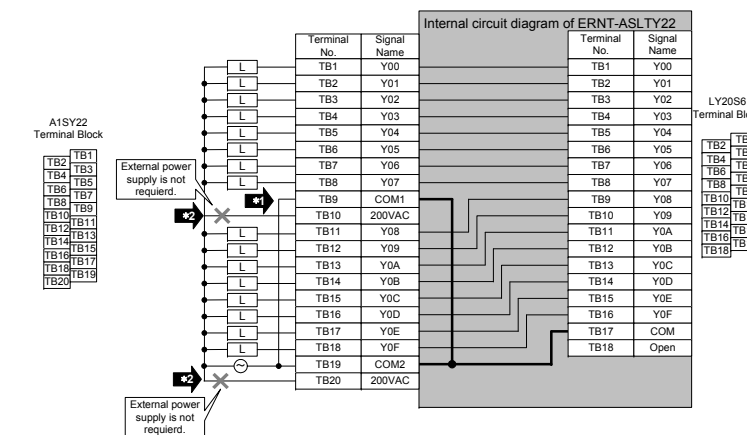

Precautions for wiring

*1 Because the switch concerned causes the number of points per common to change from 8 (two circuits) to 16 (one circuit), an alteration to the wiring is required if the terminal numbers TB9 and TB19 on the MELSEC-AnS-side terminal block have been used in separation from each other.

*2 External power supply (24VDC) connected to the terminal numbers TB10 (200VAC) and TB20 (200VAC) on the MELSEC-AnS-side terminal block becomes unnecessary. However, that leaving the terminals connected will not cause a problem because the wire is not connected inside the Conversion Adapter.

< Specification Comparison >

Specifications	Model	MELSEC-AnS Series	MELSEC-L Series
		A1SY22	LY20S6
No. of output points		16 points	16 points
Isolation method		Photocoupler isolation	Photocoupler isolation
Rated load voltage		100 to 240VAC 50/60Hz±3Hz	100 to 240VAC(+10%/-15%) 50/60Hz±3Hz
Maximum load current		0.6A/point, 2.4A/common	0.6A/point, 4.8A/common
Minimum load voltage /current		24VAC 100mA 100VAC 10mA 240VAC 20mA	24VAC 100mA 100VAC 25mA 240VAC 25mA
Maximum in-rush current		20A 10ms or less, 8A 100ms or less	20A/cycle or less
Leakage current at OFF		1.5mA(120VAC 60Hz) 3mA(240VAC 60Hz)	1.5mA or lower (120VAC 60Hz) 3mA or lower (240VAC 60Hz)
Maximum voltage drop at ON		1.5VAC or lower (0.1 to 0.6A) 1.8VAC or lower (50 to 100mA) 2VAC or lower (10 to 50mA)	1.5V or lower (load current of 0.6A)
Response time	OFF→ON	1ms or less	1ms+0.5cycle or less
	ON→OFF	1ms+0.5cycle or less	1ms+0.5cycle or less (rated load, resistance load)
Surge killer		CR absorber	CR absorber
Fuse		5A (one/common) non-replaceable	None (Attaching a fuse to each external wiring is recommended.) 300 mA
Internal current consumption		270mA (TYP. all points ON)	300 mA (TYP. all points ON)
Wiring method for common		8 points, 1 common	16 points, 1 common
External connection system		20-point terminal block	18-point terminal block

Make sure the section of the above table meets the specification of the machines and equipment connected to the MELSEC-L Series module.

4. Mounting and Installation

4.1 Handling Precautions

- Before attempting to install the Unit or carry out the necessary wiring, make certain that the external power supply, used in the system, is shut off on all three phases. Failure to do so may result in electric shock or damage to the product.
- Do not touch live terminals. There is a danger of electric shock or malfunction.
- Do not modify the Conversion Adapter or take it apart. Doing so will cause failure, malfunction, personal injury, or fire.
- Do not touch the energized part of the Conversion Adaptor directly. Contact will cause malfunction or failure in the system.
- Fasten the Conversion Adapter and the Mounting bracket securely with retaining screws, and tighten the screws by applying torque within specified limits. Loose screws can lead to the dropping of the Conversion Adapter, or Mounting bracket, possibly causing breakage thereof. Excessive tightness of the screws can lead to breakage of the screws, Converter Adaptor, Mounting bracket, or MELSEC-L Series Module, possibly causing the dropping, shorting, and malfunction thereof.
- Use care to prevent foreign materials including cuttings and wiring debris from entering the Conversion Adapter or the MELSEC-L Series Module. These will be cause for fire, failure or malfunction.
- Do not drop the Conversion Adapter and Mounting Bracket or do not give a strong impact to it. This will cause damage.

4.2 Use Precautions

Item	Use Precautions
Width dimension of module	<p>Because the module is reduced in width dimension (34.5mm→28.5mm) and thus in area available for wiring, check dimensional data before installing the module.</p> <p><MELSEC-AnS Series> <MELSEC-L Series></p> <p>34.5mm 28.5mm</p>
	<p>The wiring may interfere with the adjacent module. Use of the Mitsubishi Electric LG69 space module is recommended.</p> <p><MELSEC-AnS Series> <MELSEC-L Series></p> <p>34.5mm 16.5mm 28.5mm</p> <p>45mm</p>
Depth and Height dimension	<p>Installation with the Base Adapter</p> <p>Because the module is increased in depth dimension, check dimensional data before installing the module.</p> <p>MELSEC-AnS MELSEC-L Conversion Adapter Base Adapter</p> <p>110mm 161.3mm</p> <p>51.3mmUP</p> <p>Installation with the DIN rail</p> <p>Because the module is increased in depth and height dimension, check dimensional data before installing the module.</p> <p>MELSEC-AnS MELSEC-L Conversion Adapter</p> <p>4mm 66mm 70.2mm 106mm 144.5mm</p> <p>15.2mmUP 38.5mmUP</p>
Terminal block cover	<p>The terminal block cover for MELSEC-AnS Series is bigger than the width of the MELSEC-L Series Module. Therefore, it is necessary to replace it with the terminal block cover supplied with the converter adapter.</p> <p><MELSEC-AnS Series> <MELSEC-L Series></p> <p>Terminal block cover for the MELSEC-AnS Series Replace the terminal block cover with the one supplied with the Conversion Adapter.</p> <p>34.5mm 28.5mm</p>

4.3 Installation Environment

The installation environment is the same as MELSEC-L series CPU Module to use. Refer to the user's manual of the MELSEC-L Series CPU Module to be used.

5. Part Names and Installation Method

【Installation with the Base Adapter】

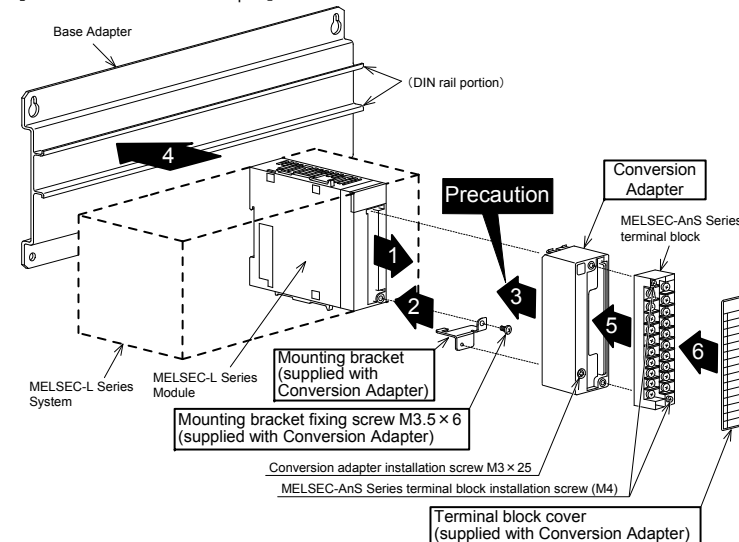

【Installation with the DIN rail】

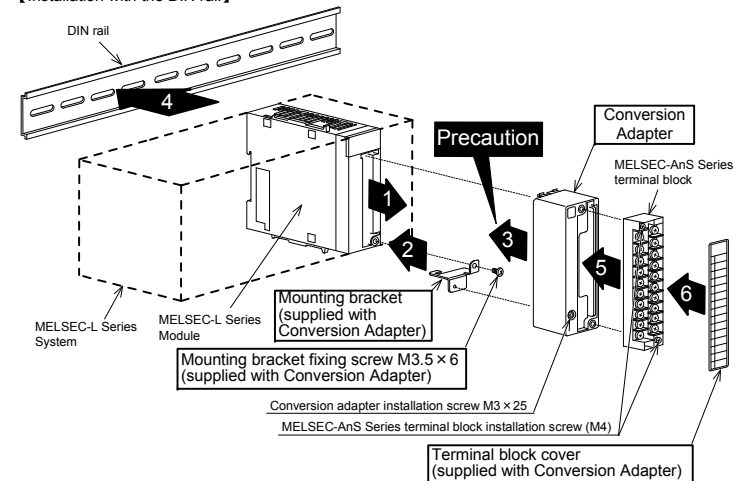

5.1 Installation Method

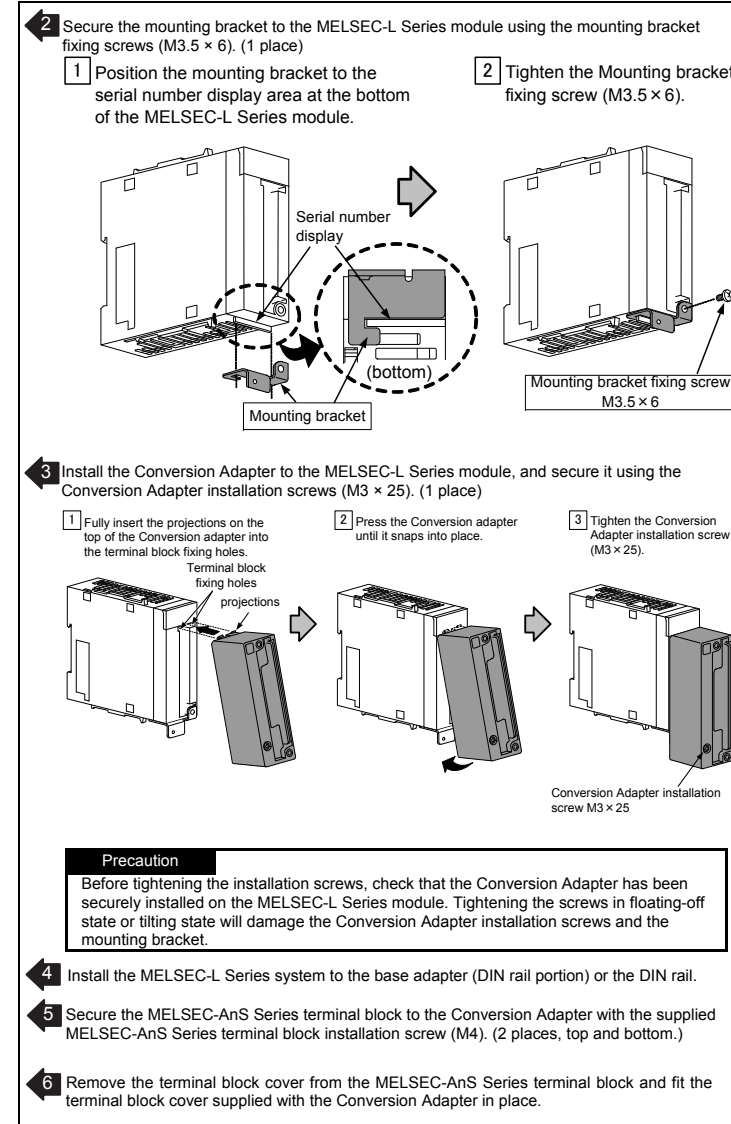
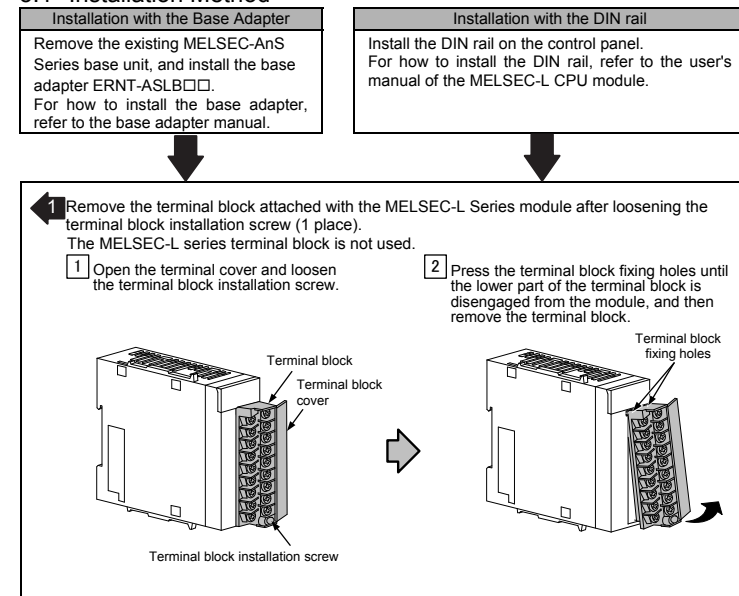

5.2 Tightening Torque

Tighten the installation screws to the specified torque below. An inappropriate tightening torque could cause the product to fall or result in a short circuit, product failure or malfunction.

Screw Location	Tightening Torque Range
Mounting bracket fixing screw (M3.5x6)	0.68 to 0.92N·m
Conversion Adapter installation screw (M3x25)	0.43 to 0.57N·m
MELSEC-AnS Series terminal block installation screw (M4 screw)	0.78 to 1.18N·m

6. External Dimensions

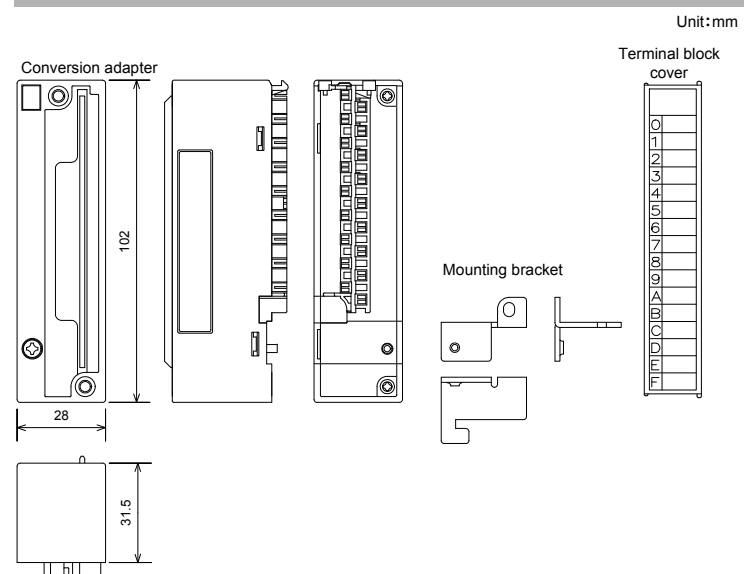

Duplication Prohibited

This manual may not be reproduced in any form, in part or in whole, without written permission from Mitsubishi Electric Engineering Company Limited.
©2014 MITSUBISHI ELECTRIC ENGINEERING COMPANY LIMITED ALL RIGHTS RESERVED

MELSEC is a registered trademark of Mitsubishi Electric Corporation.

Product Warranty Details

Please confirm the following product warranty details prior to product use.

Gratis Warranty Terms and Gratis Warranty Range

If any fault or defect (hereinafter referred to as "Failure") attributable to Mitsubishi Electric Engineering Company Limited (hereinafter referred to as "MEE") should occur within the gratis warranty period, MEE shall repair the product free of charge via the distributor from whom you made your purchase.

Gratis Warranty Period

The gratis warranty period of this product shall be one (1) year from the date of purchase or delivery to the designated place. Note that after manufacture and shipment from MEE, the maximum distribution period shall be six (6) months, and the gratis warranty period after manufacturing shall be limited to eighteen (18) months. In addition, the gratis warranty period for repaired products shall not exceed the gratis warranty period established prior to repair.

Gratis Warranty Range

The gratis warranty range shall be limited to normal use based on the usage conditions, methods and environment, etc., defined by the terms and precautions, etc., given in the instruction manual, user's manual and caution labels on the product.

Warranty Period after Discontinuation of Production

- MEE shall offer product repair services (fee applied) for seven (7) years after production of the product has been discontinued. Discontinuation of production shall be reported via distributors.
- Product supply (including spare parts) is not possible after production has been discontinued.

Exclusion of Opportunity Loss and Secondary Loss from Warranty Liability

Regardless of the gratis warranty period, MEE shall not be liable for compensation for damages arising from causes not attributable to MEE, opportunity losses or lost profits incurred by the user due to Failures of MEE products, damages or secondary damages arising from special circumstances, whether foreseen or unforeseen by MEE, compensation for accidents, compensation for damages to products other than MEE products, or compensation for other work carried out by the user.

Changes in Product Specifications

The specifications given in the catalogs, manuals and technical documents are subject to change without notice.

This document is a new publication, effective December 2016. Specifications are subject to change without notice.

Developed December 2016
50CM-D180166-D