

Mitsubishi General-Purpose Programmable Controller

Renewal Tool

Conversion Adapter DIN Rail Mounting Bracket

Model

ERNT-ASQDIN3355
ERNT-ASQDIN356500J
ERNT-ASQDIN3868

User's Manual



50CM-D180128-B(1604)

MITSUBISHI ELECTRIC ENGINEERING COMPANY LIMITED

HEAD OFFICE: 4-1-3-5, KUDANKITA CHIYODA-KU, TOKYO 102-0073, JAPAN
 NAGOYA ENGINEERING OFFICE: 139 SHIMOYASHIKI-KO, SHIMOYASHIKI, KASUGAI, AICHI 486-0906, JAPAN

SAFETY PRECAUTIONS

(Always read these precautions prior to use.)

Before using this product, please read this manual carefully and pay full attention to safety to ensure that the product is used correctly.

The precautions presented in this manual are concerned with this product only. For Programmable Controller system safety precautions, refer to the user's manual of the MELSEC-Q series CPU module to be used.

In this manual, the safety precautions are ranked as "WARNING" and "CAUTION."



WARNING

Indicates that incorrect handling may cause hazardous conditions, resulting in death or severe injury.

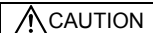

CAUTION

Indicates that incorrect handling may cause hazardous conditions, resulting in medium or minor injury and/or property damage.

Note that failure to observe the CAUTION level instructions may lead to a serious consequence according to the circumstances. Always follow the precautions of both levels because they are important to personal safety.

Please keep this manual in an easy-to-access location for future reference, and be sure to provide the manual to the end user.

[Precautions: Prior to use]

CAUTION

- When making a switch from the MELSEC-AnS Series to the MELSEC-Q Series, be sure to consult user's manual supplied with individual module under the MELSEC-Q Series to confirm differences in various aspects including performance and function between the two series.

[Installation Precautions]

WARNING

- Before attempting to install the Unit, make certain that the external power supply, used in the system, is shut off on all three phases. Failure to do so may result in electric shock or damage to the product.

CAUTION

- Use the Conversion Adapter DIN Rail Mounting Bracket in the environmental conditions that are specified in the general specification contained in the user's manual supplied with the MELSEC-Q Series CPU Module. If the Products are used in any environment beyond the bounds of the general specification, electric shock, fire, malfunction, or damage to or degradation of the Products will result.
- Fasten the Conversion Adapter DIN Rail Mounting Bracket and the MELSEC-Q Series Base Unit securely with retaining screws, and tighten the screws by applying torque within specified limits. Loose screws can lead to the dropping of the Conversion Adapter DIN Rail Mounting Bracket or MELSEC-Q Series Base Unit, possibly causing breakage thereof. Excessive tightness of the screws can lead to breakage of the screws, Conversion Adapter DIN Rail Mounting Bracket or MELSEC-Q Series Base Unit, possibly causing the dropping, shorting, and malfunction thereof.

[Startup and Maintenance Precautions]

WARNING

- Shut off the external power supply for the system in all phases before cleaning or retightening the terminal screws. Failure to do so may result in electric shock. Loose screws can lead to dropping, shorting, and malfunction. Excessive tightness of the screws can lead to breakage of the screws, Conversion Adapter DIN Rail Mounting Bracket, or MELSEC-Q Series Module, possibly causing the dropping, shorting, and malfunction thereof.

CAUTION

- Do not drop the Conversion Adapter DIN Rail Mounting Bracket or do not give a strong impact to it. This will cause damage.

[Disposal Precautions]

CAUTION

- When disposing of the product, treat it as industrial waste.

安全注意事项

(使用前请务必阅读)

使用本产品时, 请仔细阅读本手册, 并充分注意安全, 正确地使用产品。本手册中标注的注意事项仅记载了与本产品相关的内容。关于可编程控制器系统的安全注意事项, 请参阅所使用的MELSEC-Q系列CPU模块的用户手册。在本安全注意事项中, 安全注意事项的等级分为「警告」和「注意」。



警告

表示错误操作可能造成危险后果, 引起死亡或重伤事故。



注意

表示错误操作可能造成危险后果, 引起中度伤害、轻伤及财产损失。

另外, 根据情况不同, 即使是注意中记载的事项, 也可能引发严重后果。不管哪个记载的都是非常重要的内容, 请务必遵守。

请妥善保管本手册, 以便需要时取阅, 并将本手册交给最终用户。

[使用前的注意事项]

注意

- 从MELSEC-AnS系列替换至MELSEC-Q系列时, 为确认性能和功能等方面的差异, 请务必参照MELSEC-Q系列的各模块的手册进行使用。

[安装注意事项]

警告

- 请务必切断系统使用的所有相的外部供电电源后再进行安装。如果不切断所有相的电源, 可能会触电或造成产品损坏。

注意

- 应在MELSEC-Q系列CPU模块用户手册中记载的一般规格环境下使用转换适配器DIN导轨安装配件。如果在一般规格范围以外的环境中使用转换适配器DIN导轨安装配件, 可能导致触电、火灾、误动作、产品损坏或性能劣化。
- 转换适配器DIN导轨安装配件及MELSEC-Q系列基板应通过安装螺钉切实加以固定, 安装螺钉应在规定的扭矩范围内切实地拧紧。如果螺钉拧得过松, 有可能因掉落而导致转换适配器DIN导轨安装配件及MELSEC-Q系列基板破损。如果螺钉拧得过紧, 有可能导致螺钉、转换适配器DIN导轨安装配件及MELSEC-Q系列基板破损, 从而导致掉落。

[启动和维护注意事项]

警告

- 在清洁模块或重新紧固安装螺钉时, 必须将系统使用的外部供电电源全部断开后再进行操作。如果未全部断开, 有可能导致触电。如果螺钉拧得过松, 有可能导致掉落、短路或误动作。如果螺钉拧得过紧, 有可能导致螺钉、转换适配器DIN导轨安装配件及MELSEC-Q系列基板破损, 从而导致掉落、短路或误动作。

注意

- 请勿使转换适配器DIN导轨安装配件掉落或受到强烈撞击。否则可能导致破损。

[废弃注意事项]

注意

- 废弃时请将本产品作为工业废弃物处理。

1. Overview

This manual provides information about the Conversion Adapter DIN Rail Mounting Bracket "ERNT-ASQDIN3355, ERNT-ASQDIN356500J, ERNT-ASQDIN3868" available as Renewal Tools for the Mitsubishi General-Purpose Programmable Controller.

A Conversion Adapter DIN rail mounting bracket is required to secure a Conversion Adapter with a fixture (see the table below) when a MELSEC-Q Series Base Unit is mounted to a DIN rail.

	Conversion Adapter with a fixture
For Analog input	ERNT-ASQT68AD-G
For Temperature input	ERNT-ASQT68TD-H01, ERNT-ASQT68TD-H02
For High-Speed Counter	ERNT-ASQTD61, ERNT-ASQTD62, ERNT-ASQTD62D

Before attempting to make a switch from MELSEC-AnS Series to MELSEC-Q Series in your installation, consult the user's manual supplied with individual module under the latter series to learn about how they differ in various aspects including performance and function.

Once you have opened the packaging, verify that it contains the following products.

Product	Shape	Quantity
Conversion Adapter DIN Rail Mounting Bracket (right)		1
Conversion Adapter DIN Rail Mounting Bracket (bottom)		1
Stopper		1
Installation screws (M4 x 8)		4

2. Product Specifications

Conversion Adapter DIN Rail Mounting Bracket Model	Specifications	
	Compatible MELSEC-Q Series Base Unit Model	Weight (g)
ERNT-ASQDIN3355	Q33B, Q55B	150
ERNT-ASQDIN356500J	Q35B, Q65B, Q00JCPU, Q00UJCPU	165
ERNT-ASQDIN3868	Q38B, Q68B	195

A separately-sold DIN rail mounting adapter that is manufactured by Mitsubishi Electric is required to mount a MELSEC-Q Series Base Unit to a DIN rail.

MELSEC-Q Series Base Unit Model	DIN rail mounting adapter type
Q38B, Q68B	Q6DIN1
Q35B, Q65B, Q00JCPU, Q00UJCPU	Q6DIN2
Q33B, Q55B	Q6DIN3

3. Mounting and Installation

3.1 Handling Precautions

- Before attempting to install the Unit, make certain that the external power supply, used in the system, is shut off on all three phases. Failure to do so may result in electric shock or damage to the product.
- Fasten the Conversion Adapter DIN Rail Mounting Bracket and the MELSEC-Q Series Base Unit securely with retaining screws, and tighten the screws by applying torque within specified limits. Loose screws can lead to the dropping of the Conversion Adapter DIN Rail Mounting Bracket or MELSEC-Q Series Base Unit, possibly causing breakage thereof. Excessive tightness of the screws can lead to breakage of the screws, Conversion Adapter DIN Rail Mounting Bracket or MELSEC-Q Series Base Unit, possibly causing the dropping.
- Do not drop the Conversion Adapter DIN Rail Mounting Bracket or do not give a strong impact to it. This will cause damage.

3.2 Installation Environment

For details of the installation environment, refer to the user's manual of the MELSEC-Q Series CPU Module to be used.

4. Installation Dimensions

- MELSEC-Q Series modules are 4mm bigger on the downside than MELSEC-AnS Series modules.
- Adjust the wiring length when replacing the MELSEC-AnS series with the MELSEC-Q series because their module-mounting slot positions are different.

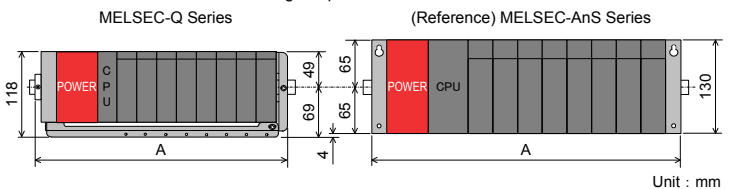

MELSEC-Q Series Base Unit Model	A	MELSEC-AnS Series Base Unit Model	A
Q33B	213	A1S33B	255
Q35B	268.5	A1S35B	325
Q38B	352	A1S38B, A1S38HB	430
Q55B	211	A1S55B	260
Q65B	266.5	A1S65B	315
Q68B	350	A1S68B	420
Q00JCPU, Q00UJCPU	268.4	A1SJCPU, A1SJCPU-S3, A1SJHCPU	330

5. Part Names and Installation Method

5.1 Installation Method

The installation can be performed according to any of the following procedures.

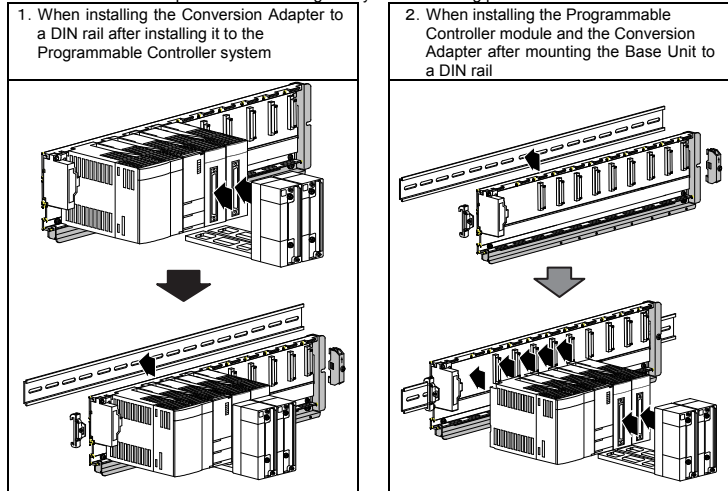

Mount a separately-sold DIN rail mounting adapter (large and small) manufactured by Mitsubishi Electric to the rear side of the MELSEC-Q Series Base Unit. Refer to the "QCPU User's Manual (Hardware Design, Maintenance and Inspection)" issued by Mitsubishi Electric for installation methods.

DIN rail mounting adaptors	Components				
	Adaptor (Large)	Adaptor (small)	Square washer	Mounting screw (M5x10)	Stopper
Q6DIN1, Q6DIN2, Q6DIN3	Mounted to the rear side of the Base Unit	Used to be installed to a DIN rail	Used to be installed to a DIN rail	Mounted to the left side of the Base Unit (*1)	

*1: Only one will be used.

- Install the MELSEC-Q Series Base Unit to the DIN rail.
- Mount the fixing bracket of the DIN rail mounting adapter manufactured by Mitsubishi Electric to the left side of the MELSEC-Q Series Base Unit.

Refer to the "QCPU User's Manual (Hardware Design, Maintenance and Inspection)" issued by Mitsubishi Electric for installation methods.

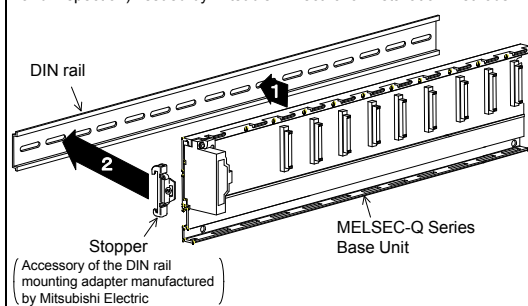

Mount the Conversion Adapter DIN rail mounting bracket (right) to the right side of the MELSEC-Q Series Base Unit.

- Align the Conversion Adapter DIN rail mounting bracket (right) with the fixing holes of the MELSEC-Q Series Base Unit.
- Secure them using the installation screws (M4 x 8).

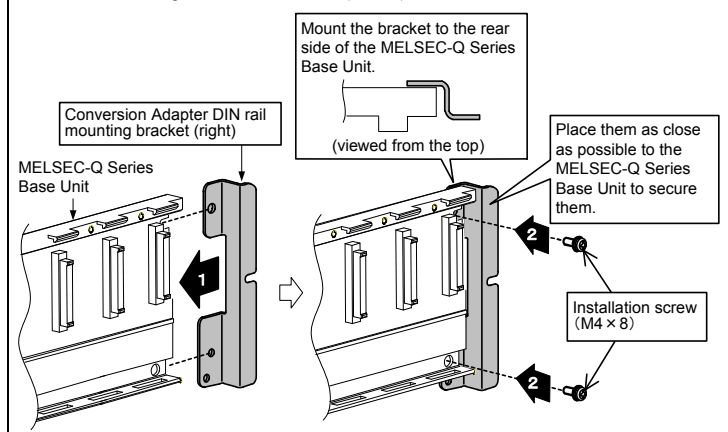

(to the rear side)

(to the rear side)

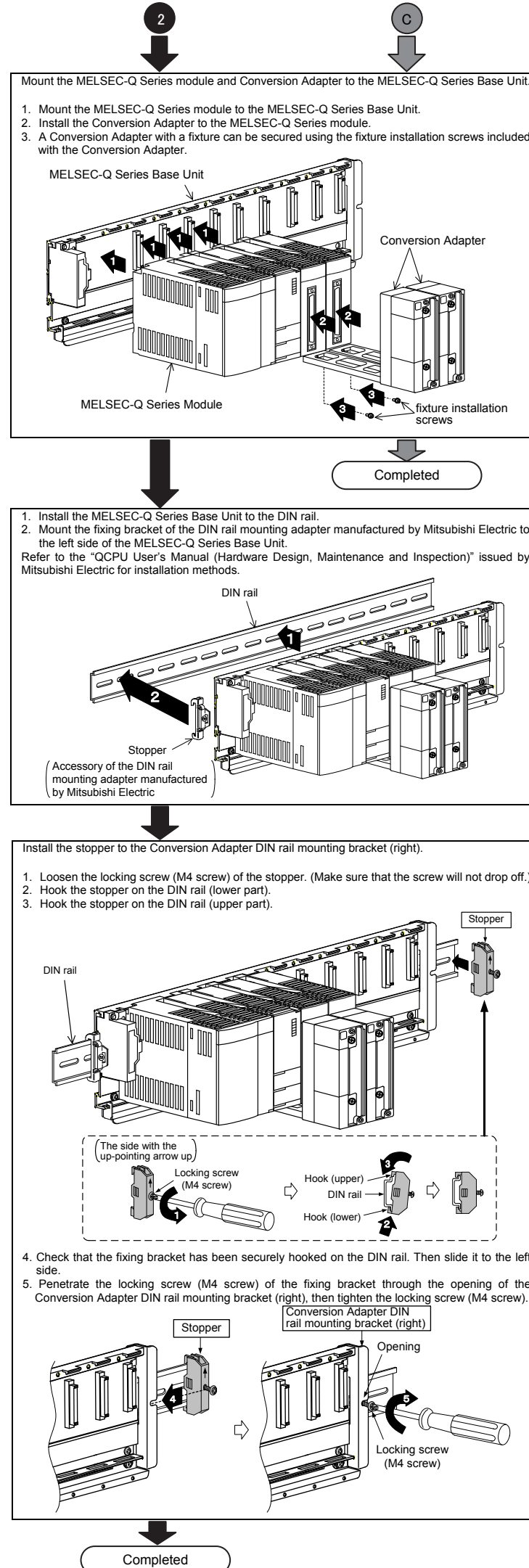
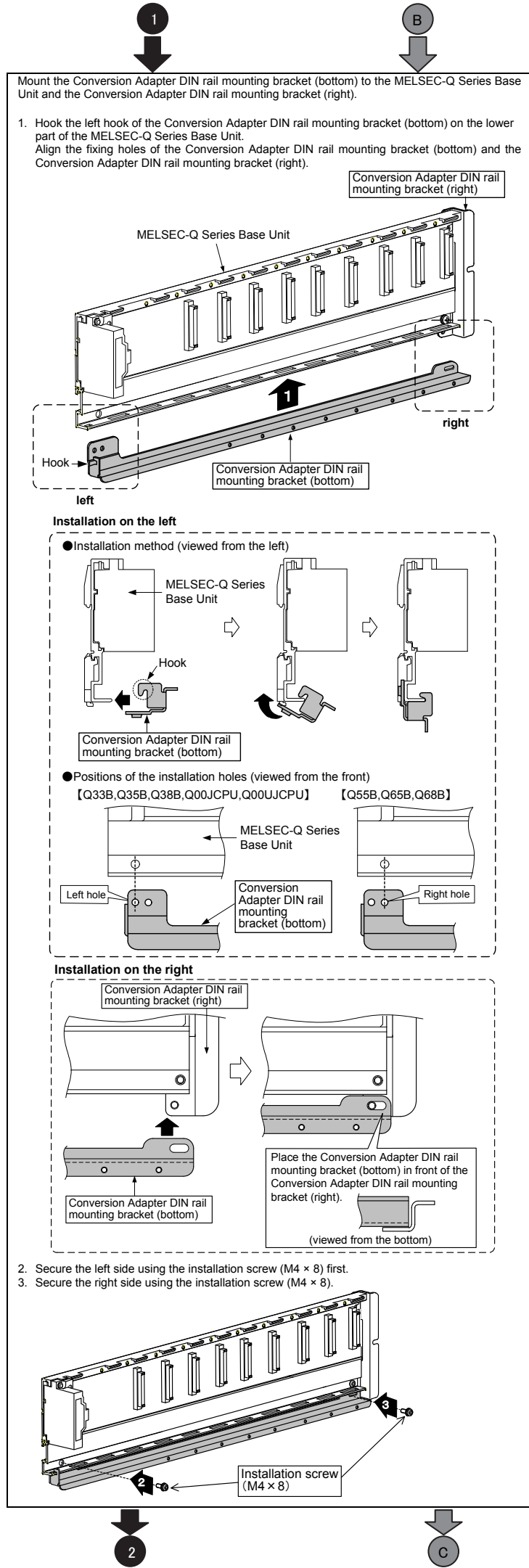
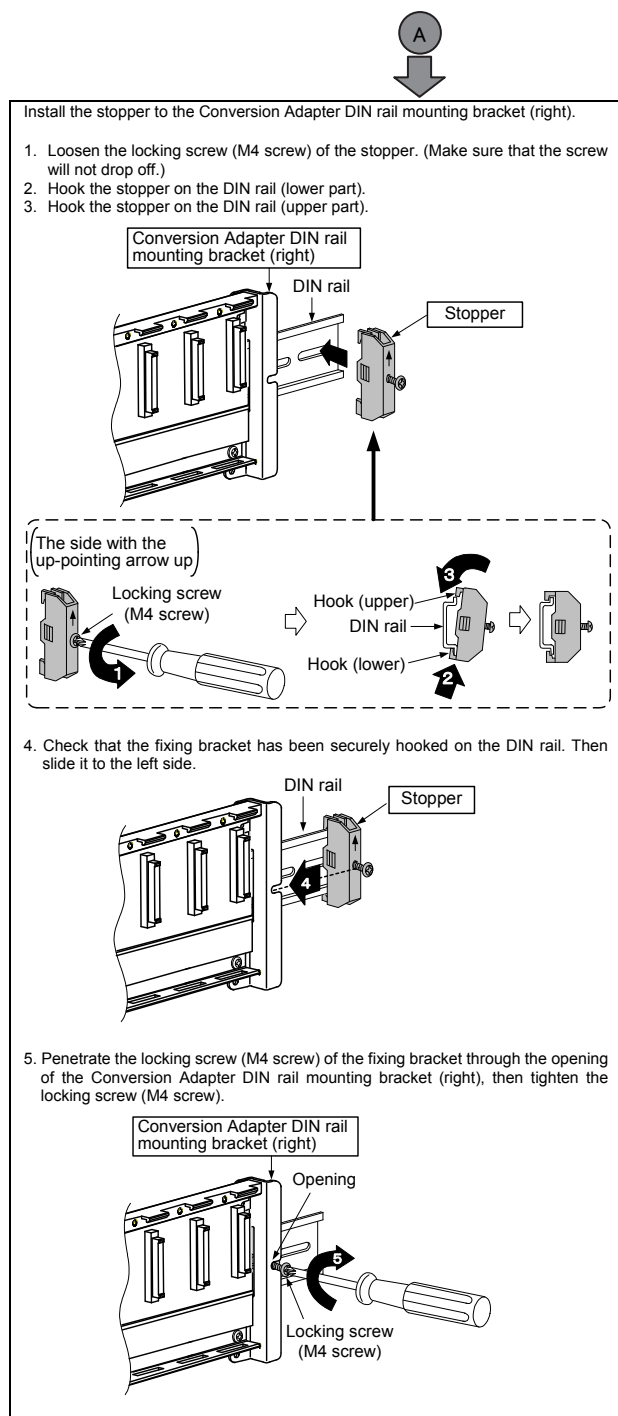

5.2 Tightening Torque

Tighten the installation screws to the specified torque below. An inappropriate tightening torque could cause the product to fall or result in a short circuit, product failure or malfunction.

Screw Location	Tightening Torque Range
Installation screw (M4×8)	1.39 to 1.89 N·m
Locking screw (M4)	

6. External Dimensions

(1) Conversion Adapter DIN rail mounting bracket (right)

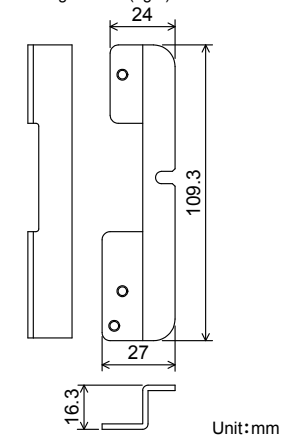

(2) Conversion Adapter DIN rail mounting bracket (bottom)

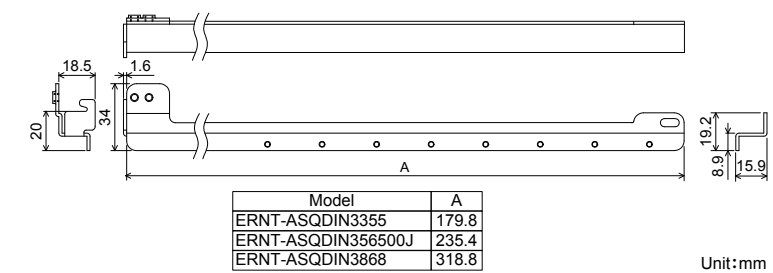

Product Warranty Details

Please confirm the following product warranty details prior to product use.

Gratis Warranty Terms and Gratis Warranty Range

If any fault or defect (hereinafter referred to as "Failure") attributable to Mitsubishi Electric Engineering Company Limited (hereinafter referred to as "MEE") should occur within the gratis warranty period, MEE shall repair the product free of charge via the distributor from whom you made your purchase.

Gratis Warranty Period

The gratis warranty period of this product shall be one (1) year from the date of purchase or delivery to the designated place.

Note that after manufacture and shipment from MEE, the maximum distribution period shall be six (6) months, and the gratis warranty period after manufacturing shall be limited to eighteen (18) months. In addition, the gratis warranty period for repaired products shall not exceed the gratis warranty period established prior to repair.

Gratis Warranty Range

The gratis warranty range shall be limited to normal use based on the usage conditions, methods and environment, etc., defined by the terms and precautions, etc., given in the instruction manual, user's manual and caution labels on the product.

Warranty Period after Discontinuation of Production

- MEE shall offer product repair services (fee applied) for seven (7) years after production of the product has been discontinued. Discontinuation of production shall be reported via distributors.
- Product supply (including spare parts) is not possible after production has been discontinued.

Exclusion of Opportunity Loss and Secondary Loss from Warranty Liability

Regardless of the gratis warranty period, MEE shall not be liable for compensation for damages arising from causes not attributable to MEE, opportunity losses or lost profits incurred by the user due to Failures of MEE products, damages or secondary damages arising from special circumstances, whether foreseen or unforeseen by MEE, compensation for accidents, compensation for damages to products other than MEE products, or compensation for other work carried out by the user.

Changes in Product Specifications

The specifications given in the catalogs, manuals and technical documents are subject to change without notice.

This document is a new publication, effective April 2016. Specifications are subject to change without notice.