

Mitsubishi **General-Purpose** Programmable Controller
Renewal Tool Conversion Adapter

Model

ERNT-AQT616AD

User's Manual



ERNT-AQT616AD

Model	ERNT-AQT616AD
	50CM-D180034-E(1604)

MITSUBISHI ELECTRIC ENGINEERING COMPANY LIMITED

HEAD OFFICE: 5-1-13 S. KUDANJIMA CHYUO-KU, TOKYO 102-8573, JAPAN
NAGOYA ENGINEERING OFFICE: 139 SHIMOYASHIKI-CHO SHIMOYASHIKI, KASUGAI, AICHI 486-0906, JAPAN

A-2

[Wiring Precautions]

⚠ WARNING	
<ul style="list-style-type: none"> Be sure to shut off all phases of the external power supply before performing installation or wiring work. Failure to do so could result in electric shock or product damage. If you want to energize and run the unit after completing the installation and wiring work, be sure to close the terminal block cover attached to the MELSEC-A series terminal block. Failure to do so could result in electric shock. 	

⚠ CAUTION	
<ul style="list-style-type: none"> Properly wire the conversion adapter after verifying the specifications and terminal layout of the module to be used. Connecting a power supply with a different rating or improper wiring could lead to fire or product failure. Securely tighten the conversion adapter installation screws, conversion adapter anchor base installation screws and MELSEC-A series terminal block installation screws within the specified torque range. A loose screw may result in a short circuit, fire or malfunction. An excessively tightened screw may result in screw or conversion adapter damage, causing the conversion adapter to fall, a short circuit or product malfunction. Do not allow foreign matter such as cuttings or wiring shavings to enter the conversion adapter or module. Doing so could lead to fire, failure or malfunction. 	

[Startup and Maintenance Precautions]

⚠ WARNING	
<ul style="list-style-type: none"> Do not touch the terminals during energization. Doing so could result in electric shock or malfunction. Be sure to shut off all phases of the external power supply before cleaning and retightening terminal screws. Failure to do so results in the risk of electric shock. Excessively tightened screws could result in conversion adapter and module damage, causing the conversion adapter to fall, a short circuit, or product malfunction. 	

⚠ CAUTION	
<ul style="list-style-type: none"> Do not disassemble or modify the conversion adapter. Doing so could lead to failure, malfunction, injury or fire. The conversion adapter case is made of resin. Do not drop or apply excessive impact to the case. Doing so could lead to conversion adapter damage. 	

[Disposal Precautions]

⚠ CAUTION	
<ul style="list-style-type: none"> When disposing of the product, treat it as industrial waste. 	

● SAFETY PRECAUTIONS ●

(Always read these precautions prior to use.)

Before using this product, please read this manual carefully and pay full attention to safety to ensure that the product is used correctly.

The precautions presented in this manual are concerned with this product only. For Programmable Controller system safety precautions, refer to the user's manual of the MELSEC-Q series CPU module to be used.

In this manual, the safety precautions are ranked as "WARNING" and "CAUTION".

⚠ WARNING	Indicates that incorrect handling may cause hazardous conditions, resulting in death or severe injury.
⚠ CAUTION	Indicates that incorrect handling may cause hazardous conditions, resulting in medium or minor injury and/or property damage.

Note that failure to observe the ⚠ CAUTION level instructions may lead to a serious consequence according to the circumstances. Always follow the precautions of both levels because they are important to personal safety.

Please keep this manual in an easy-to-access location for future reference, and be sure to provide the manual to the end user.

[Precautions: Prior to Use]

⚠ CAUTION	
<ul style="list-style-type: none"> When replacing the MELSEC-A series with the MELSEC-Q series, be sure to refer to the various MELSEC-Q series module manuals to check the differences in performance, functionality, CPU input/output signals, buffer memory addresses, and the like. In addition, we recommend that you also refer to the document L(NA)08045-D, "Guidelines: Replacing MELSEC-A/QnA (Large-Size) Series with Q Series (Intelligent Function Module)." 	

[Installation Precautions]

⚠ CAUTION	
<ul style="list-style-type: none"> Use the conversion adapter and conversion adapter anchor base in an environment of the general specifications defined in the MELSEC-Q series CPU module user's manual. Failure to do so could lead to electric shock, fire, malfunction or product failure or deterioration. Do not come in direct contact with the conductive area of the conversion adapter. Doing so could lead to system malfunction or failure. Fully secure the conversion adapter and conversion adapter anchor base using the installation screws, and tighten the installation screws securely within the specified torque range. Failure to do so could cause the conversion adapter and anchor base to fall, resulting in conversion adapter and conversion adapter anchor base damage. Be sure to confirm that the MELSEC-Q series and conversion adapter combination is correct. Use of a different combination may result in module damage. 	

A-1

【安装注意事项】

⚠ 注意	
<ul style="list-style-type: none"> 应在MELSEC-Q系列CPU模块用户手册中记载的一般规格环境下使用转换适配器及转换适配器固定台。如果在一般规格范围以外的环境中使用,可能导致触电、火灾、误动作、产品的损坏或劣化。 请不要直接触摸转换适配器的导电部分。否则可能会造成系统误动作、故障。 转换适配器及转换适配器固定台应通过安装螺栓切实地加以固定, 安装螺栓应在规定的扭矩范围内切实地拧紧。可能因掉落而导致转换适配器及转换适配器固定台破损。 请务必确认MELSEC-Q系列模块和转换适配器的组合是否正确。在错误组合下使用时,可能会导致MELSEC-Q系列模块损坏。 	

【接线注意事项】

⚠ 警告	
<ul style="list-style-type: none"> 必须将外部供应全相断开后再进行安装作业等。如果未全相断开,可能会导致触电或产品损坏。 安装、配线作业完成之后进行通电、运行时,必须关闭MELSEC-A系列端子排的端子排盖板。如果未关闭端子排盖板,可能会导致触电。 	

⚠ 注意	
<ul style="list-style-type: none"> 请确认所使用模块的规格及端子排列后正确地进行转换适配器的接线。连接不符合额定值的电源或误配线,会导致火灾或故障。 	

A-4

● 安全注意事项 ●

(使用前请务必阅读)

使用本产品时,请仔细阅读本手册,并充分注意安全,正确地使用产品。

本手册中标注的注意事项仅记载了与本产品相关的内容。关于可编程控制器系统的安全注意事项,请参阅所使用的MELSEC-Q系列CPU模块的用户手册。

在本●安全注意事项●中,安全注意事项的等级分为「警告」和「注意」。

⚠警告	表示错误操作可能造成危险后果,引起死亡或重伤事故。
⚠注意	表示错误操作可能造成危险后果,引起中度伤害、轻伤及财产损失。

另外,根据情况不同,即使是⚠注意中记载的事项,也可能引发严重后果。不管哪个记载的都是非常重要的内容,请务必遵守。

请妥善保管本手册,以便需要时取阅,并将本手册交给最终用户。

【使用前的注意事项】

⚠ 注意	
<ul style="list-style-type: none"> 从MELSEC-A系列替换至MELSEC-Q系列时,为确认性能、功能、CPU对应的输入输出信号、缓冲存储器地址等方面的差异,请务必参照MELSEC-Q系列的各模块的手册进行使用。 	

A-3

REVISIONS

*The manual number is given on the bottom right of the front cover.

Print Date	*Manual Number	Revision
October 2008	50CM-D180034-A	First Edition
April 2010	50CM-D180034-B	Partially corrected EMC AND LOW VOLTAGE DIRECTIVES
July 2010	50CM-D180034-C	Partially corrected SAFETY PRECAUTIONS
July 2014	50CM-D180034-D	Partially corrected EMC AND LOW VOLTAGE DIRECTIVES, Chapter 5, Section 5.1 Delete Chapter 6
April 2016	50CM-D180034-E	Partially corrected EMC AND LOW VOLTAGE DIRECTIVES, Chapter 2

This manual confers no industrial property rights or any rights of any other kind, nor does it confer any patent licenses. Mitsubishi Electric Engineering cannot be held responsible for any problems involving industrial property rights which may occur as a result of using the contents noted in this manual.

EMC AND LOW VOLTAGE DIRECTIVES

Compliance to the EMC Directive, which is one of the EU Directives, has been a legal obligation for the products sold in European countries since 1996 as well as the Low Voltage Directive since 1997. Manufacturers who recognize their products are compliant to the EMC and Low Voltage Directives are required to declare that print a "CE mark" on their products.

Authorized representative in Europe

Authorized representative in Europe is shown below.
Name: Mitsubishi Electric Europe BV
Address: Mitsubishi-Electric-Platz 1, 40882 Ratingen, Germany

A-6

CONTENTS

SAFETY PRECAUTION	A-1
REVISIONS	A-6
EMC AND LOW VOLTAGE DIRECTIVES	A-6
CONTENTS	1
1. Overview	1
2. Conversion Adapter Product Specifications	2
3. Products Required by the Conversion Adapter	5
4. Mounting and Installation	6
5. Part Names and Installation Method	7
6. External Dimensions	8

1. Overview

This manual describes the Mitsubishi general-purpose Programmable Controller renewal tool conversion adapter (ERNT-AQT616AD). The conversion adapter is a product that converts the differences in MELSEC-A series and MELSEC-Q series pin assignments.

When replacing the MELSEC-A series with the MELSEC-Q series, be sure to refer to the various MELSEC-Q series module manuals to check the differences in performance, functionality, CPU input/output signals, buffer memory addresses, and the like. In addition, we recommend that you also refer to the document L(NA)08045-D, "Guidelines: Replacing MELSEC-A/QnA (Large-Size) Series with Q Series (Intelligent Function Module)."

Once you have opened the packaging, verify that it contains the following products.

Product	Quantity
Conversion adapter	1
Mounting bracket	1
Mounting bracket fixing screw (M3.5 x 6)	4

A-5

【废弃注意事项】

⚠ 注意	
<ul style="list-style-type: none"> 废弃时请将本产品作为工业废弃物处理。 	

1

2. Conversion Adapter Product Specifications

Conversion Adapter Model	A Series Module Model	No. of analog input Points	Q Series Module Model	Conversion Adapter Weight (g)
ERNT-AQT616AD	A616AD	16	Q68ADV x 2 Q68ADI x 2	250

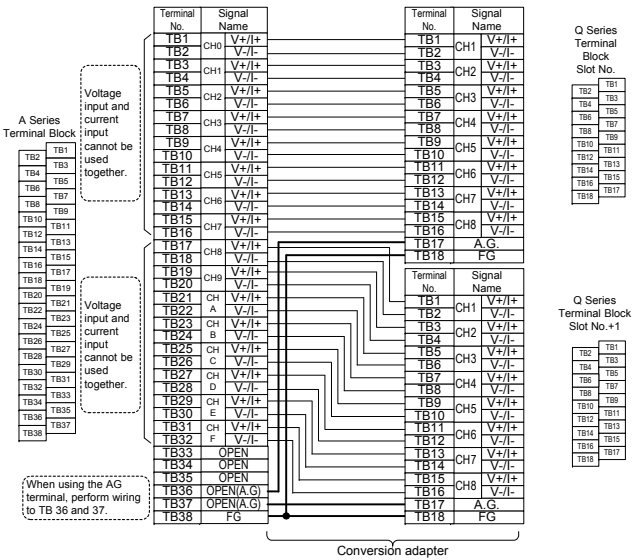

Note:

- When you want to ground the AG terminal (terminal number TB17) of the MELSEC-Q series side, perform grounding using the terminal numbers TB36 and TB37 of the MELSEC-A series side.

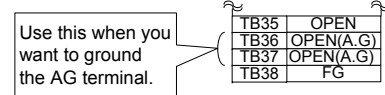

- With Q68ADV/I analog input, voltage and current inputs cannot be used together in a single module. When CH0 to CH7 and CH8 to CHF of the MELSEC-A series side are used with the voltage and current inputs used together, this product cannot be used.
- For A616AD, the Q68ADV/I conversion speed is slower. As a result, the possibility exists that noise that did not occur with A616AD may occur with Q68ADV/I as an analog signal. In such a case, remove the noise using the average processing function.
- Program changes (changes to the number of occupied input/output signals, and buffer memory addresses) are required.
- For detailed and general specifications not stated in the Specification Comparison Chart, refer to the user's manual of the module used. In addition, we recommend that you also refer to the document L(NA)08045-D, "Guidelines: Replacing MELSEC-A/QnA (Large-Size) Series with Q Series (Intelligent Function Module)." For those sections in which the MELSEC-A series specifications and MELSEC-Q series specification differ, specification restrictions may apply upon replacement. Check the specifications of the connected devices.

4. Mounting and Installation

4.1 Handling Precautions

- Do not touch the terminals during energization. Doing so could result in electric shock or malfunction.
- Do not disassemble or modify the conversion adapter. Doing so could result in failure, malfunction, injury or fire.
- Do not come in direct contact with the conductive area of the conversion adapter. Doing so could result in system malfunction or failure.
- Fully secure the conversion adapter and conversion adapter anchor base using the installation screws, and securely tighten the screws within the specified torque range. Failure to do so could cause the conversion adapter and anchor base to fall, resulting in conversion adapter and conversion adapter anchor base damage.

4.2 Use Precautions

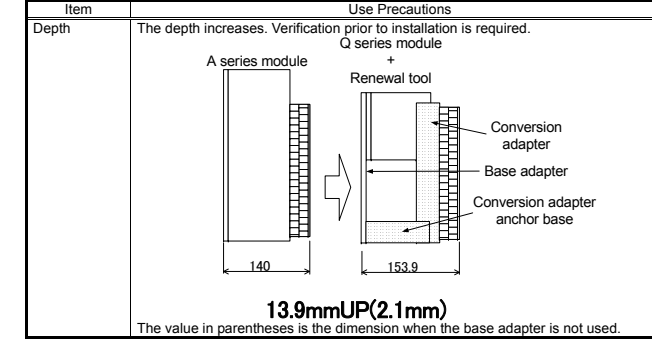

4.3 Installation Environment

For details of the installation environment, refer to the user's manual of the MELSEC-Q series CPU module to be used.

5.2 Tightening Torque

Tighten the module installation screws to the specified torque below. An inappropriate tightening torque could cause the product to fall or result in a short circuit, product failure or malfunction.

Screw Location	Tightening Torque Range
Conversion adapter anchor base installation screw (M4 screw)	139 to 189N·cm
Mounting bracket fixing screw (M3.5 screw)	68 to 92 N·cm
Conversion adapter bottom installation screw (M3 screw)	43 to 57 N·cm
Conversion adapter installation screw (M3 screw)	
MELSEC-A series terminal block installation screw (M4 screw)	102 to 138 N·cm

6. External Dimensions

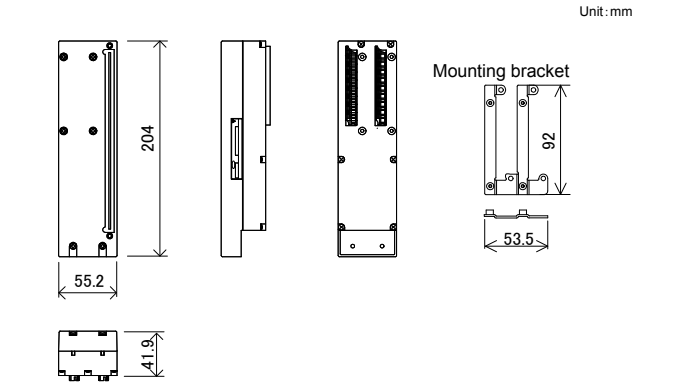

Duplication Prohibited

This manual may not be reproduced in any form, in part or in whole, without written permission from Mitsubishi Electric Engineering Company Limited.

©2014 MITSUBISHI ELECTRIC ENGINEERING COMPANY LIMITED ALL RIGHTS RESERVED

MELSEC is a registered trademark of Mitsubishi Electric Corporation.

Module Specification Comparison Chart

Item	A616AD	Q68ADV	Q68ADI
Analog Input	-10 to 0 to 10VDC (input resistance: 1MΩ)	-10 to 10VDC (input resistance: 1MΩ)	-
Current	-20mA to 0 to 20mA DC (input resistance: 250Ω)	-	0 to 20mA DC (input resistance: 250Ω)
Digital output	16-bit (data section: 12-bit) signed binary (-4096 to 4097, -2048 to 2047) Configurable per channel	16-bit signed binary (Normal resolution mode: -4096 to 4095, High resolution mode: -12288 to 12287, -16384 to 16383)	-
Input/Output characteristics	Input	Normal Resolution Mode	High Resolution Mode
	Output	Normal Resolution Mode	High Resolution Mode
Overall accuracy	0 to 10V, -10V to 10V, 0V to 5V, -20mA to 20mA	±0.3% (digital output value ±1%)	±0.3% (digital output value ±1%)
	0 to 5V, 1 to 5V, 0 to 20mA, -4 to 20mA	±0.4% (digital output value ±2%)	±0.4% (digital output value ±2%)
Maximum conversion speed	1ms/channel	80µs/channel (With temperature drift correction, 160µs is added regardless of the number of channels used.)	-
Absolute maximum	Voltage: ±15V Current: ±30mA	Voltage: ±15V Current: ±30mA	-
No. of analog input points	16 channels/module	8 channels/module	-
Isolation method	Between input terminal and PLC power supply: Photocoupler isolation Between channels: Non-isolated	Photocoupler isolation	Non-isolated
No. of occupied points	32 points	16 points	-
Connected terminal block	38-point terminal block	18-point terminal block	-
Current consumption	1A	0.64A	-

3. Products Required by the Conversion Adapter

(1) Conversion Adapter Anchor Base (Sold Separately)

The conversion adapter anchor base secures the bottom of the conversion adapter and is required for conversion adapter use. One anchor base is required per base.

Conversion Adapter Anchor Base Model	Specifications		
	Type	Weight (g)	
ERNT-AQF12	12-slot conversion adapter anchor base	590	
ERNT-AQF8	8-slot conversion adapter anchor base	410	
ERNT-AQF5	5-slot conversion adapter anchor base	275	
ERNT-AQF3	3-slot conversion adapter anchor base	185	

(2) Base Adapter (Sold Separately)

The base adapter enables MELSEC-Q series installation using the installation holes of the MELSEC-A series base unit. (Additional hole machining not required)

Base Adapter Model	Specifications			Weight (g)
	MELSEC-A Series Compliant Module	MELSEC-Q Series Compliant Module	Installable Conversion Adapter Anchor Base	
ERNT-AQB38	A38B A38B-UL A38B-E A38B A38HBEU	Q312B Q38B	ERNT-AQF12	970
ERNT-AQB68	A68B	Q612B Q68B		930
ERNT-AQB58	A58B A58B-UL	Q68B	ERNT-AQF8	870
ERNT-AQB35	A35B A35B-UL A35B-E	Q38B Q35B	ERNT-AQF8 ERNT-AQF5	795
ERNT-AQB65	A65B A65B-UL	Q68B Q65B Q55B		790
ERNT-AQB55	A55B A55B-UL	Q65B Q55B	ERNT-AQF5	655
ERNT-AQB32	A32B A32B-UL A32B-E	Q33B	ERNT-AQF3	675
ERNT-AQB62	A62B	Q63B Q52B		650
ERNT-AQB52	A52B	Q52B		505

5. Part Names and Installation Method

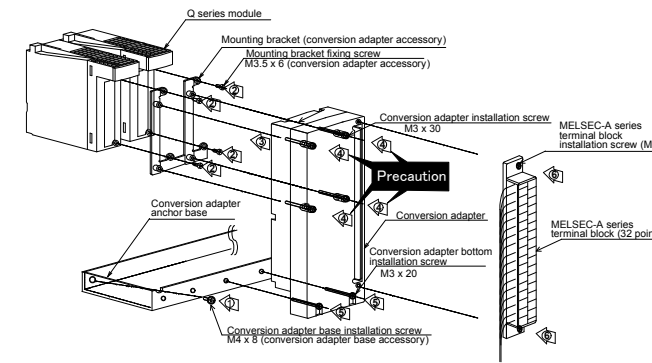

5.1 Installation Method

- Secure the conversion adapter anchor base to the base adapter or control panel using the conversion adapter anchor base installation screws (M4 x 8) provided as an accessory. (Two end locations)
 - Secure the mounting bracket to the Q series module using the mounting bracket fixing screws [M3.5 x 6 (conversion adapter accessory)]; two upper/lower locations.
 - Mount the conversion adapter onto the mounting bracket.
 - Secure the conversion adapter using the conversion adapter installation screws (M3 x 30; 4 locations).
- Precaution
- Before tightening the installation screws, check that the Conversion Adapter has been securely installed on the MELSEC-Q Series module. Tightening the screws in floating-off state or tilting state will damage the Conversion Adapter installation screws and the mounting bracket.
- Secure the conversion adapter using the conversion adapter bottom installation screw (M3 x 20; 2 location).
 - Secure the MELSEC-A series terminal block to the conversion adapter using the terminal block installation screws (M4; two upper/lower locations).

Product Warranty Details

Please confirm the following product warranty details prior to product use.

Gratis Warranty Terms and Gratis Warranty Range

If any fault or defect (hereinafter referred to as "Failure") attributable to Mitsubishi Electric Engineering Company Limited (hereinafter referred to as "MEE") should occur within the gratis warranty period, MEE shall repair the product free of charge via the distributor from whom you made your purchase.

■ Gratis Warranty Period

The gratis warranty period of this product shall be one (1) year from the date of purchase or delivery to the designated place. Note that after manufacture and shipment from MEE, the maximum distribution period shall be six (6) months, and the gratis warranty period after manufacturing shall be limited to eighteen (18) months. In addition, the gratis warranty period for repaired products shall not exceed the gratis warranty period established prior to repair.

■ Gratis Warranty Range

The gratis warranty range shall be limited to normal use based on the usage conditions, methods and environment, etc., defined by the terms and precautions, etc., given in the instruction manual, user's manual and caution labels on the product.

Warranty Period after Discontinuation of Production

- MEE shall offer product repair services (fee applied) for seven (7) years after production of the product has been discontinued. Discontinuation of production shall be reported via distributors.
- Product supply (including spare parts) is not possible after production has been discontinued.

Exclusion of Opportunity Loss and Secondary Loss from Warranty Liability

Regardless of the gratis warranty period, MEE shall not be liable for compensation for damages arising from causes not attributable to MEE, opportunity losses or lost profits incurred by the user due to Failures of MEE products, damages or secondary damages arising from special circumstances, whether foreseen or unforeseen by MEE, compensation for accidents, compensation for damages to products other than MEE products, or compensation for other work carried out by the user.

Changes in Product Specifications

The specifications given in the catalogs, manuals and technical documents are subject to change without notice.

This document is a new publication, effective April 2016. Specifications are subject to change without notice.